

## FEATURES

- Pre-leveled base
- Designed for tile-wall applications
- Slip-resistant, textured bottom
- Extended tiling flange (3T)
- Enhanced front profile
- Available in White only
- Patented design features:
  - corner drainage channels
  - step-design finishing guides
  - extended nailing flange
- Center drain
- Solid A<sup>2</sup> Composite material
- Durable high-gloss finish
- 15-year residential limited warranty

## PACKAGED DIMENSIONS (IN)

- 61 x 31 ¾ x 8 ½



## What is A<sup>2</sup> Composite?

Lightweight and durable, our A<sup>2</sup> Composite is an engineered compound of resin, glass and special fillers formed into sheets. These sheets are then placed under high pressure and heat to liquify the compound, allowing it to flow and take the shape of almost any form imaginable. The results are simple, stylish and a snap to install.





# 6030CPANNS

60 x 30 x 6  
inches

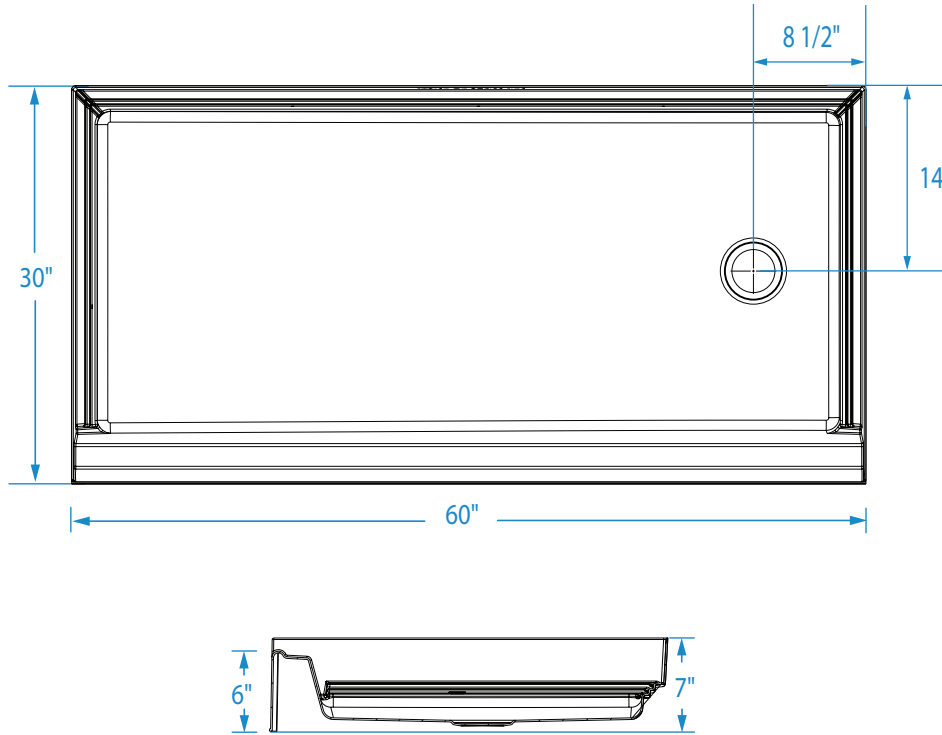

### FEATURES

Dimensional Tolerance  $\pm \frac{3}{16}$ ". Dimensions needed for site preparation should be measured from the unit. Manufacturer assumes no responsibility for preparatory work.

Model #	Material	Drain	Net Wt. lbs	Pkg. Wt. lbs
Shower Pan #6030CPANNS	A <sup>2</sup> Composite	LH or RH	47	52

### DIMENSIONS

Specifications	inches
Width: Overall / Net	60
Depth: Overall / Net	30
Height: Overall / Net	7 / 6
Enclosure Opening	-
Skirt Height	6
Drain Rough-In (from Back Wall)	14
Drain Rough-In (from Side Wall)	8 1/2
Drain: Diameter / Clearance	3 1/4 / $\emptyset$

### FRAMING DIMENSIONS inches

Type	D Depth	W Width	H Height	A	B	C
Alcove	30	60	-	Box Out	8 1/2	14

