

FEATURES

- Pre-Leveled base
- Slip resistant, textured bottom
- Available in White only
- Left, right drain
- Durable high gloss finish
- 15-year residential limited warranty

OPTIONS

- Coordinating wall sets available
*See A² price list for tub-shower assembly and/or wall set part numbers

PACKAGED DIMENSIONS (IN)

- 62 1/2 x 34 x 17 3/4



WHAT IS A² COMPOSITE?

Lightweight and durable, our A² Composite is an engineered compound of resin, glass and special fillers formed into sheets. These sheets are then placed under high pressure and heat to liquify the compound, allowing it to flow and take the shape of almost any form imaginable. The results are simple, stylish and a snap to install.





6030CTMIN

60 x 30 x 15 inches

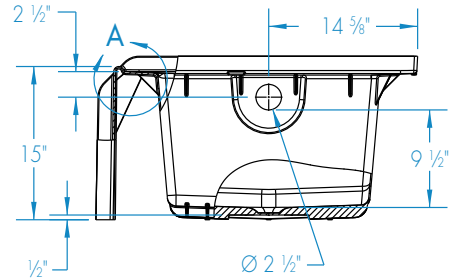
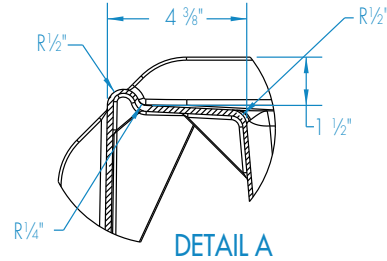
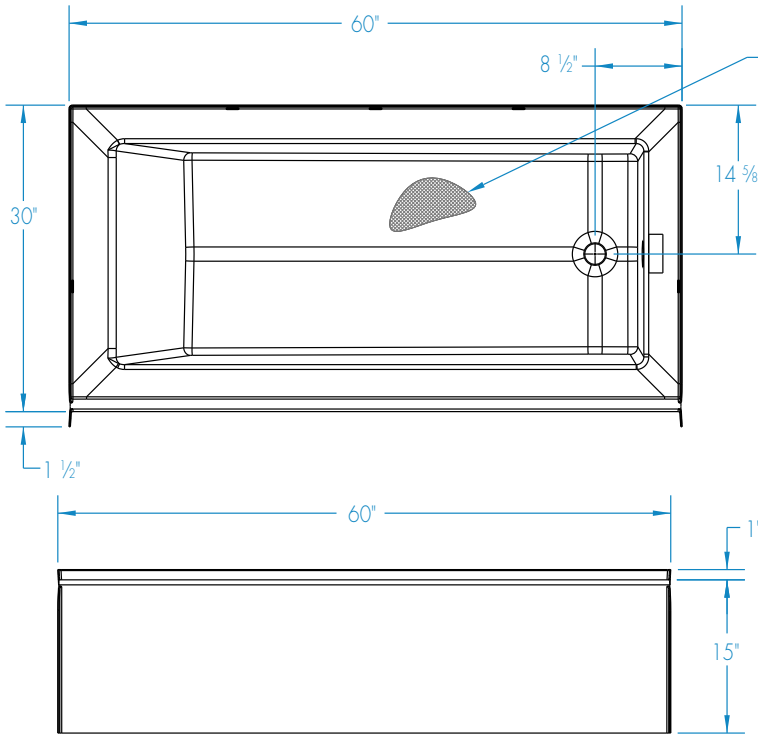

FEATURES

Dimensional Tolerance $\pm \frac{3}{16}$ ". Dimensions needed for site preparation should be measured from the unit. Manufacturer assumes no responsibility for preparatory work.

| Model # | Material | Jets | Motor | Controls | Drain | Net Wt. lbs | Pkg. Wt. lbs |
|-------------------|--------------------------|------|-------|----------|----------|-------------|--------------|
| Soaker #6030CTMIN | A ² Composite | - | - | - | LH or RH | 57 | 65 |

DIMENSIONS

| Specifications | inches |
|---------------------------------|-------------|
| Width: Overall / Net | 60 |
| Depth: Overall / Net | 31 1/2 / 30 |
| Height: Overall / Net | 16 / 15 |
| Enclosure Opening | - |
| Skirt Height | 15 |
| Drain Rough-In (from Back Wall) | 14 5/8 |
| Drain Rough-In (from Side Wall) | 2 3/4 |
| Drain: Diameter / Clearance | 2 / 1/2 |

FRAMING DIMENSIONS inches

| Type | D Depth | W Width | H Height | A | B | C |
|--------|---------|---------|----------|---------|-------|--------|
| Alcove | 31 1/2 | 60 | 16 | Box Out | 2 3/4 | 14 5/8 |

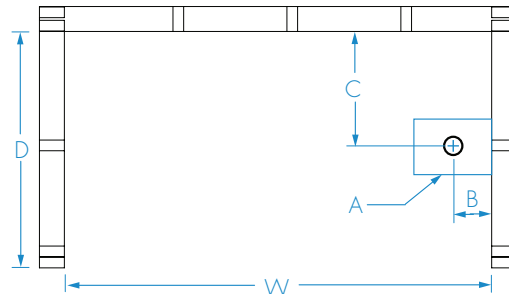

SUMP DATA

| Top of Drain to Bottom of Overflow | Capacity to Overflow gal | Min. Operating Capacity gal | WIDTH @ centerline | | DEPTH @ centerline | |
|------------------------------------|--------------------------|-----------------------------|--------------------|--------|--------------------|--------|
| | | | Top | Bottom | Top | Bottom |
| 9 1/2 | 36 1/10 | - | 51 5/8 | 44 1/2 | 21 5/8 | 19 5/8 |