

## FEATURES

- Above Floor Rough (AFR)
- Pre-Leveled base
- Slip resistant, textured bottom
- Available in White only
- Left, right drain
- Durable high gloss finish
- 15-year residential limited warranty

## OPTIONS

- Coordinating wall sets available  
\*See A<sup>2</sup> price list for tub-shower assembly and/or wall set part numbers

## PACKAGED DIMENSIONS (IN)

- 63 x 36 ½ x 24 ½



## WHAT IS A<sup>2</sup> COMPOSITE?

Lightweight and durable, our A<sup>2</sup> Composite is an engineered compound of resin, glass and special fillers formed into sheets. These sheets are then placed under high pressure and heat to liquify the compound, allowing it to flow and take the shape of almost any form imaginable. The results are simple, stylish and a snap to install.





### 6032CTMM

60 x 32 x 21  
inches

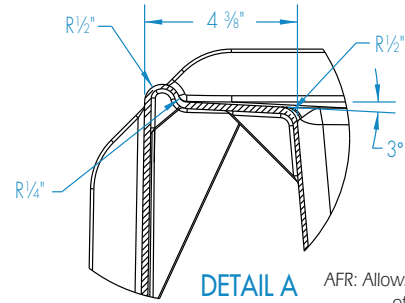
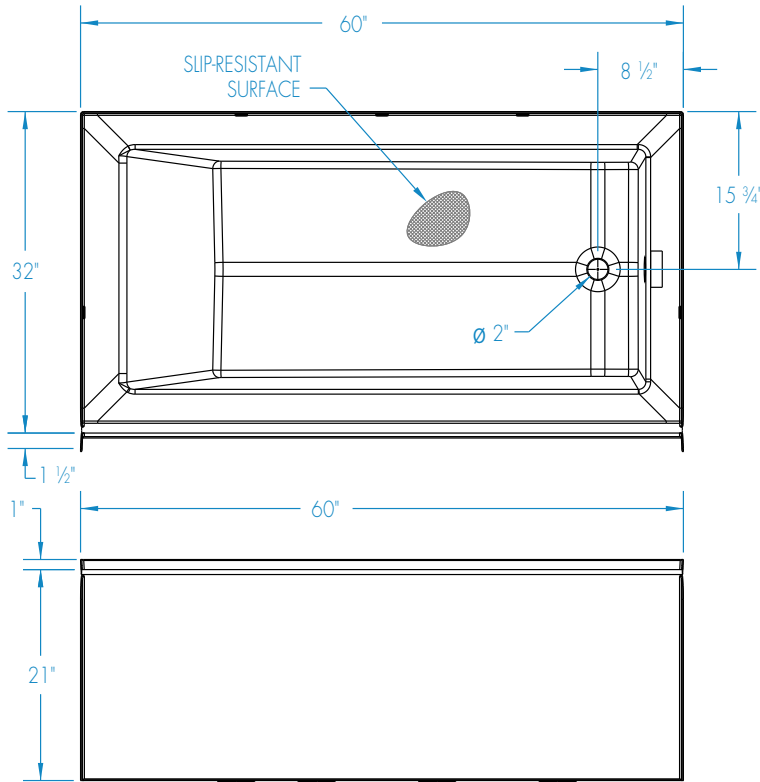

AFR: Allows for above the floor installation of waste, overflow and drainage.

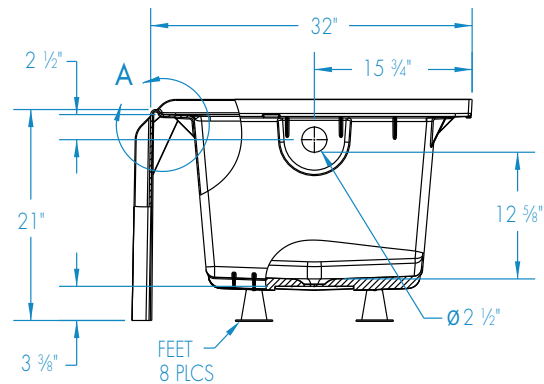

### FEATURES

Dimensional Tolerance  $\pm 3/8$ ". Dimensions needed for site preparation should be measured from the unit. Manufacturer assumes no responsibility for preparatory work.

Model #	Material	Jets	Motor	Controls	Drain	Net Wt. lbs.	Pkg. Wt. lbs.
AFR Soaker #6032CTMM	A2 Composite	-	-	-	LH or RH	67	75

### DIMENSIONS

Specifications	inches
Width: Overall / Net	60
Depth: Overall / Net	33 1/2 / 32
Height: Overall / Net	22 / 18
Enclosure Opening	-
Skirt Height	21
Drain Rough-In (from Back Wall)	15 3/4
Drain Rough-In (from Side Wall)	2 3/4
Drain: Diameter / Clearance	2 / 3 1/2

### FRAMING DIMENSIONS INCHES

Type	D Depth	W Width	H Height	A	B	C
Alcove	33 1/2	60	22	Box Out	2 3/4	15 3/4

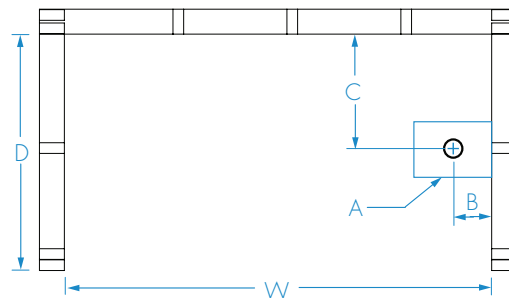

### SUMP DATA

Top of Drain to Bottom of Overflow	Capacity to Overflow gal	Min. Operating Capacity gal	WIDTH @ centerline		DEPTH @ centerline	
			Top	Bottom	Top	Bottom
12 5/8	52 3/10	-	51 5/8	42 1/8	23 3/8	21 3/8