

Service Manual

Super Quiet Ventilating Fan/Light Combination

WhisperLite™
(North American Market)

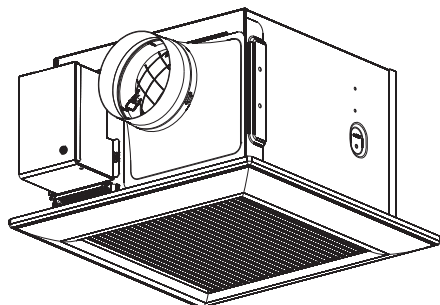

FV-05VQ5
FV-08VQ5
FV-11VQ5

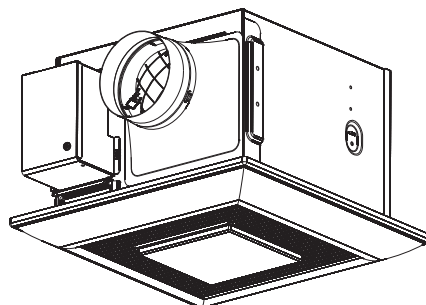

FV-08VQL5
FV-11VQL5

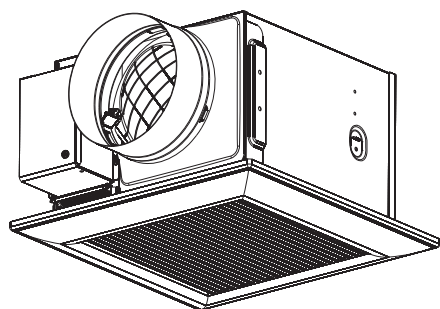

FV-15VQ5

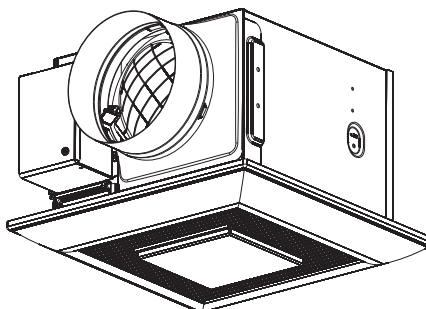

FV-15VQL5



WARNING

This service information is designed for experienced repair technicians only and is not designed for use by the general public. It does not contain warnings or cautions to advise non-technical individuals of potential dangers in attempting to service a product. Products powered by electricity should be serviced or repaired only by experienced professional technicians. Any attempt to service or repair the product or products dealt with in this service information by anyone else could result in serious injury or death.

IMPORTANT SAFETY NOTICE

There are special components used in this equipment which are important for safety. These parts are marked by  in the Schematic Diagrams, Exploded Views and Replacement Parts List. It is essential that these critical parts should be replaced with manufacturer's specified parts to prevent shock, fire or other hazards. Do not modify the original design without permission of manufacture. We suggest to handle such parts after the static electricity prevention. It is forbidden to touch the PCB parts by bare hands during the repairing process.

CONTENTS

	PAGE
1 Specifications	1
2 Parts Identification	2~5
3 Wiring Diagram	6
4 Parts List	7~10

1. Specifications

FV-05VQ5 FV-11VQ5 FV-08VQ5 FV-15VQ5

Model No.	Air direction	Voltage (V)	Frequency (Hz)	Duct diameter (inches)	Noise (sones)	Power consumption (W)	Speed (rpm)	Air volume at 0.1"WG (CFM)	Weight lb.(kg)
FV-05VQ5	Exhaust	120	60	4	<0.3	11.0	730	50	9.9 (4.5)
FV-08VQ5	Exhaust	120	60	4	<0.3	14.5	815	80	9.9 (4.5)
FV-11VQ5	Exhaust	120	60	4	<0.3	22.0	960	110	9.9 (4.5)
FV-15VQ5	Exhaust	120	60	6	<0.3	28.5	700	150	11.2 (5.1)

HVI Certified performance based on HVI Procedures 915,916,and 920.

FV-08VQL5 FV-11VQL5 FV-15VQL5

Model No.	Air direction	Voltage (V)	Frequency (Hz)	Duct diameter (inches)	Noise (sones)	Power consumption(W)			Speed (rpm)	Air volume at 0.1"WG (CFM)	Weight lb.(kg)
						Fan	Lighting unit				
							Fluorescent lamp	Night lamp			
FV-08VQL5	Exhaust	120	60	4	<0.3	14.5	32	4	890	80	11.0 (5.0)
FV-11VQL5	Exhaust	120	60	4	0.5	23.5	32	4	1065	110	11.0 (5.0)
FV-15VQL5	Exhaust	120	60	6	0.9	32.0	32	4	805	150	12.3 (5.6)

HVI Certified performance based on HVI Procedures 915,916,and 920.

1. Parts Identification

FV-05VQ5

FV-08VQ5

FV-11VQ5

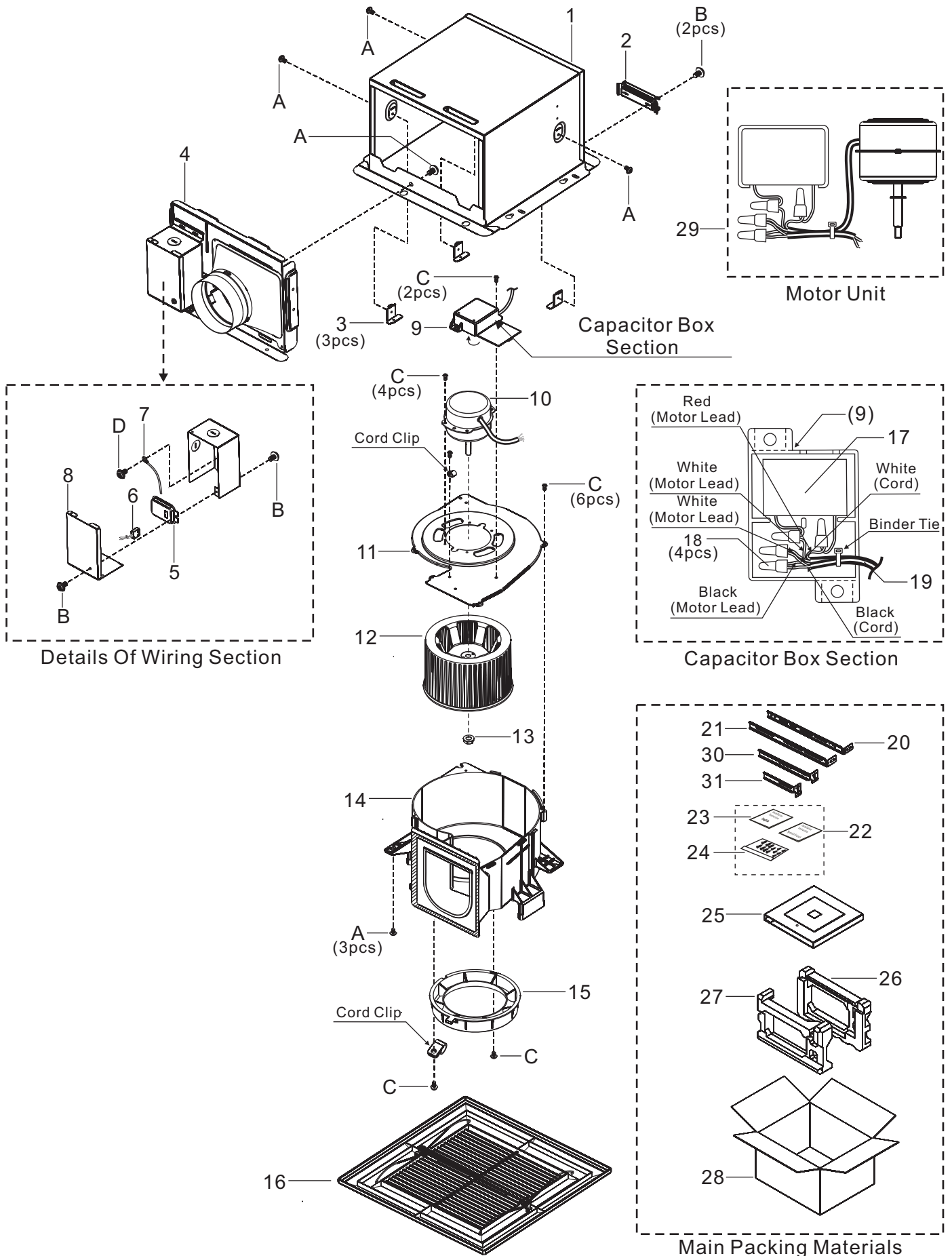

1. Parts Identification

FV-08VQL5
FV-11VQL5

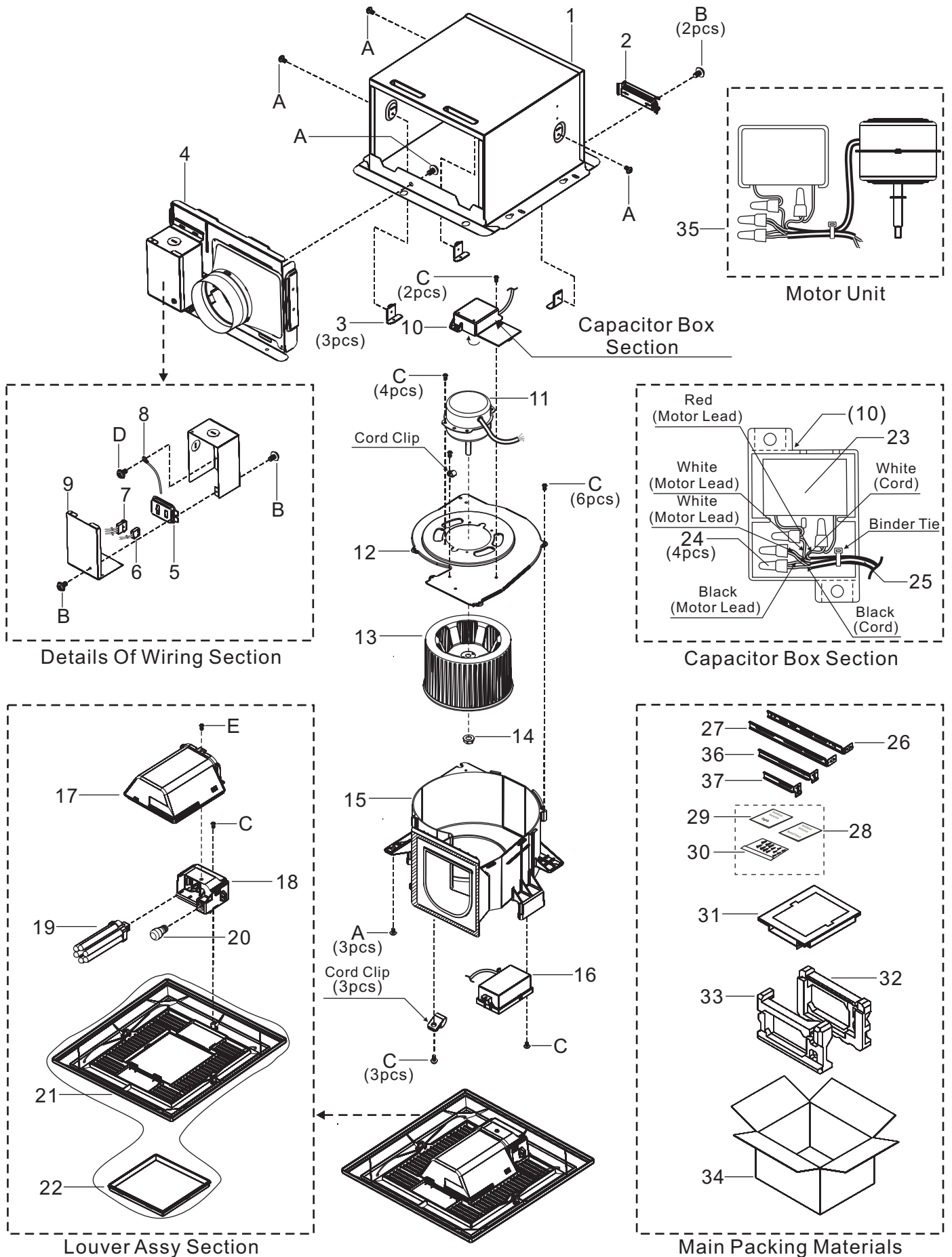

1. Parts Identification

FV-15VQ5

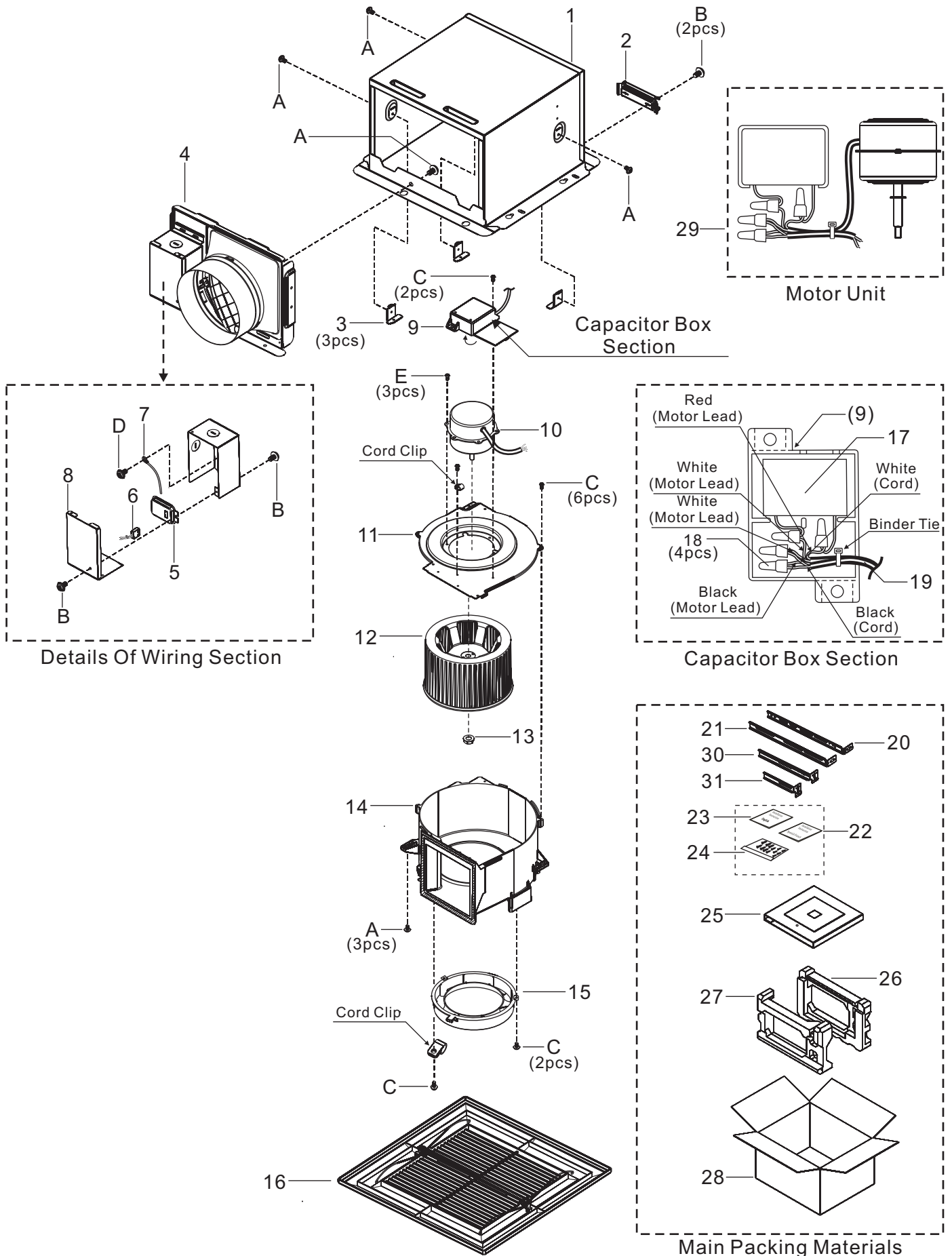

1. Parts Identification

FV-15VQL5

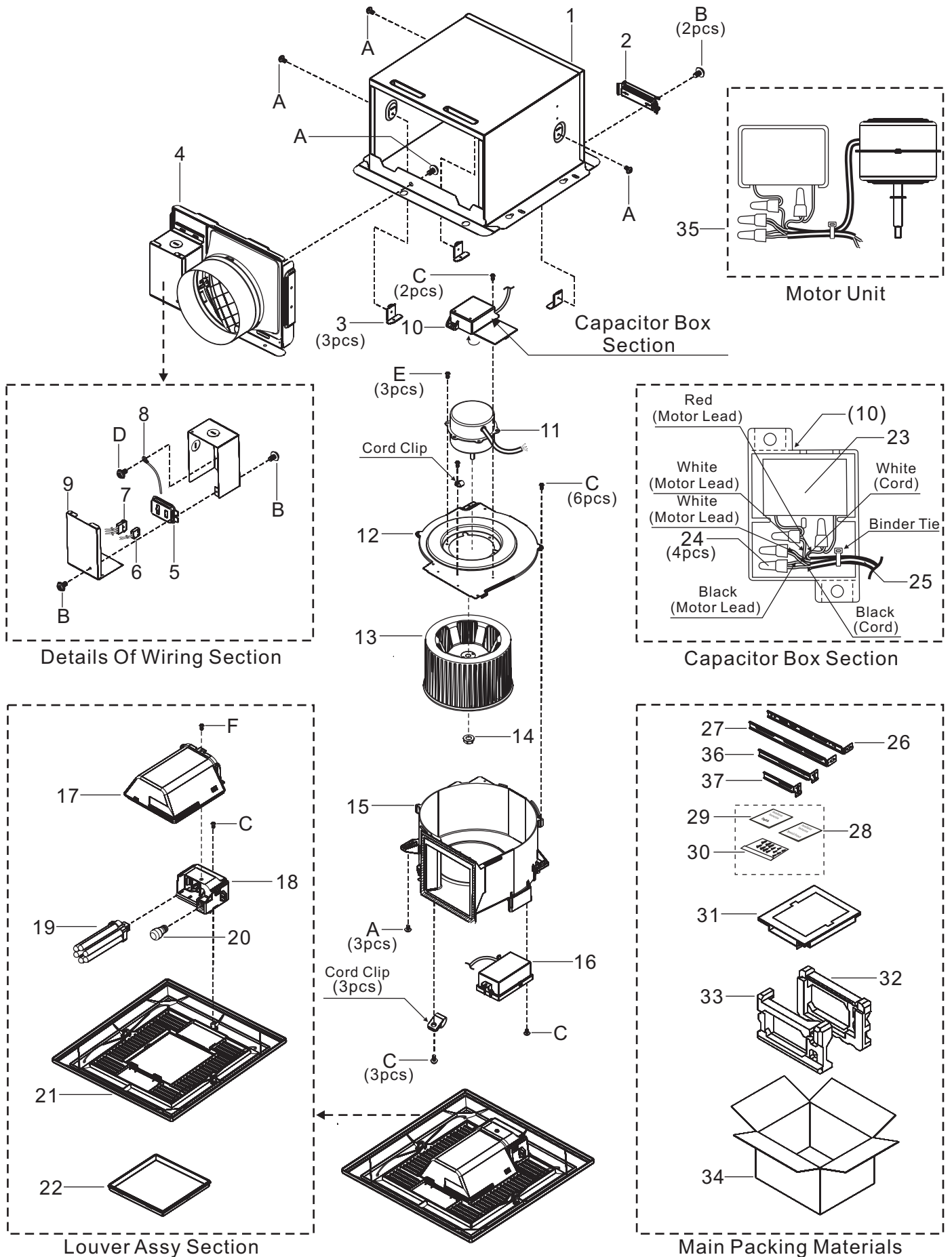

2. Wiring Diagram

FV-05VQ5 FV-11VQ5
FV-08VQ5 FV-15VQ5

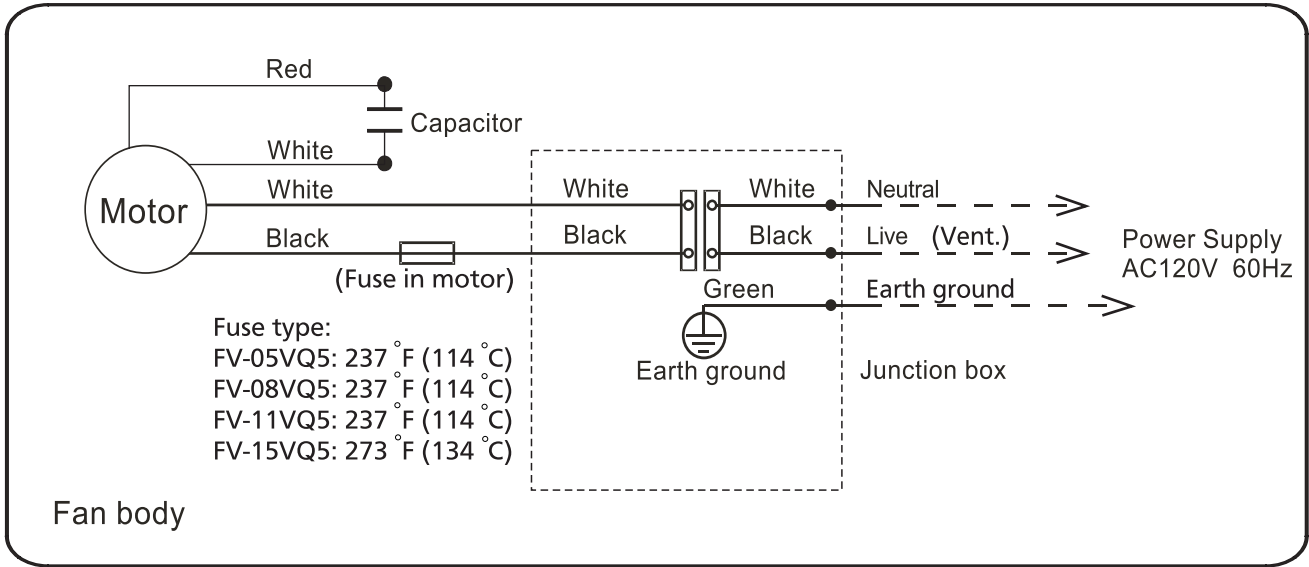

FV-08VQL5 FV-11VQL5
FV-15VQL5

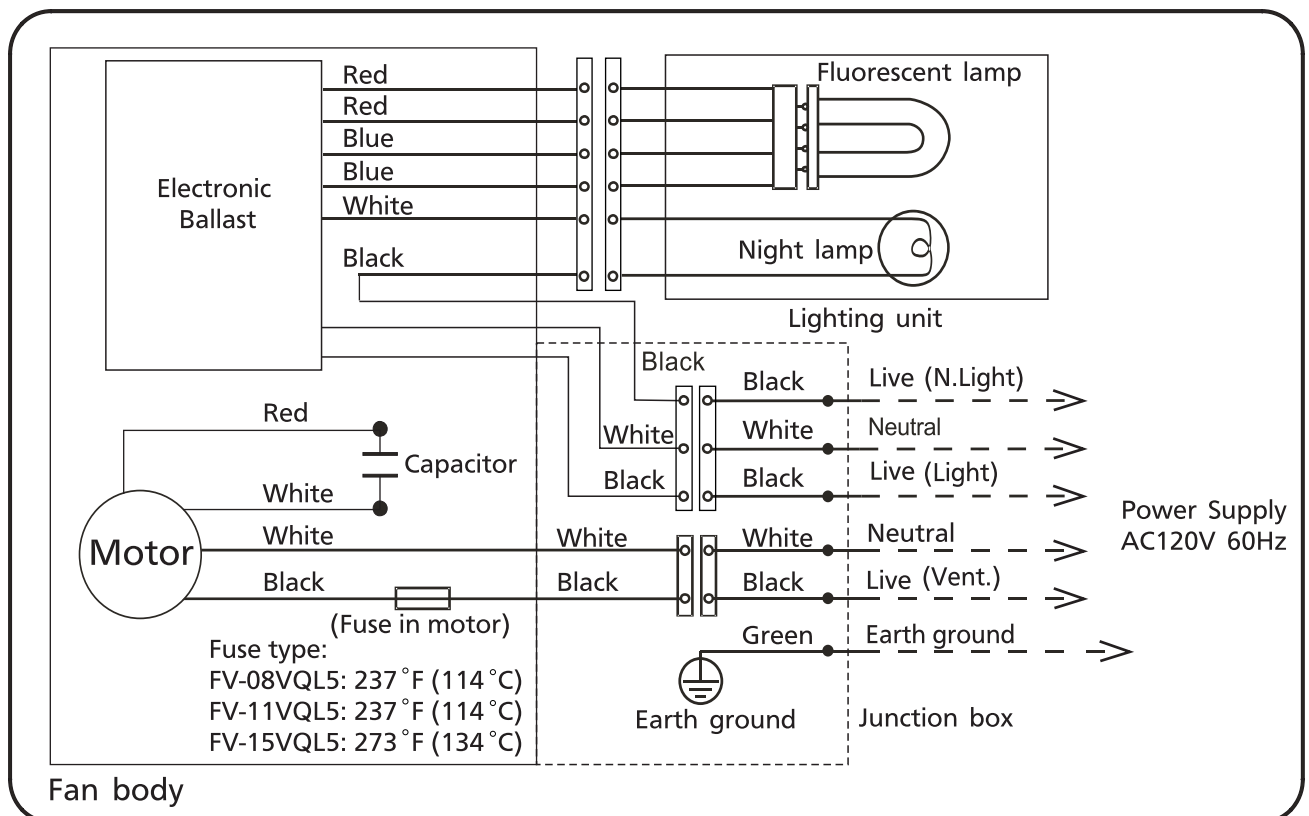

3. Parts List

FV-05VQ5

FV-08VQ5

FV-11VQ5

No.	Part No.	Part Name	Q'ty	Remark
1	FFV1600111S	Frame Assembly	1	
2	FFV0420027S	Bracket Cover	1	
3	FFV0800001S	Casing Support	3	
4	FFV0000107S	Adapter Assembly	1	Include One Bracket Cover&Two Screw
5	FFV0900046S	Connector Plate	1	
6	FFV0900038S	Connector Assembly V	1	⚠
7	FFV3402103S	Earth Lead Wire	1	⚠
8	FFV2800012S	Junction Box Cover	1	
9	FFV0760028S	Capacitor Box	1	⚠
10	FFV3702213S	Motor Assembly	1	⚠
(10)	FFV3702214S	Motor Assembly	1	⚠
(10)	FFV3702215S	Motor Assembly	1	⚠
11	FFV3730086S	Motor Support	1	
12	FFV0400103S	Blade	1	
13	FFV7020021S	Nut	1	For Fixing Blade
14	FFV0790077S	Casing	1	
15	FFV4300131S	Orifice	1	
16	FFV3402124S	Louver Section	1	
17	FFV0750203S	Capacitor	1	AC250V 1.1uF,For FV-05/08VQ5 ⚠
(17)	FFV0750204S	Capacitor	1	AC250V 1.6uF,For FV-11VQ5 ⚠
18	FFV0900024S	Connector	4	⚠
19	FFV0730031S	Cord	1	⚠
20	FFV5710023S	Suspension Bracket 2	1	
21	FFV5710024S	Suspension Bracket 1	1	
22	FFV2540104S	Installation Instruction	1	For USA Market
(22)	FFV2540105S	Installation Instruction	1	For CA Market
23	FFV2540106S	Instruction	1	
24	FFV0010200S	Accessory A	1	
25	FFV4710210S	Louver Pad Assembly	1	
26	FFV4710322S	Right Pad	1	
27	FFV4710323S	Left Pad	1	
28	FFV9000951S	Packing Case Assembly	1	For FV-05VQ5
(28)	FFV9000952S	Packing Case Assembly	1	For FV-08VQ5
(28)	FFV9000953S	Packing Case Assembly	1	For FV-11VQ5
29	FFV3702218S	Motor Unit	1	For FV-05VQ5 ⚠
(29)	FFV3702219S	Motor Unit	1	For-FV-08VQ5 ⚠
(29)	FFV3702220S	Motor Unit	1	For-FV-11VQ5 ⚠
30	FFV5710018S	Suspension Bracket 2	1	
31	FFV5710019S	Suspension Bracket 1	1	
A	FFV7000065S	Bind Screw	8	
B	FFV7000108S	Truss Tap Screw	4	
C	FFV7000089S	Truss Tap Screw	14	
D	FFV7000168S	Screw Assembly	1	Include Spring Washer&P.R Washer

3. Parts List

FV-08VQL5

FV-11VQL5

No.	Part No.	Part Name	Q'ty	Remark
1	FFV1600111S	Frame Assembly	1	
2	FFV0420027S	Bracket Cover	1	
3	FFV0800001S	Casing Support	3	
4	FFV0000109S	Adapter Assembly	1	Include One Bracket Cover&Two Screw
5	FFV0900047S	Connector Plate	1	
6	FFV0900038S	Connector Assembly V	1	⚠
7	FFV0900039S	Connector Assembly L	1	⚠
8	FFV3402103S	Earth Lead Wire	1	⚠
9	FFV2800012S	Junction Box Cover	1	
10	FFV0760028S	Capacitor Box	1	⚠
11	FFV3702217S	Motor Assembly	1	⚠
(11)	FFV3702215S	Motor Assembly	1	⚠
12	FFV3730086S	Motor Support	1	
13	FFV0400103S	Blade	1	
14	FFV7020021S	Nut	1	For Fixing Blade
15	FFV0790077S	Casing	1	
16	FFV3470003S	Ballast Assembly	1	⚠
17	FFV3420025S	Light Cover Assembly	1	⚠
18	FFV3420026S	Lamp Holder Section	1	⚠
19	FFV3420027S	Fluorescent Lamp	1	⚠
20	FFV3420005S	Night Lamp	1	⚠
21	FFV3420028S	Louver Section	1	Include Lamp Cover ⚠
22	FFV3420029S	Lamp Cover	1	
23	FFV0750203S	Capacitor	1	AC250V 1.1uF,For FV-08VQ5 ⚠
(23)	FFV0750204S	Capacitor	1	AC250V 1.6uF,For FV-11VQ5 ⚠
24	FFV0900024S	Connector	4	⚠
25	FFV0730031S	Cord	1	⚠
26	FFV5710023S	Suspension Bracket 2	2	
27	FFV5710024S	Suspension Bracket 1	2	
28	FFV2540107S	Installation Instruction	1	For USA Market
(28)	FFV2540108S	Installation Instruction	1	For CA Market
29	FFV2540109S	Instruction	1	
30	FFV0010200S	Accessory A	1	
31	FFV4710324S	Louver Case Assembly	1	
32	FFV4710322S	Right Pad	1	
33	FFV4710323S	Left Pad	1	
34	FFV9000955S	Packing Case Assembly	1	For FV-08VQ5
(34)	FFV9000956S	Packing Case Assembly	1	For FV-11VQ5
35	FFV3702221S	Motor Unit	1	For FV-08VQL5 ⚠
(35)	FFV3702220S	Motor Unit	1	For-FV-11VQL5 ⚠
36	FFV5710018S	Suspension Bracket 2	1	
37	FFV5710019S	Suspension Bracket 1	1	
A	FFV7000065S	Bind Screw	8	
B	FFV7000108S	Truss Tap Screw	4	
C	FFV7000089S	Truss Tap Screw	17	
D	FFV7000168S	Screw Assembly	1	Include Spring Washer&P.R Washer
E	FFV7000191S	Bind Screw	1	For Fixing Light Cover

3. Parts List

FV-15VQ5

No.	Part No.	Part Name	Q'ty	Remark
1	FFV1600111S	Frame Assembly	1	
2	FFV0420027S	Bracket Cover	1	
3	FFV0800001S	Casing Support	3	
4	FFV0000108S	Adapter Assembly	1	Include One Bracket Cover&Two Screw
5	FFV0900046S	Connector Plate	1	
6	FFV0900038S	Connector Assembly V	1	⚠
7	FFV3402103S	Earth Lead Wire	1	⚠
8	FFV2800012S	Junction Box Cover	1	
9	FFV0760028S	Capacitor Box	1	⚠
10	FFV3702216S	Motor Assembly	1	⚠
11	FFV3730087S	Motor Support	1	
12	FFV0400104S	Blade	1	
13	FFV7020021S	Nut	1	For Fixing Blade
14	FFV0790078S	Casing	1	
15	FFV4300132S	Orifice	1	
16	FFV3402124S	Louver Section	1	
17	FFV0750107S	Capacitor	1	AC250V 3.0uF ⚠
18	FFV0900024S	Connector	4	⚠
19	FFV0730031S	Cord	1	⚠
20	FFV5710023S	Suspension Bracket 2	2	
21	FFV5710024S	Suspension Bracket 1	2	
22	FFV2540104S	Installation Instruction	1	For USA Market
(22)	FFV2540105S	Installation Instruction	1	For CA Market
23	FFV2540106S	Instruction	1	
24	FFV0010200S	Accessory A	1	
25	FFV4710210S	Louver Pad Assembly	1	
26	FFV4710322S	Right Pad	1	
27	FFV4710323S	Left Pad	1	
28	FFV9000954S	Packing Case Assembly	1	
29	FFV3702222S	Motor Unit	1	⚠
30	FFV5710018S	Suspension Bracket 2	1	
31	FFV5710019S	Suspension Bracket 1	1	
A	FFV7000065S	Bind Screw	8	
B	FFV7000108S	Truss Tap Screw	4	
C	FFV7000089S	Truss Tap Screw	10	
D	FFV7000168S	Screw Assembly	1	Include Spring Washer&P.R Washer
E	FFV7000079S	Pan Tap Screw	3	For Fixing Motor Assembly

3. Parts List

FV-15VQL5

No.	Part No.	Part Name	Q'ty	Remark
1	FFV1600111S	Frame Assembly	1	
2	FFV0420027S	Bracket Cover	1	
3	FFV0800001S	Casing Support	3	
4	FFV0000110S	Adapter Assembly	1	Include One Bracket Cover&Two Screw
5	FFV0900047S	Connector Plate	1	
6	FFV0900038S	Connector Assembly V	1	⚠
7	FFV0900039S	Connector Assembly L	1	⚠
8	FFV3402103S	Earth Lead Wire	1	⚠
9	FFV2800012S	Junction Box Cover	1	
10	FFV0760028S	Capacitor Box	1	⚠
11	FFV3702216S	Motor Assembly	1	⚠
12	FFV3730087S	Motor Support	1	
13	FFV0400104S	Blade	1	
14	FFV7020021S	Nut	1	For Fixing Blade
15	FFV0790078S	Casing	1	
16	FFV3470003S	Ballast Assembly	1	⚠
17	FFV3420025S	Light Cover Assembly	1	⚠
18	FFV3420026S	Lamp Holder Section	1	⚠
19	FFV3420027S	Fluorescent Lamp	1	⚠
20	FFV3420005S	Night Lamp	1	⚠
21	FFV3420028S	Louver Section	1	Include Lamp Cover ⚠
22	FFV3420029S	Lamp Cover	1	
23	FFV0750129S	Capacitor	1	AC250V 3.5uF ⚠
24	FFV0900024S	Connector	4	⚠
25	FFV0730031S	Cord	1	⚠
26	FFV5710023S	Suspension Bracket 2	2	
27	FFV5710024S	Suspension Bracket 1	2	
28	FFV2540107S	Installation Instruction	1	For USA Market
(28)	FFV2540108S	Installation Instruction	1	For CA Market
29	FFV2540109S	Instruction	1	
30	FFV0010200S	Accessory A	1	
31	FFV4710324S	Louver Case Assembly	1	
32	FFV4710322S	Right Pad	1	
33	FFV4710323S	Left Pad	1	
34	FFV9000957S	Packing Case Assembly	1	
35	FFV3702222S	Motor Unit	1	⚠
36	FFV5710018S	Suspension Bracket 2	1	
37	FFV5710019S	Suspension Bracket 1	1	
A	FFV7000065S	Bind Screw	8	
B	FFV7000108S	Truss Tap Screw	4	
C	FFV7000089S	Truss Tap Screw	13	
D	FFV7000168S	Screw Assembly	1	Include Spring Washer&P.R Washer
E	FFV7000079S	Pan Tap Screw	3	For Fixing Motor Assembly
F	FFV7000191S	Bind Screw	1	For Fixing Light Cover