

Service Manual

Ventilating Fan
Whisper Warm™
(North America Market)

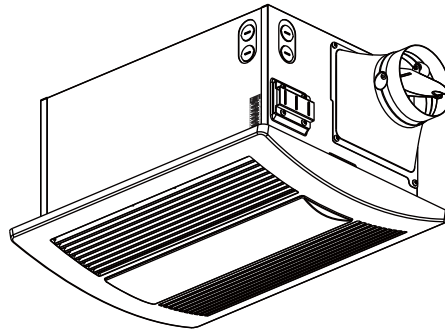

FV-11VHL2

SPECIFICATIONS

Model No.	Air direction	Voltage (V)	Frequency (Hz)	Power consumption (W)				Speed (rpm)		Air deliver		Noise (sone)	Weight lb. (kg)
				Heat	Vent	Fluorescent lamp	Night lamp	Heat	Vent	Vent (0.1" WG) (cfm)			
FV-11VHL2	Exhaust & Circulation	120	60	1425	29.5	13X2	4	1540	720	110	0.7	17.8 (8.1)	

Specifications of Vent are based on HVI standard.

⚠ WARNING

This service information is designed for experienced repair technicians only and is not designed for use by the general public. It does not contain warnings or cautions to advise non-technical individuals of potential dangers in attempting to service a product. Products powered by electricity should be serviced or repaired only by experienced professional technicians. Any attempt to service or repair the product or products dealt with in this service information by anyone else could result in serious injury or death.

IMPORTANT SAFETY NOTICE

There are special components used in this equipment which are important for safety. These parts are marked by \triangle in the Schematic Diagrams, Exploded Views and Replacement Parts List. It is essential that these critical parts should be replaced with manufacturer's specified parts to prevent shock, fire or other hazards. Do not modify the original design without permission of manufacture.

We suggest to handle such parts after the static electricity prevention.

It is forbidden to touch the PCB parts by bare hands during the repairing process.

CONTENTS

	PAGE
1. Parts Identification	1~7
2. Wiring Diagram	8
3. Parts List	9~12

1. Parts Identification

FV-11VHL2

Main Body Section

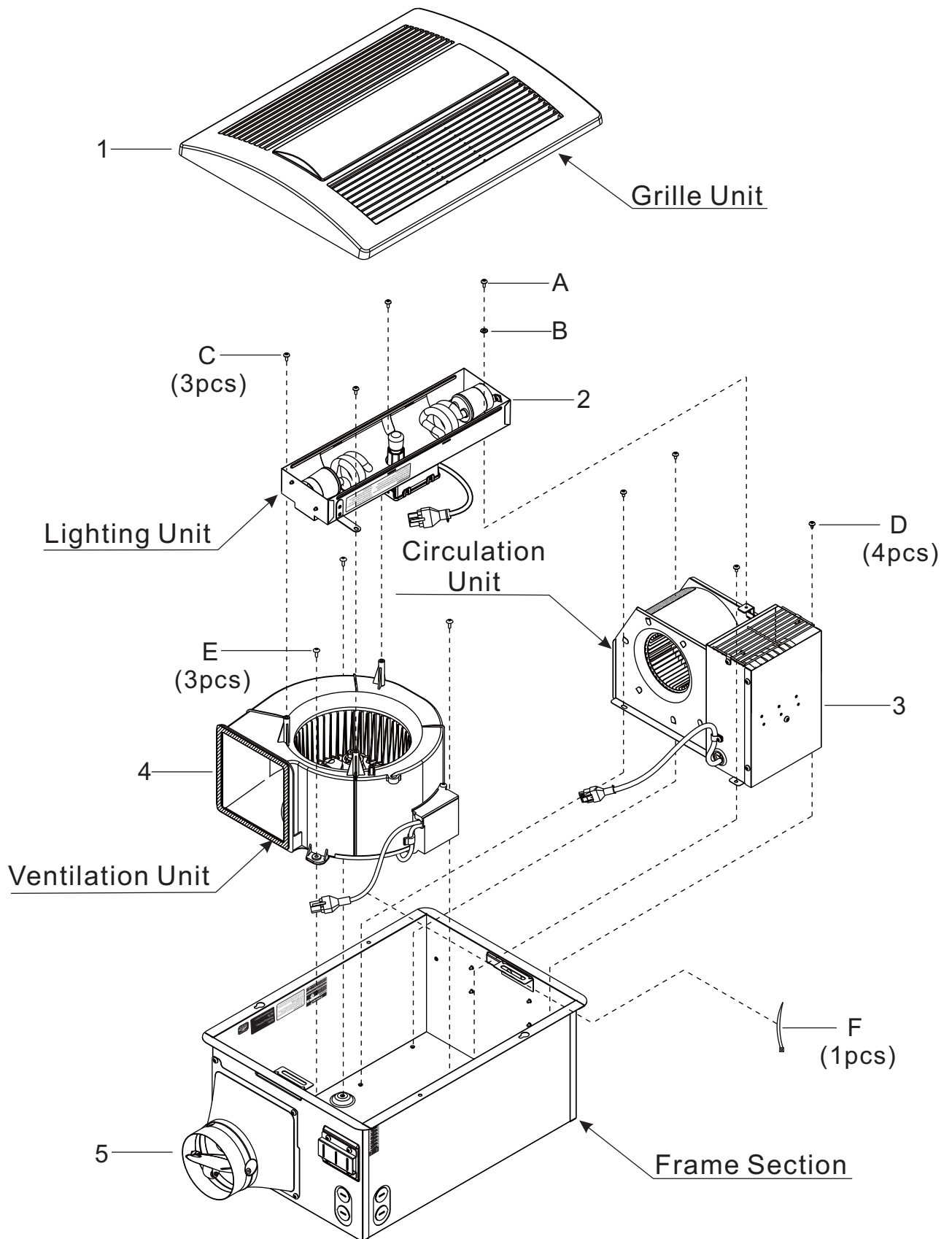

1. Parts Identification

FV-11VHL2

Frame Unit

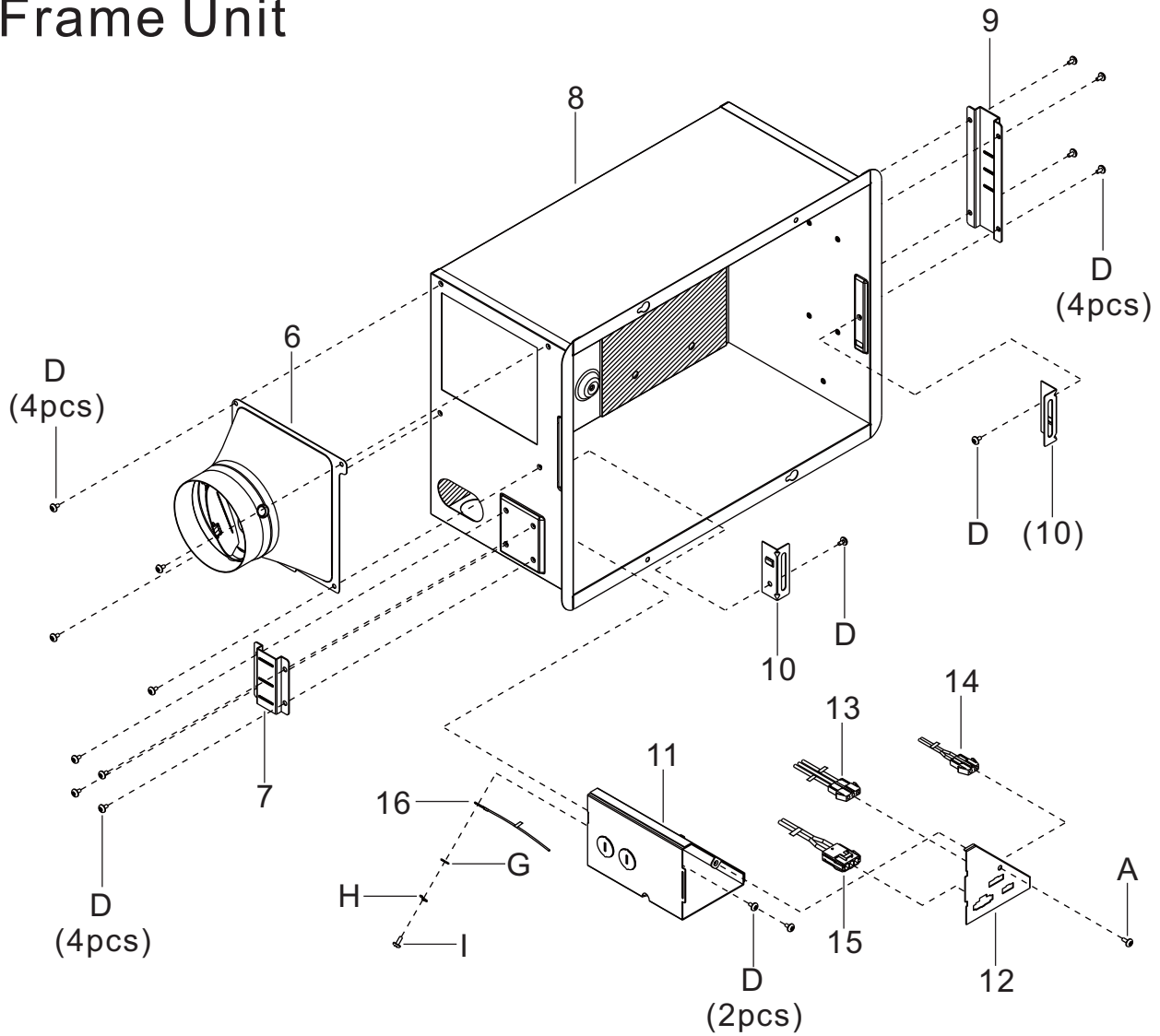

Lighting Unit

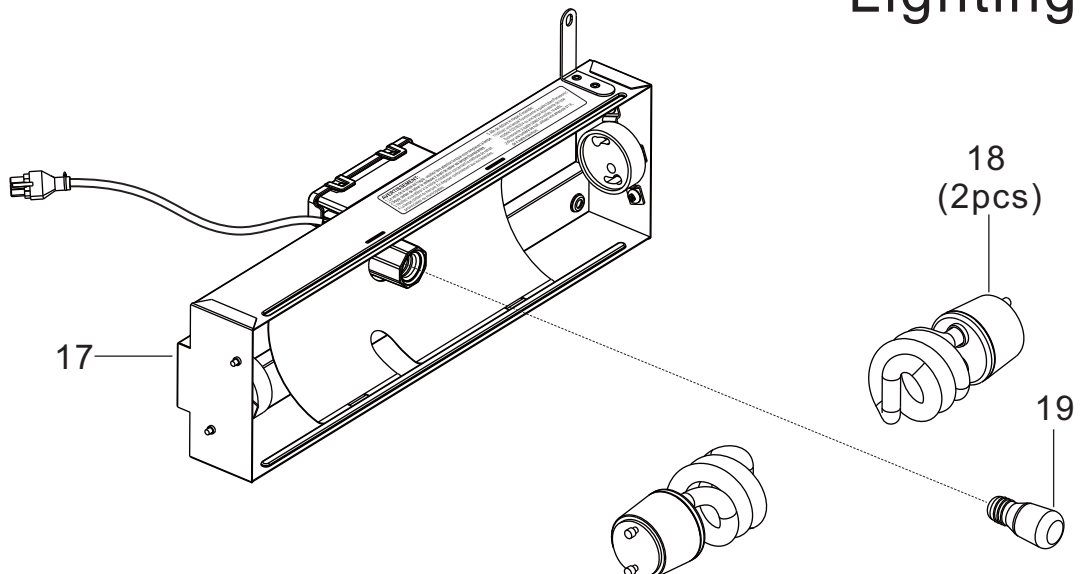

1. Parts Identification

FV-11VHL2

Circulation Unit

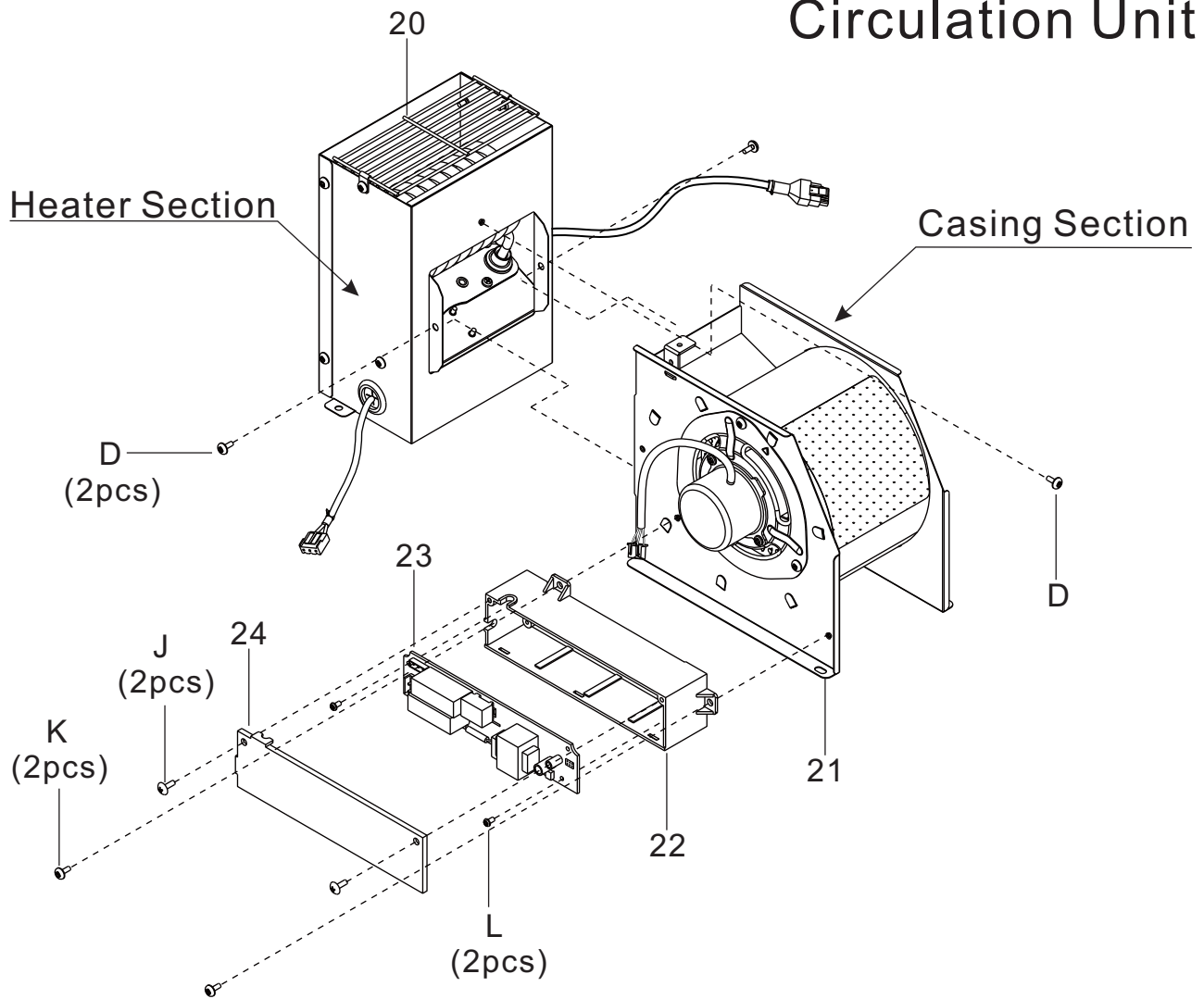

Grille Unit

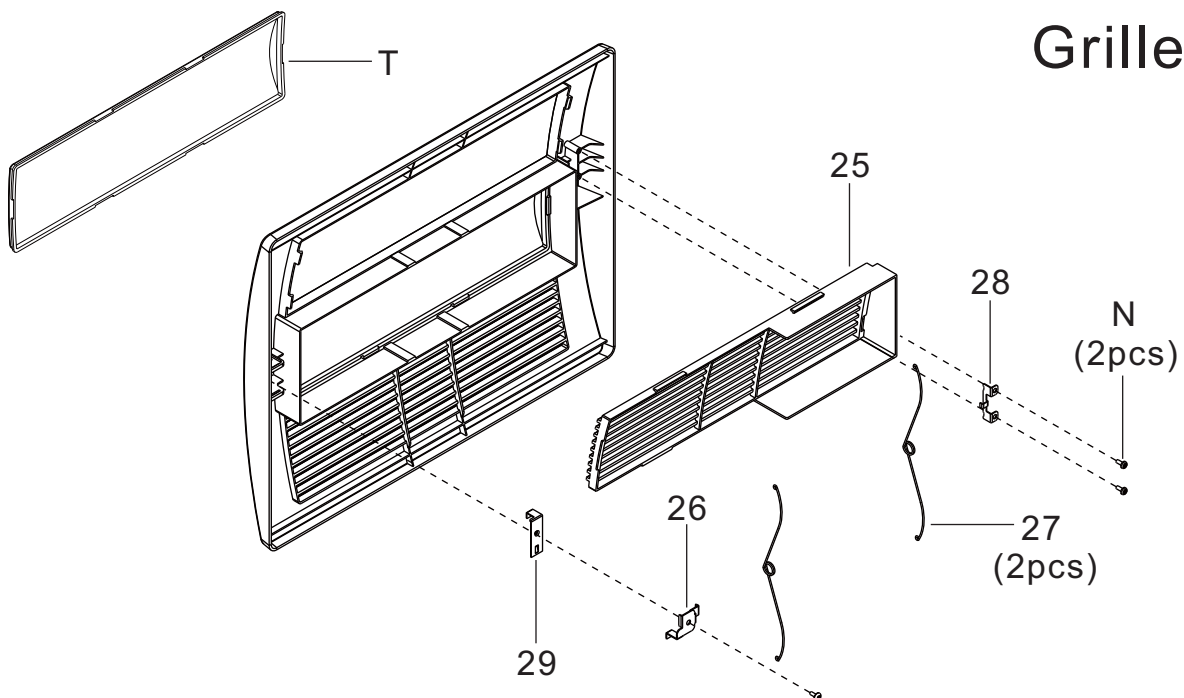

1. Parts Identification

FV-11VHL2

Casing Section

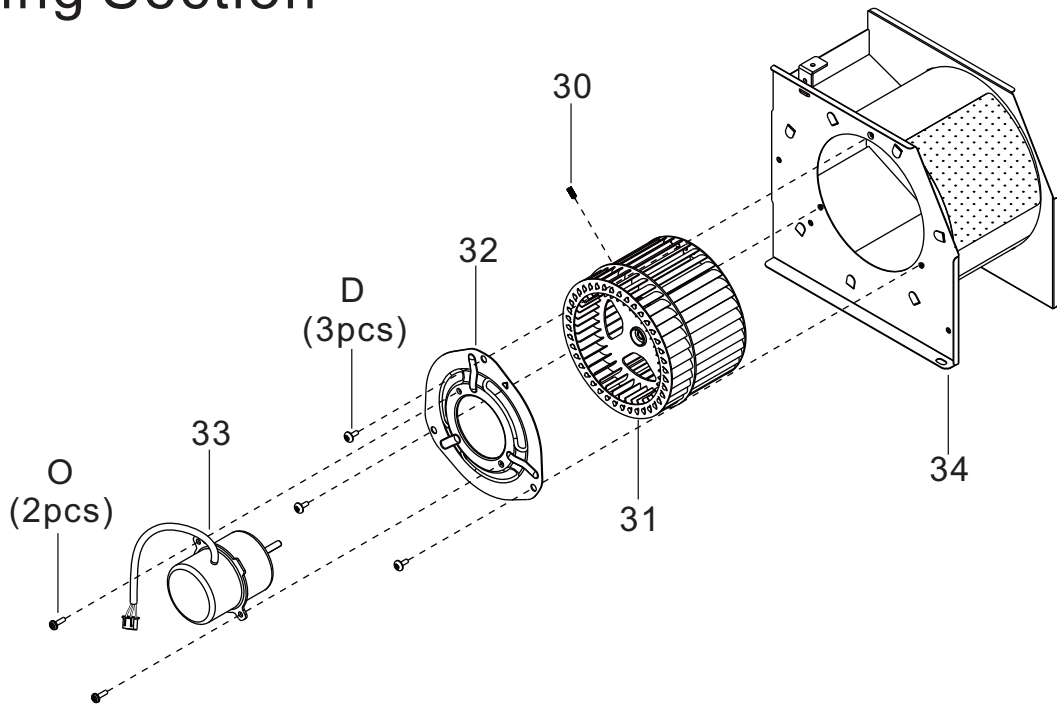

Heater Section

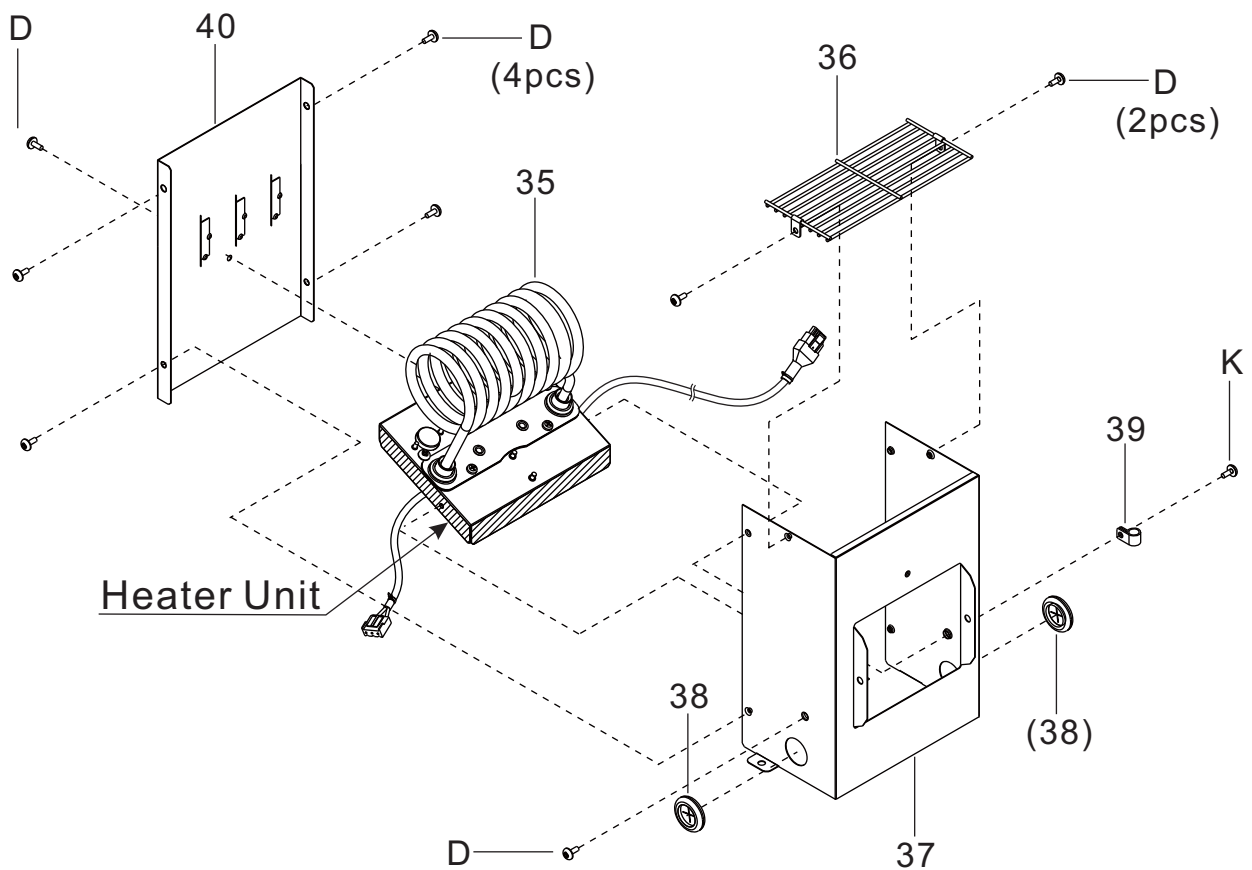

1. Parts Identification

FV-11VHL2

Heater Unit

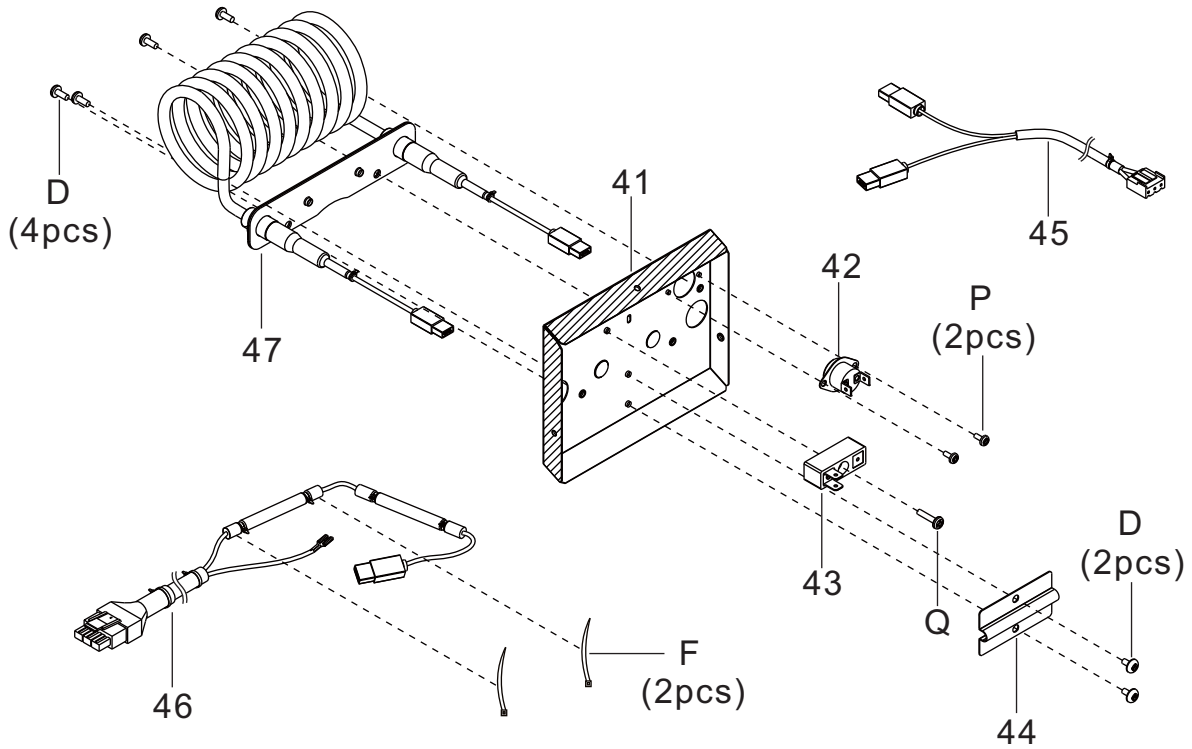

Ventilation Unit

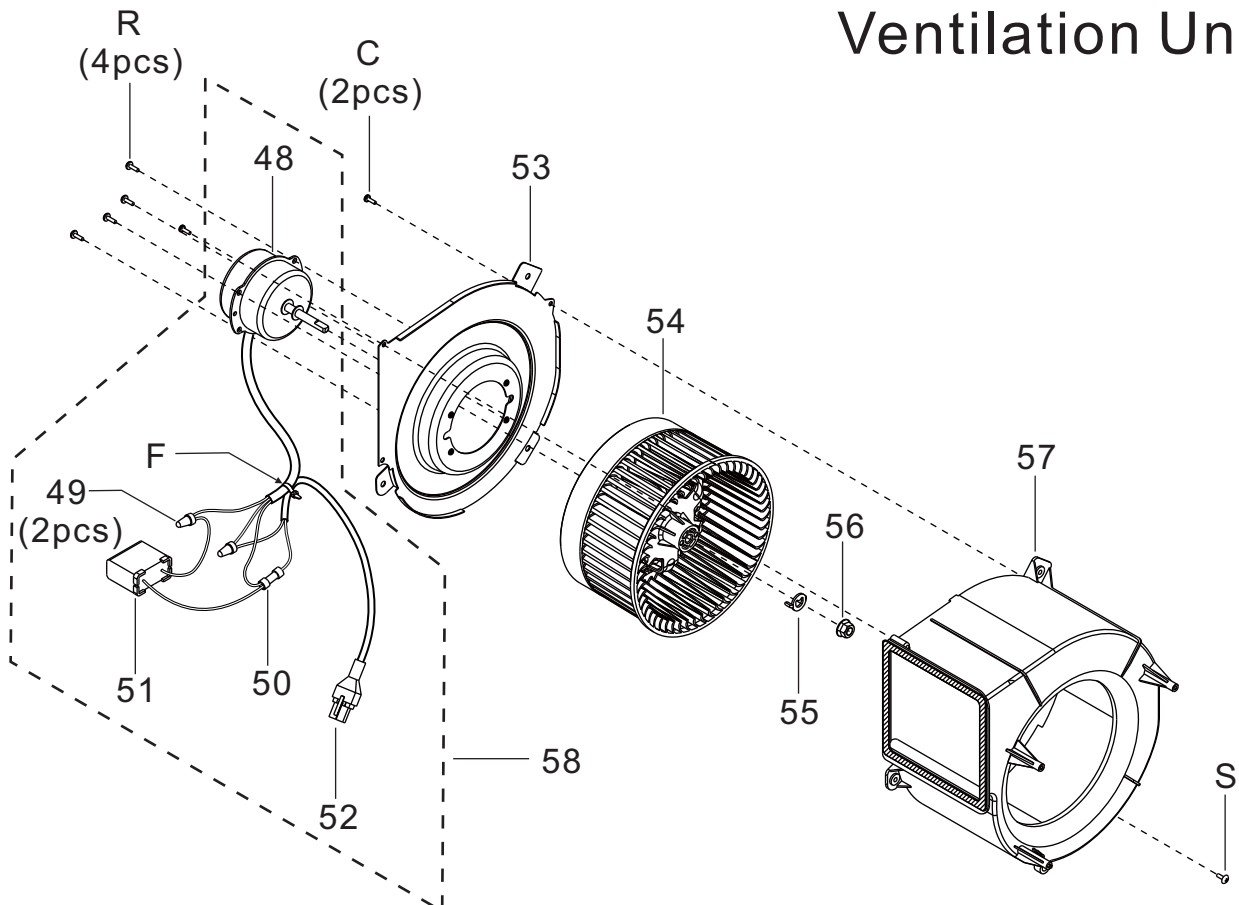

1. Parts Identification

FV-11VHL2

Assembly State

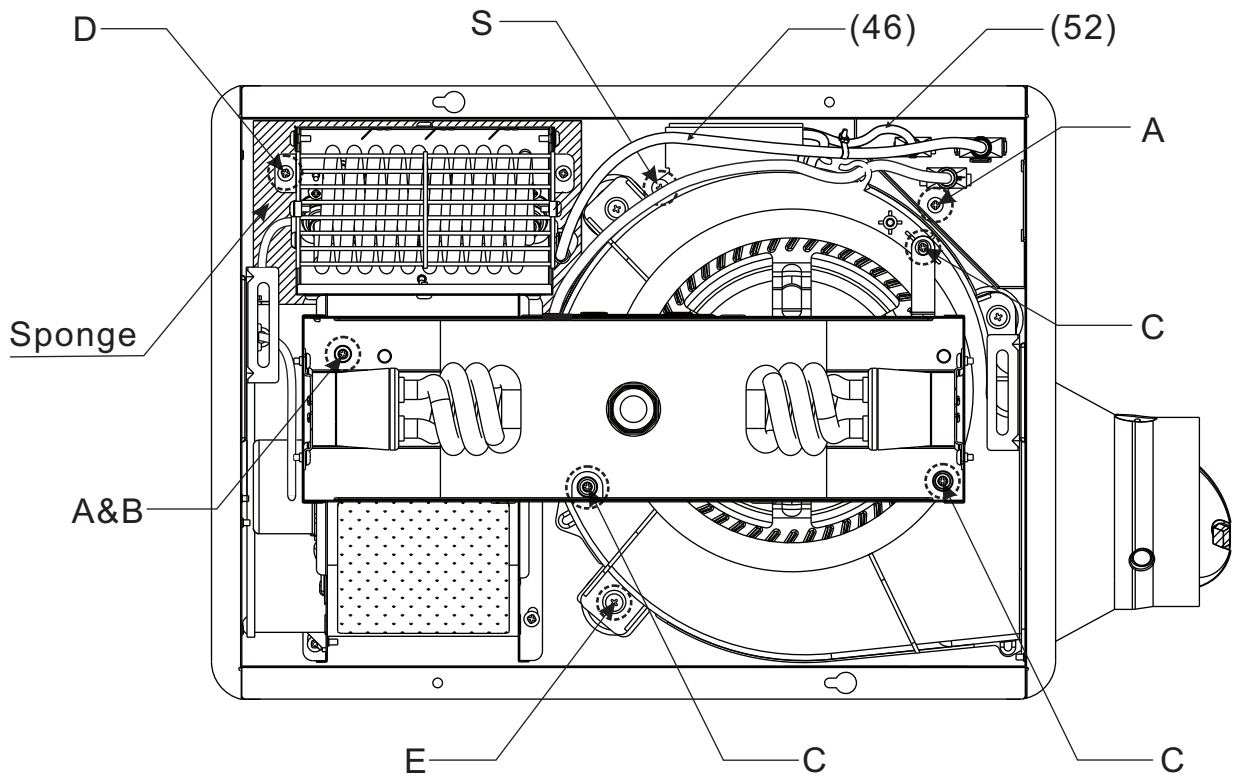

If your machine assembled with the old type of Lighting Assy., please note below points before you order parts.

- 1.If the ballast assy. was damaged,please order the new lighting unit(FFV3420077S) to replace the whole old lighting assy.
- 2.If it just the fluorescent lamp was damaged,please order no.73(FFV3420007S) as below photo.
- 3.The night lamp(FFV420005S) can be common used for old&new type of lighting unit.

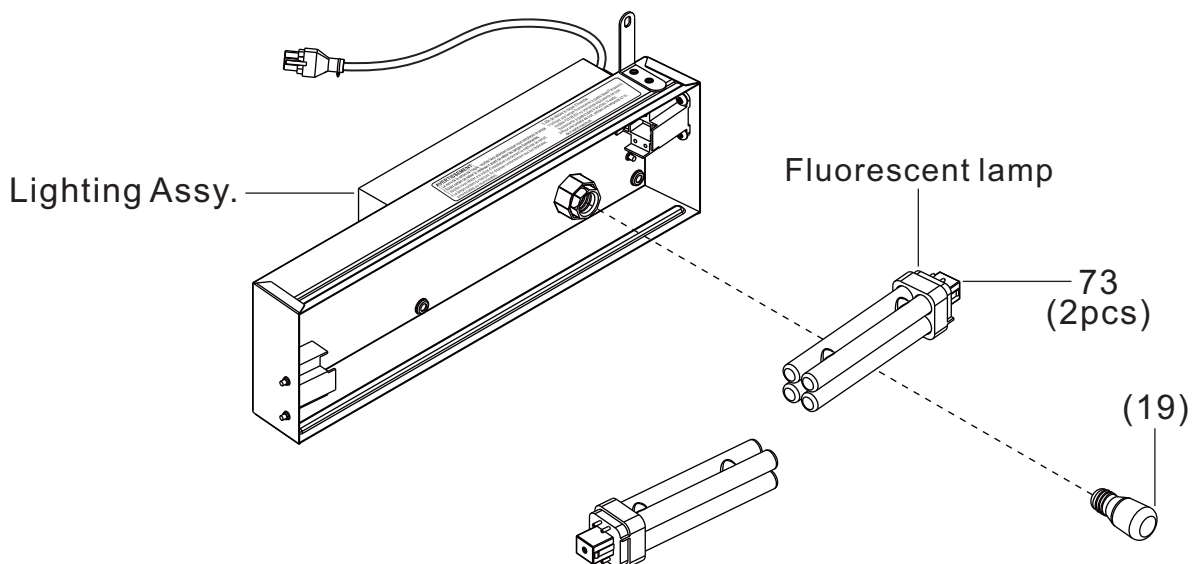

1. Parts Identification

FV-11VHL2

Packing & Accessories Section

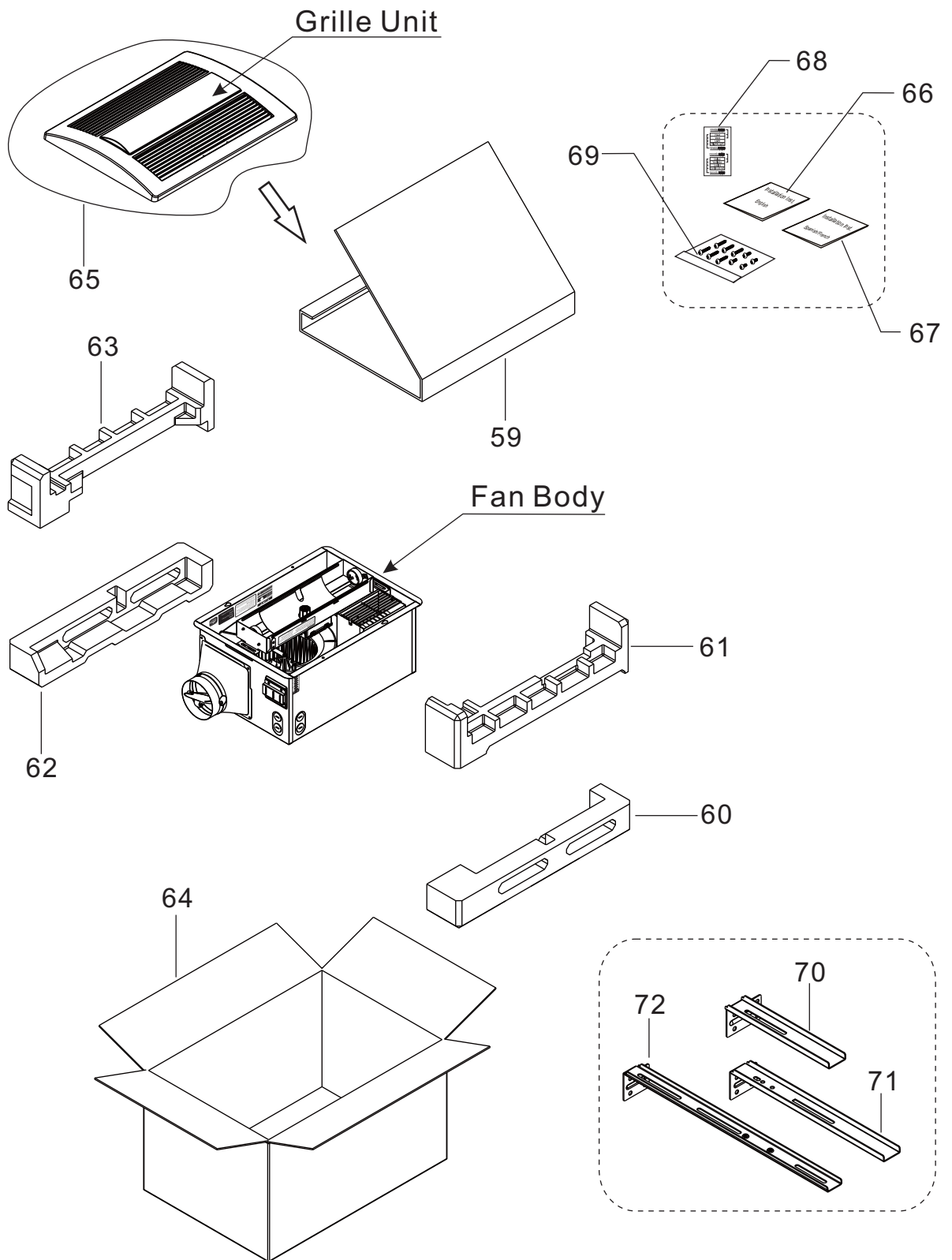

2. Wiring Diagram

FV-11VHL2

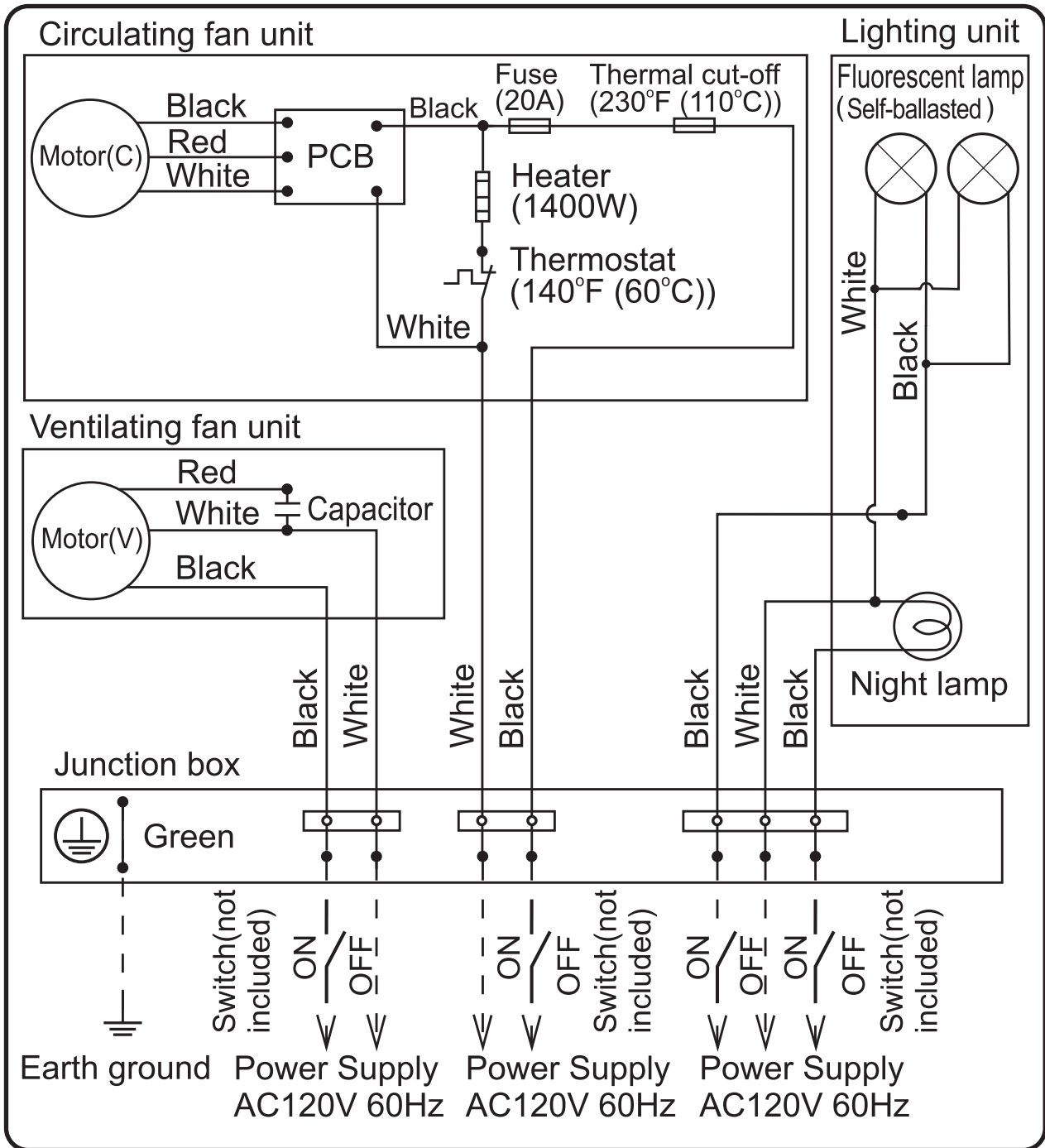

3. Parts List

FV-11VHL2

Main Body Section

No.	Part No.	Part Name	Q'ty	Remark
1	FFV3400115S	Grille Unit	1	
2	FFV3420077S	Lighting Unit	1	⚠
3	FFV0930009S	Circulation Unit	1	⚠
4	FFV6400002S	Ventilation Unit	1	⚠
5	FFV1600090S	Frame Unit	1	
A	FFV7000011S	Machine Screw	1	For Fixing Lighting Unit
B	FFV7010042S	O.T.Washer	1	
C	FFV7000063S	Truss PC Screw	3	For Fixing Lighting Unit
D	FFV7000153S	Truss Tap Screw	4	For Fixing Circulation Unit
E	FFV7000080S	Plus Truss Screw	3	For Fixing Ventilation Unit
F	FFV2530003S	Tie 1	1	

Frame Unit

No.	Part No.	Part Name	Q'ty	Remark
6	FFV0000083S	Adaptor Assy.	1	
7	FFV0420025S	Bracket Cover 1	1	
8	FFV1600091S	Frame Assy.	1	
9	FFV0420013S	Bracket Cover	1	
10	FFV3400113S	Grille Fix Plate	2	
11	FFV2800009S	Junction Box Assy.	1	
12	FFV2800011S	Junction Box Cover	1	
13	FFV0900039S	Connector Wire L	1	⚠
14	FFV0900038S	Connector Wire V	1	⚠
15	FFV0900026S	Connector Wire C	1	⚠
16	FFV1300006S	Earth Lead Wire	1	⚠
A	FFV7000011S	Machine Screw	1	For Fixing Junction Box Cover
D	FFV7000153S	Truss Tap Screw	16	
G	FFV7010002S	Plain Washer	1	
H	FFV7010028S	Spring Washer	1	
I	FFV7000006S	Bind Screw	1	For Fixing Earth Lead Wire ⚠

Lighting Unit

No.	Part No.	Part Name	Q'ty	Remark
17	FFV3420078S	Lighting Assy.	1	⚠
18	FFV3420067S	Fluorescent Lamp	2	New State ⚠
19	FFV3420005S	Night Lamp	1	⚠
73	FFV3420007S	Fluorescent Lamp	2	Old State ⚠

3. Parts List

FV-11VHL2

Circulation Unit

No.	Part No.	Part Name	Q'ty	Remark
20	FFV2220014S	Heater Section	1	⚠
21	FFV0790058S	Casing Section	1	
22	FFV4700012S	PCB Box	1	
23	FFV4700013S	PCB Set	1	⚠
24	FFV4700014S	PCB Box Cover	1	
D	FFV7000153S	Truss Tap Screw	3	For Fixing Casing Section
J	FFV7000172S	Truss Tap Screw	2	For Fixing PCB Box Cover
K	FFV7000009S	Truss Tap Screw	2	For Fixing PCB Box
L	FFV7000171S	Truss Tap Screw	2	For Fixing PCB Set

Grille Unit

No.	Part No.	Part Name	Q'ty	Remark
25	FFV3400116S	Heater Cover	1	
26	FFV5560038S	Spring Set Plate 1	1	
27	FFV5560039S	Spring	2	
28	FFV5560040S	Spring Set Plate	1	
29	FFV5560041S	Spring Set Plate 2	1	
T	FFV3410033S	Lamp Cover	1	
M	FFV7000170S	Truss Screw	1	For Fixing Spring Set Plate 1
N	FFV7000055S	Pan Tap Screw	2	For Fixing Spring Set Plate

Casing Section

No.	Part No.	Part Name	Q'ty	Remark
30	FFV7000147S	Blade Fixing Screw	1	For Fixing Blade Assy.
31	FFV0400092S	Blade Assy.	1	For Circulation Unit
32	FFV3730048S	Motor Support C	1	
33	FFV3700296S	C Motor Assy.	1	120V,60Hz ⚠
34	FFV0790059S	Casing Assy. C	1	
D	FFV7000153S	Truss Tap Screw	3	For Fixing Motor Support C
O	FFV7000173S	Pan Tap Screw	2	For Fixing C Motor Assy.

Heater Section

No.	Part No.	Part Name	Q'ty	Remark
35	FFV2220016S	Heater Unit	1	⚠
36	FFV2220017S	Heater Box Cover	1	
37	FFV2220018S	Heater Box 1	1	
38	FFV0720008S	Coed Bushing	2	
39	FFV0960001S	Nylon Clamp	1	
40	FFV2220015S	Heater Box 2 Assy.	1	
D	FFV7000153S	Truss Tap Screw	8	
K	FFV7000009S	Truss Tap Screw	1	For Fixing Nylon Clamp

3. Parts List

FV-11VHL2

Heater Unit

No.	Part No.	Part Name	Q'ty	Remark
41	FFV2220020S	Heater Fix Plate Assy.	1	
42	FFV5850017S	Thermostat Assy.	1	⚠
43	FFV5820027S	Terminal	1	⚠
44	FFV0940006S	Cut Off Plate	1	For Fixing Cord Assy. C
45	FFV0730027S	PCB Cord Assy.	1	⚠
46	FFV0730028S	Cord Assy. C	1	⚠
47	FFV2220019S	Heater Assy.	1	⚠
D	FFV7000153S	Truss Tap Screw	6	For Fixing Cut Off Plate & Heater Assy.

Heater Unit

No.	Part No.	Part Name	Q'ty	Remark
F	FFV2530003S	Tie 1	2	
P	FFV7000039S	Pan Tap Screw	2	For Fixing Thermostat Assy.
Q	FFV7000155S	Pan Tapping Screw	1	For Fixing Terminal

Ventilation Unit

No.	Part No.	Part Name	Q'ty	Remark
48	FFV3700298S	V Motor Assy.	1	120V,60Hz ⚠
49	FFV0900024S	Connector	2	⚠
50	FFV3470001S	Butt Connector	1	⚠
51	FFV0750107S	Capacitor	1	250V 3.0uF ⚠
52	FFV0730029S	Cord Assy. V	1	⚠
53	FFV3730049S	Motor Support V	1	
54	FFV0400089S	Blade B	1	For Ventilation Unit
55	FFV4670003S	Blade Set Plate	1	
56	FFV7020021S	Nut	1	For Fixing Blade B
57	FFV0790057S	Casing Assy. V	1	
58	FFV3700297S	V Motor Unit	1	⚠
F	FFV2530003S	Tie 1	1	
C	FFV7000063S	Truss PC Screw	2	For Fixing Motor Support V
R	FFV7000097S	Truss Tap Screw	4	For Fixing V Motor Assy.
S	FFV7000099S	Truss Tap Screw	1	For Fixing Casing Cover

3. Parts List

FV-11VHL2

Packing & Accessories Section

No.	Part No.	Part Name	Q'ty	Remark
59	FFV4710264S	Grille Pad	1	
60	FFV4710265S	Left Pad 1	1	
61	FFV4710266S	Left Pad 2	1	
62	FFV4710268S	Right Pad 1	1	
63	FFV4710269S	Right Pad 2	1	
64	FFV9000649S	Packing Case Assy.	1	
65	FFV0450013S	Poly Cover	1	For Grille Unit Packing
66	FFV2540072S	Installation Instruction	1	English,For CA Market/USA Market
67	FFV2540073S	Installation Instruction	1	Spanish,For CA Market
(67)	FFV2540074S	Installation Instruction	1	French,For USA Market
68	FFV5720017S	Switch Labels	1	
69	FFV0010177S	Accessory A	1	
70	FFV5710019S	Suspension Bracket I	1	
71	FFV5710017S	Suspension Bracket III	1	
72	FFV5710018S	Suspension Bracket II	1	