

INSTALLATION INSTRUCTIONS

Ventilating Fan

Model No. **FV-08VQCL6 FV-11VQCL6**

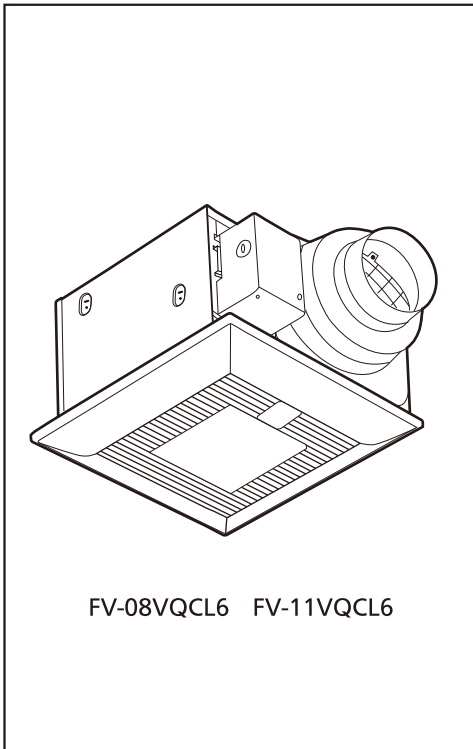

Contents

General Safety Information	2-3
Description	4
Unpacking	4
Supplied Accessories	4
Dimensions	5
Wiring Diagram	5
Switch Indication	6
Operation	6
Installation I (Joist Mounting - I)	7-9
Installation II (Centered/Suspension Bracket Mounting)--	10
Installation III (Joist Mounting - II)	10
Maintenance I (Cleaning)-----	11
Maintenance II (Replacement of lamp)	11-Back cover
Practical Guide To Installation	Back cover
Specifications	Back cover
Product Service	Back cover

READ AND SAVE THESE INSTRUCTIONS

Thank you for purchasing this Panasonic product.

Please read these instructions carefully before attempting to install, operate or service the Panasonic product. Failure to comply with instructions could result in personal injury or property damage. Please explain to users how to operate and maintain the product after installation, and this booklet should be presented to users.

Please retain this booklet for future reference.

GENERAL SAFETY INFORMATION

For Your Safety

To reduce the risk of injury, loss of life, electric shock, fire, malfunction, and damage to equipment or property, always observe the following safety precautions.

Explanation of symbol word panels

The following symbol word panels are used to classify and describe the level of hazard, injury, and property damage caused when the denotation is disregarded and improper use is performed.



Denotes a potential hazard that could result in serious injury or death.



Denotes a hazard that could result in minor injury.

The following symbols are used to classify and describe the type of instructions to be observed.

	This symbol is used to alert users to a specific operating procedure that must be followed in order to operate the unit safely.
	This symbol is used to alert users to a specific operating procedure that must not be performed.
	This symbol is used to alert users not to disassemble the equipment.
	This symbol is used to alert users to make sure of grounding when using the equipment with the grounding terminal.









To reduce the risk of fire, electric shock or injury to persons, observe the following :

- Use this unit only in the manner intended by the manufacturer. If you have any questions, contact the manufacturer.
- Before servicing or cleaning unit, switch power off at service panel and lock the service disconnecting means to prevent power from being switched on accidentally. When the service disconnecting means cannot be locked, securely fasten a prominent warning device, such as a tag, to the service panel.
- Installation work and electrical wiring must be done by qualified person(s) in accordance with all applicable codes and standards, including fire-rated construction.
- Sufficient air is needed for proper combustion and exhausting of gases through the flue (chimney) of fuel burning equipment to prevent back drafting. Follow the heating equipment manufacturer's guideline and safety standards such as those published by the National Fire Protection Association (NFPA), and the American Society for Heating, Refrigeration and Air Conditioning Engineers (ASHRAE) and the local code authorities.
- When cutting or drilling into wall or ceiling, do not damage electrical wiring and other hidden utilities.
- Ducted fans must always be vented to the outdoors.
- If this unit is to be installed over a tub or shower, it must be marked as appropriate for the application and be connected to a GFCI (Ground Fault Circuit Interrupter) - protected branch circuit.
- These models are UL listed for tub and shower enclosures.

GENERAL SAFETY INFORMATION CONTINUED

WARNING

-  Canada only: Not to be installed in a ceiling thermally insulated to a value greater than R40.
-  Do not disassemble the unit for reconstruction. It may cause fire or electric shock.
-  A statement to the effect that when the product is to no longer be used, it must not be left in place but removed, to prevent it from possibly falling.
-  Ceiling joist must be subjected to static load more than five times the weight of the product.
-  Do not install with a method which is not approved in the instructions.
-  Do not use this fan with any solid-state speed control device. Solid state controls may cause harmonic distortion which can cause motor humming noise.
-  This product must be properly grounded.

CAUTION











-  Do not install this ventilating fan where interior room temperature may exceed 104°F(40°C).
-  Make sure that the electric service supply voltage is AC 120V, 60Hz.
-  Follow all local electrical and safety codes, as well as the National Electrical Code (NEC) and the Occupation Safety and Health Act (OSHA).
-  Always disconnect the power source before working on or near the fan, motor, light fixture or junction box.
-  Protect the supply wiring from sharp edges, oil, grease, hot surfaces, chemicals or other objects.
-  Do not kink the supply wiring.
-  Provide make up air for proper ventilation.
-  For general ventilating use only. Do not use to exhaust hazardous or explosive materials and vapors.
-  Do not install the unit where ducts are configured as shown in Fig.A.
-  Not for use in cooking area. (Fig.B)
-  The special-purpose or dedicated parts, such as mounting fixtures, must be used if such parts are provided.



Fig. A

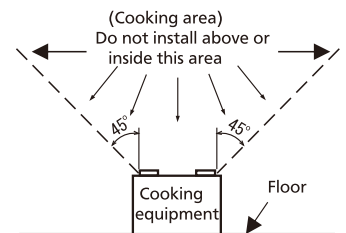

Fig. B

DESCRIPTION

These Panasonic ventilating fan models are listed by UL under UL file No. E78414.

These Panasonic ventilating fan models use a sirocco fan driven by a capacitor motor.

The motor is designed to have an extended service life with reduced energy consumption.

It also incorporates a thermal-cutoff for safety. The grille covering the fan body is a spring-loaded, quick remove type. A damper for preventing air counterflow is provided. The blower uses a high-capacity sirocco fan developed to reduce the noise level.

These Panasonic ventilating fan models are equipped with a motion sensor and a humidity sensor that turn on automatically when motion is detected, when humidity increases rapidly, or when humidity rises above a 30% ~ 80% relative humidity set-point. It is user-adjustable to operate 0.5 ~ 60 minutes after the sensors are no longer detected.

The lighting unit is an energy-saving, lighting device that uses two 13W fluorescent lamps and produces almost the same illumination as a standard 100W incandescent lamp.

FCC Note: This equipment contains two self-ballast fluorescent lamp and is in compliance with Part 18 of the FCC Rules as consumer RF lighting device. These limits are designed to provide reasonable protection against harmful interference in a residential installation. This equipment generates, uses and can radiate radio frequency energy and, if not installed and used in accordance with the instructions, may cause harmful interference to radio communications. However, there is no guarantee that interference will not occur in a particular installation. If this equipment does cause harmful interference to radio or television reception, which can be determined by turning this product on and off, the user is encouraged to try to correct the interference by one of the following measures:

- Reorient or relocate the receiving antenna.
- Increase the separation between the equipment and receiver.
- Connect equipment into outlet on a circuit different from that to which the receiver is connected.
- Consult the dealer or an experienced radio/TV technician for help.

Warning: This equipment must be installed in accordance with installation instructions. Also, any changes or modifications not expressly approved by the party responsible for compliance could void the user's authority to operate this equipment. This device complies with Part 18 of the FCC Rules. Operation is subject to the following two conditions: (1) This device may not cause harmful interference, and (2) this device must accept any interference received, including interference that may cause undesired operation.

Responsible Party: Panasonic Corporation of North America
Two Riverfront Plaza, Newark, NJ 07102





Customer Support: 1-866-292-7299



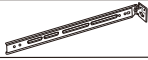
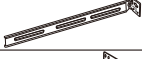

UNPACKING

Unpack and carefully remove the unit from carton.

Refer to the supplied accessories list to verify that all parts are present.

SUPPLIED ACCESSORIES

Part name	Appearance	Quantity
Grille		1
Suspension bracket I		1
Suspension bracket II		1
Suspension bracket III		1
Suspension bracket IV		1
Screw I (ST4.2X6)		2
Screw II (ST4.2X14)		1

Part name	Appearance	Quantity
Long screw (ST4.2X20)		6
Installation instructions		2
Warranty sheet		1
13W Fluorescent lamp		2
4W Night lamp		1

DIMENSIONS

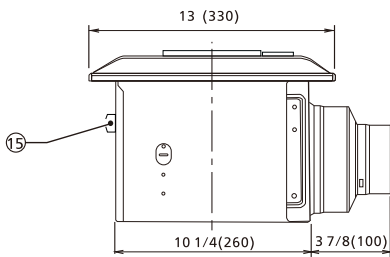
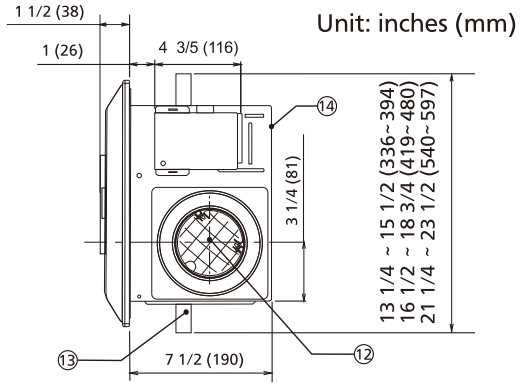
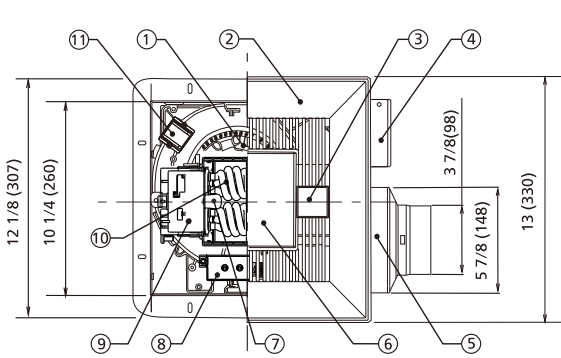

No.	Part name	No.	Part name
1	Blade	9	Lighting unit
2	Grille	10	Fluorescent lamp
3	Motion sensor unit	11	Humidity sensor unit
4	Junction box	12	Damper
5	Adaptor	13	Suspension bracket
6	Lens	14	Fan body
7	Night lamp	15	Bracket cover
8	Switch unit		

WIRING DIAGRAM

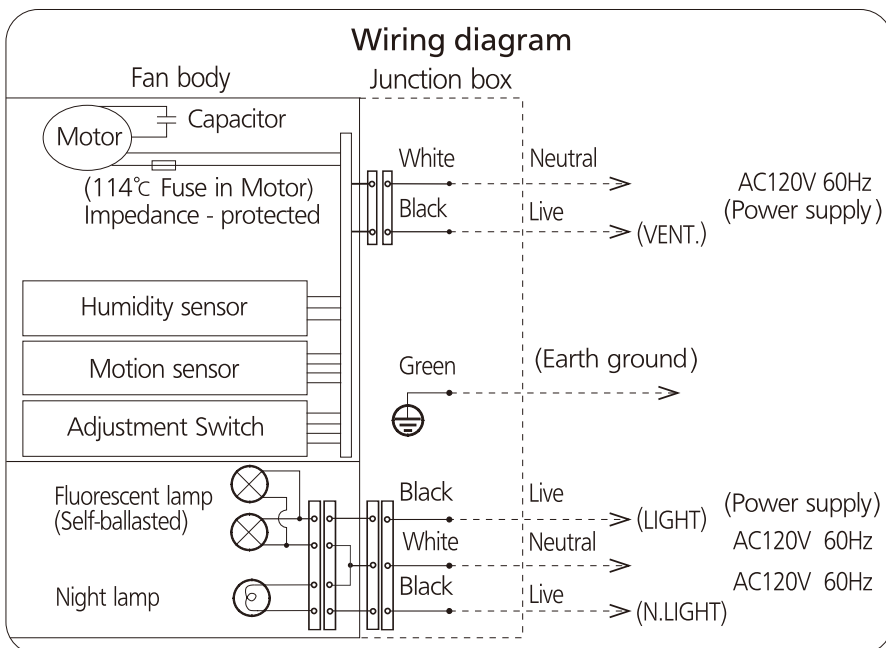

SWITCH INDICATION

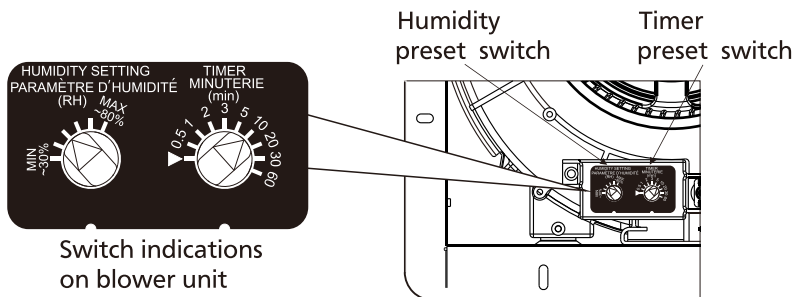

Switch indications on blower unit

Humidity preset switch positions (Tolerance: $\pm 10\%$)

MIN ~MAX	~ 30%	~ 40%	~ 50%	~ 60%	~ 70%	~ 80%
----------	-------	-------	-------	-------	-------	-------

Factory setting: ~ 50% RH ("~" means "about")

Timer preset switch positions

Timer [min]	▶	0.5	1	2	3	5	10	20	30	60
-------------	---	-----	---	---	---	---	----	----	----	----

Factory setting : 10 minutes.

Position "▶" : refer to 0.5 minutes

OPERATION

- Panasonic ventilating fan responds to:
 - (1) Motion sensor detectable condition.
 - (2) Humidity sensor detectable condition.

- Motion sensor detectable condition
 - The delay time is determined by timer preset switch.
 - The unit continues running for an adjustable duration of 0.5 to 60 minutes, after motion is no longer detected.

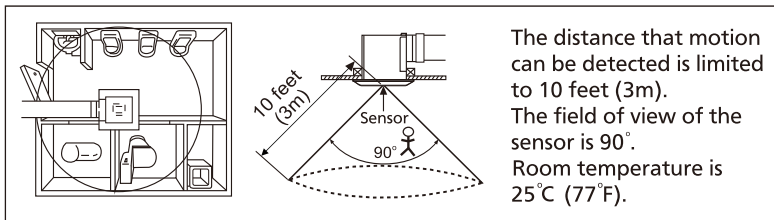

The distance that motion can be detected is limited to 10 feet (3m).
The field of view of the sensor is 90°. Room temperature is 25°C (77°F).

Human activity	INSIDE	OUTSIDE
Fan activity	Stop	When motion is detected, fan runs
		Remains running until the delay time has passed

- Humidity sensor detectable condition
 - rapid to moderate humidity increases and
 - humidity above a 30% ~ 80% relative humidity set-point. (a) and (b) are set with "HUMIDITY SETTING" adjustment. Fan may occasionally turn on when environmental conditions change. The "TIMER" controls how long the fan remains on (a) after rise in humidity and (b) humidity level is below the set-point decreasing about 5% RH.

CAUTION

- ! If this unit is to be install over a tub or shower, for best results, locate it near the shower head.
- ! Long-time operation will influence the detecting precision as dust accumulates. Humidity preset switch may need to be adjusted.
- ! When lighting unit power on and humidity change slowly, this unit may operate when motion is detected or rapid to moderate humidity increases.

INSTALLATION I (JOIST MOUNTING - I)

Joist situation:

Spacing A is 16 inches (406 mm) to 24 inches (609 mm) on center joists

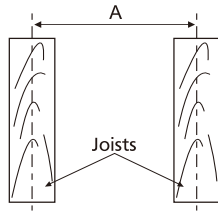

1. If the spacing A is 16 inches (406 mm) to 24 inches (609 mm) on center joists, please follow the installation step as below.

IMPORTANT:

Remove the tape from damper and adaptor before installation. As shown below:

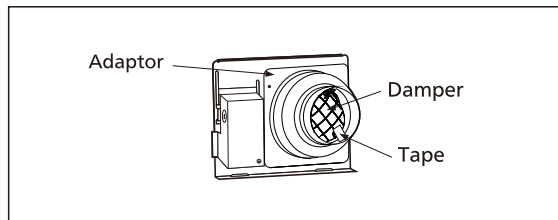

2. Insert the suspension bracket I and II into the fan body. (Select the suspension bracket connection holes as shown below.) (Fig. 1)

Suspension bracket connect method:

Suspension bracket I and II connect with screw I as shown below:

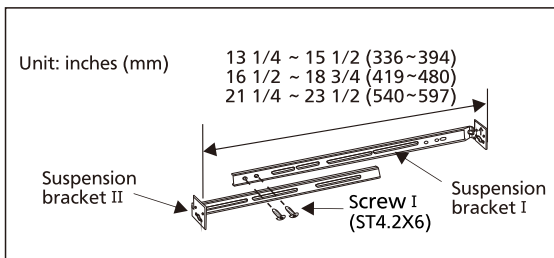

3. Install the suspension bracket and the flange of frame to joists by using long screws (ST4.2X20) and secure it to the fan body by using screw II (ST4.2X14). (Fig.2)

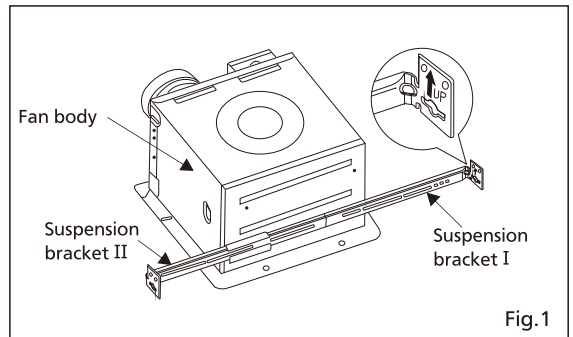

Fig.1

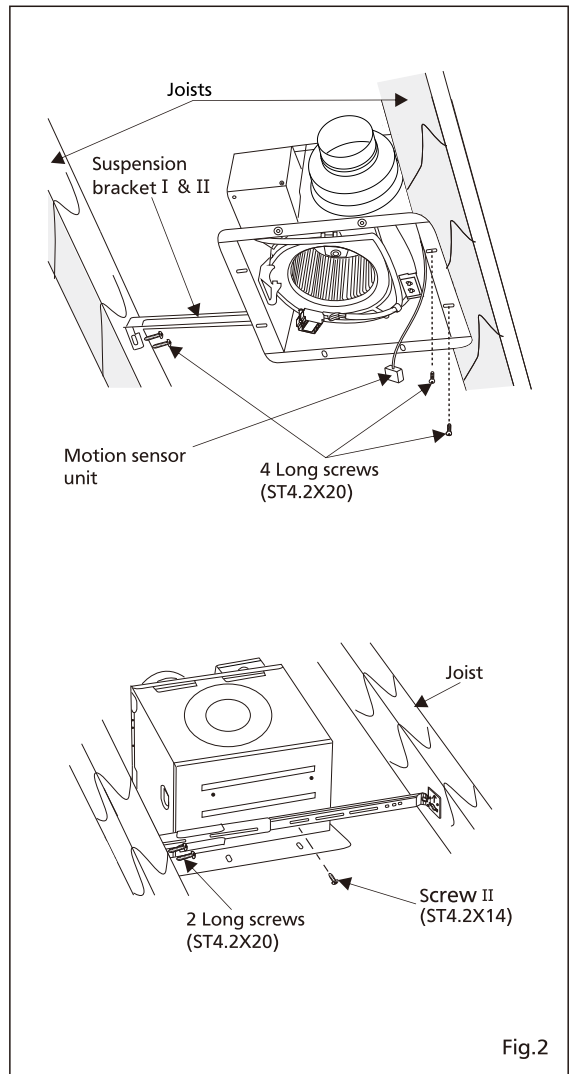
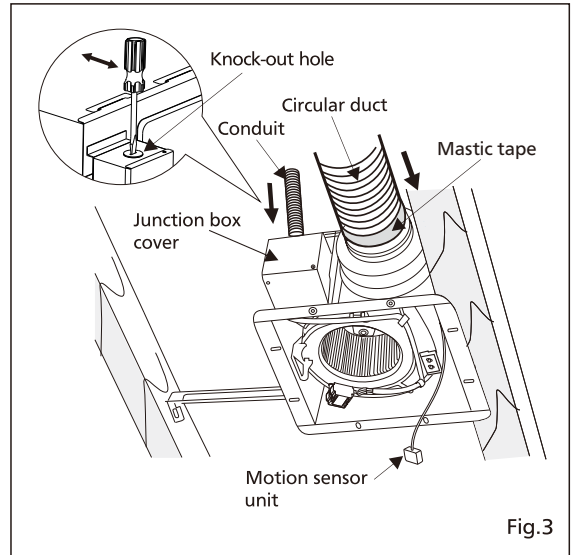

Fig.2

INSTALLATION I (JOIST MOUNTING -I) CONTINUED

4. Install a circular duct and secure it with clamps, or wire ties and seal it with mastic or mastic tape. A 4 or 6 inch circular duct is needed to connect to the relevant part of adaptor. (Fig.3)

5. Remove junction box cover and secure conduit or stress relief to junction box knock-out hole. (Fig.3)



6. Refer to wiring diagram below. Follow all the local electrical safety codes as well as the National Electrical Code (NEC). Using UL approved wire nuts, connect house power wires to ventilating fan wires. (Fig.4)

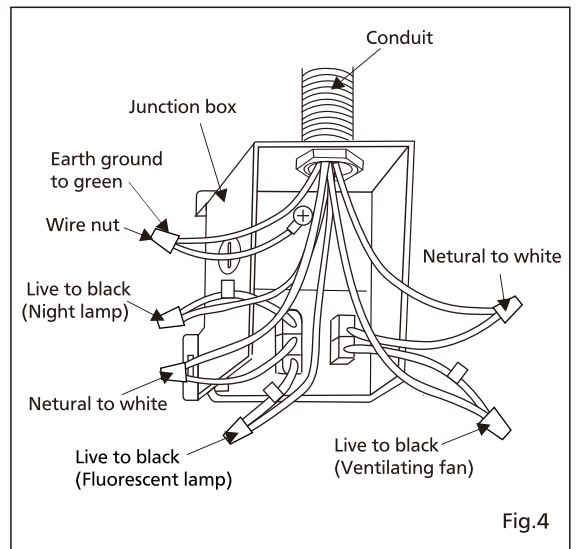

CAUTION

Mount junction box cover carefully so that lead wires are not pinched.

Note:
Wiring detail please refer to the wiring diagram on page 5.

7. Finish ceiling work. Ceiling hole should be aligned with the inside edge of the flange. (Fig.5)

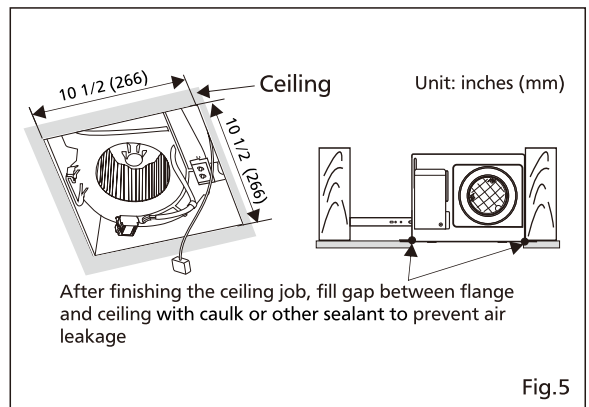
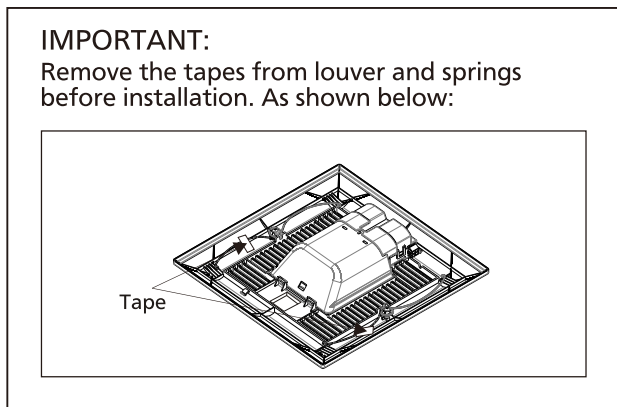

INSTALLATION I (JOIST MOUNTING -I) CONTINUED

8. Remove screw (M4X8). Remove light cover. (Fig.6)

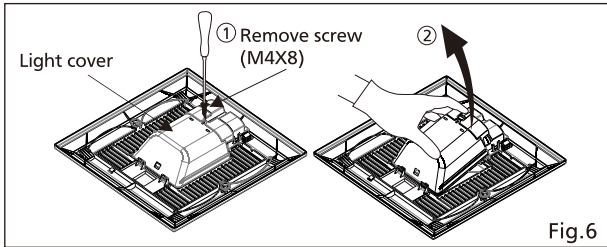

9. Install the night lamp and fluorescent lamps. (Fig.7)

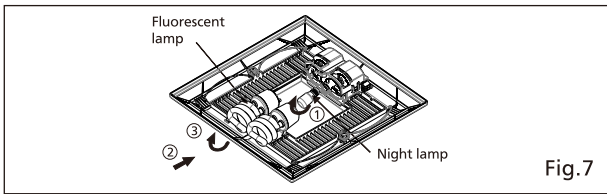

10. Install light cover. (Fig.8)

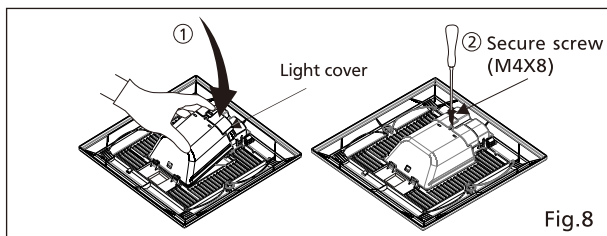

11. Insert the grille mounting spring on the wiring side into the slot and insert the plug connector into the housing of the lighting unit. (Fig.9)

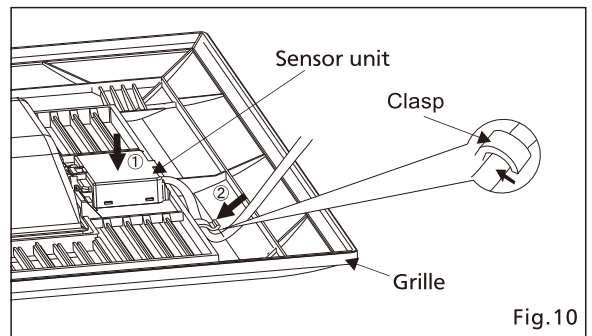
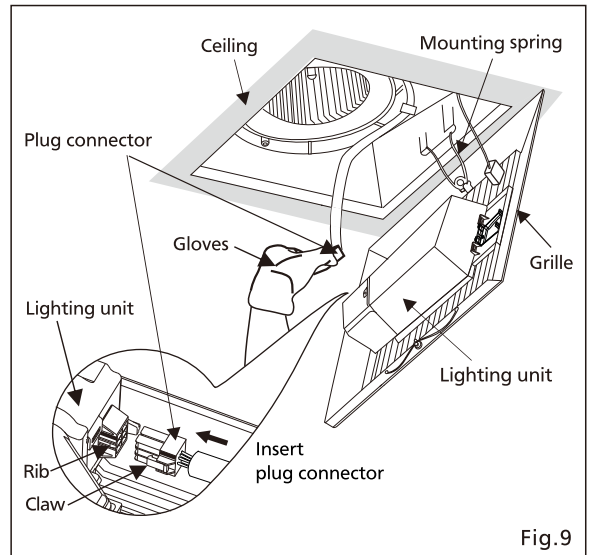

CAUTION

- ! Before turn on the light, make sure the connector at the correct position. If not, the lighting can't work.
- ! The claw of connector must latch the rib completely. (Fig.9)

12. Insert the sensor unit into slot of the grille ; Fix the lead wire of sensor unit into the clasp (1 position).(Fig.10)

13. Adjust timer preset switch and humidity preset switch (Fig.11). Refer to switch indication on page 6.

14. Insert another mounting spring into the slot as shown and mount grille to fan body. (Fig.12)

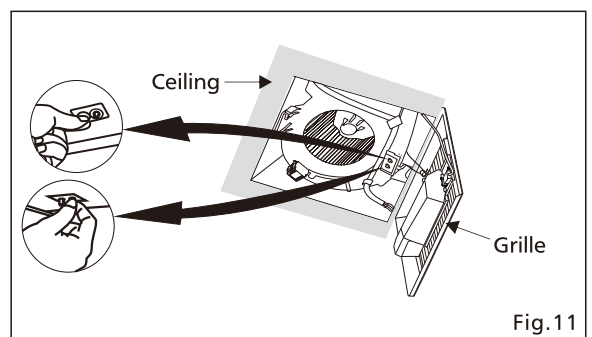

CAUTION

- ! Mount grille carefully so that lead wire of lighting unit is not pinched.

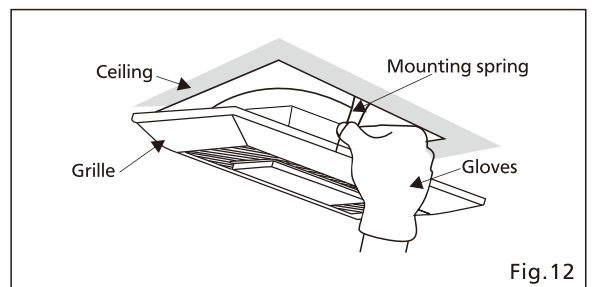

INSTALLATION II (CENTERED/ SUSPENSION BRACKET MOUNTING)

Joist situation:

Spacing A is 16 inches (406 mm) to 24 inches (609 mm) on center joists

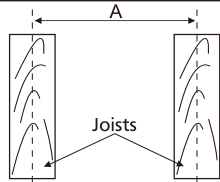

1. If the spacing A is 16 inches (406 mm) to 24 inches (609 mm) on center joists, please follow the installation step as below.
2. Insert the suspension bracket I and II into the fan body and suspension bracket III or IV into the adaptor. (Select the suspension bracket connection holes as shown below.) (Fig. 13, Fig. 14)

Suspension bracket connect method:

Suspension bracket I and II connect with screw I as shown below:

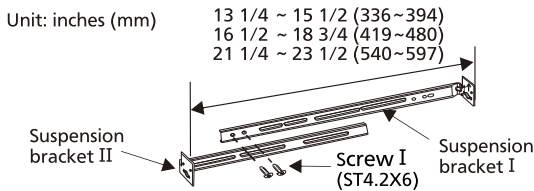

3. Install the suspension bracket to joists by using long screws (ST4.2X20) (Fig. 14) and secure it to the fan body by using screw II (ST4.2X14). (Fig. 15)
4. Follow steps 4 to 14 of installation I (page 8, page 9) to complete the installation work.

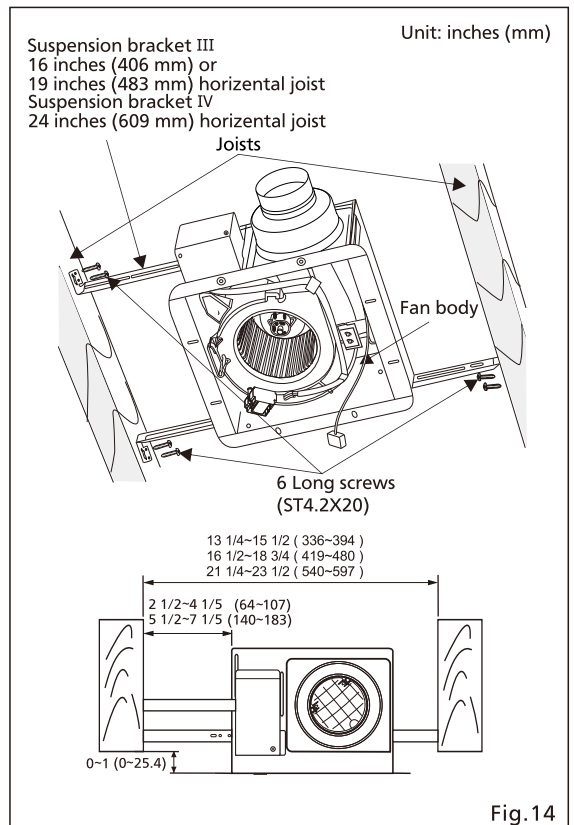
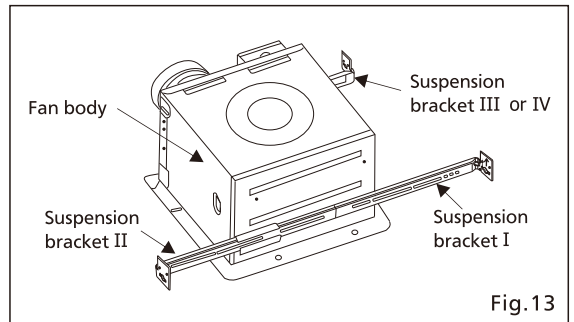
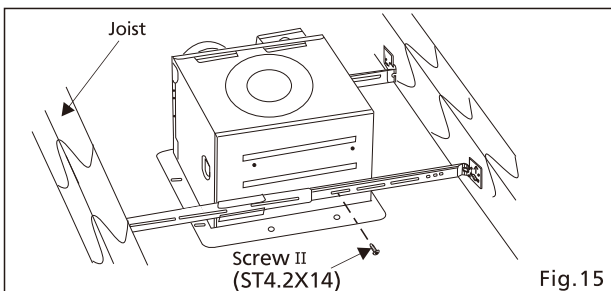

INSTALLATION III (JOIST MOUNTING - II)

Joist situation:

Spacing B is 10 1/2 inches (266 mm) to 11 1/2 inches (292 mm) on joists

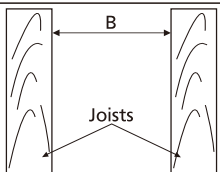

1. If the spacing B is 10 1/2 inches (266 mm) to 11 1/2 inches (292 mm) on joists, please follow the installation step as below.
2. Secure 4 long screws (ST 4.2X20) at flange of frame. (Fig. 16)
3. Follow steps 4 to 14 of installation I (page 8, page 9) to complete the installation work.

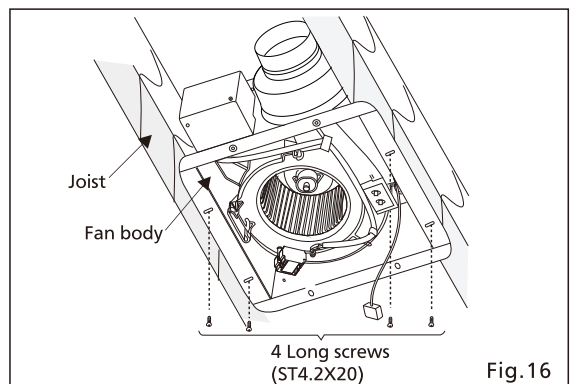





MAINTENANCE I (CLEANING)

WARNING

 Disconnect power source before working on unit.

CAUTION



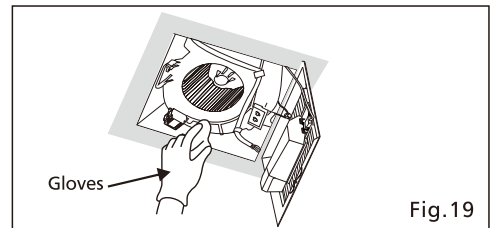
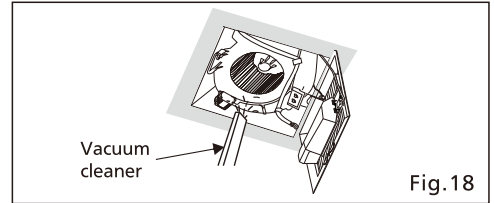
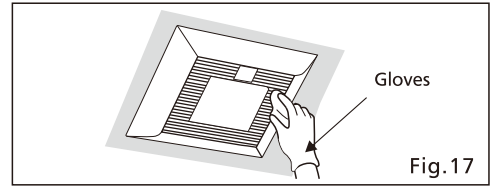

-  Routine maintenance must be done every year.
-  Never use gasoline, benzene, thinner or any other such chemicals for cleaning the ventilating fan.
-  Do not immerse motor in water when cleaning.
-  Do not soak resin parts in water over 140°F (60°C).
-  Do not use cleaning sprays, solvents, or water on or near the sensors.

1. Clean grille. (Don't put into hot water. Use non-abrasive kitchen detergent, wipe dry with clean cloth.) (Fig. 17)
2. The grille should be dry after cleaning.
3. Remove dust and dirt from fan body using a vacuum cleaner. (Fig.18)
4. Using a cloth dampened with kitchen detergent, remove any dirt from fan body. Wipe dry with clean cloth. (Fig.19)
5. Replace grille.



MAINTENANCE II (REPLACEMENT OF LAMP)

WARNING

-  Disconnect power source before working on unit.
-  This is a pin type lamp base and the lamp's glass is fragile. To remove, pull out carefully.
-  4W night lamp has threaded base. Remove by turning counterclockwise.
-  Make sure the temperature of lens and lighting unit has cooled down before maintenance (cleaning) or replacement of lamp.
-  For Canada:

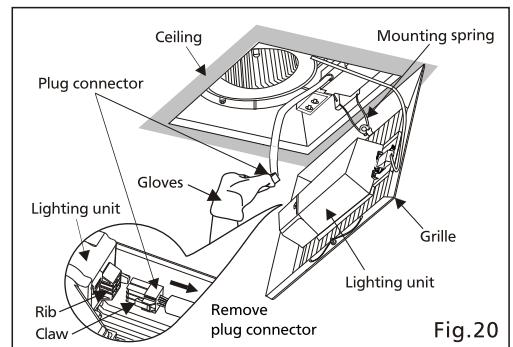

Contains mercury

For more information on safe handling procedures, the measures to be taken in case of accidental breakage and safe disposal options visit: ec.gc.ca/mercure-mercury/.

Dispose of or recycle in accordance with applicable laws.

For the USA:

This product has a fluorescent lamp that contains mercury. Disposal may be regulated in your community due to environmental considerations. For disposal or recycling information, please contact your local authorities or visit Panasonic website:

<http://www.panasonic.com/environmental> or call 1-888-769-0149.

CAUTION

 Remove dust and dirt from light cover and lens, before replace the lamps.

MAINTENANCE II (REPLACEMENT OF LAMP)

1. Remove grille by pulling down one mounting spring. Remove plug connector then pull down the other mounting spring. (Squeeze mounting spring and pull down carefully.) (Fig.20)
2. Remove the screw as shown in step ① of Fig.21. Remove the light cover as shown in step ② of Fig.21.
3. Replace the fluorescent lamps (Maxlite MLS13GU35 13W) as shown in step ① and step ② of Fig.22.
4. Replace the 4W night lamp. (Fig.22) Install the fluorescent lamps (Maxlite MLS13GU3513W) as shown in step ② and step ③ of Fig.7 (page 9).
5. Install light cover. (Fig.8 of page 9)

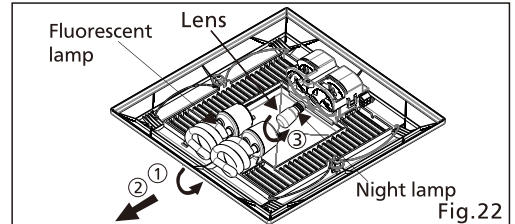
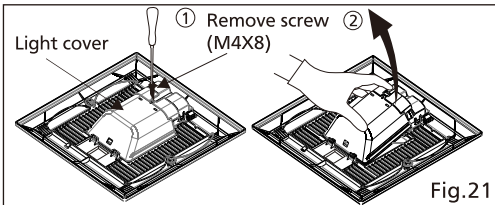

PRACTICAL GUIDE TO INSTALLATION

Properly insulate the area around the fan to minimize building heat loss and gain. (Fig.23)

Loose fill or batt insulation can be placed directly over the fan housing in the attic. Panasonic fans and fan/light combination units do not create excessive heat that is a common problem with recessed light fixtures or some competitors' fan/light combinations. Our efficient, cool-running motors and our fluorescent lamp do not create enough ambient heat to be subjected to these limitations.

The ducting from this fan to the outside of the building has a strong effect on the air flow, noise and energy use of the fan. Use the shortest, straightest duct routing possible for best performance, and avoid installing the fan with smaller ducts than recommended. Insulation around the ducts can reduce energy loss and inhibit mold growth. Fans installed with existing ducts may not achieve their rated air flow.

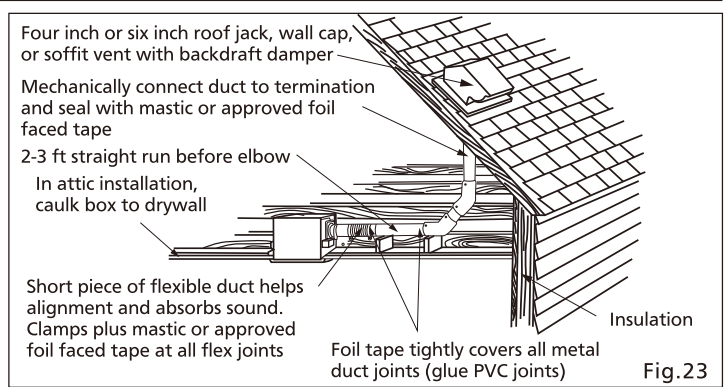

SPECIFICATIONS

Model No.	Air direction	Voltage (V)	Frequency (Hz)	Duct diameter (inches)	Noise (sones)	Power consumption (W)			Speed (rpm)	Air volume at 0.1"WG (CFM)	Weight lb.(kg)
						Fan	Lighting unit				
							Fluorescent lamp	Night lamp			
FV-08VQCL6	Exhaust	120	60	4 or 6	<0.3	15.5	26	4	890	80	11.2 (5.1)
FV-11VQCL6	Exhaust	120	60	4 or 6	0.7	24.5	26	4	1065	110	11.2 (5.1)

HVI Certified performance based on HVI Procedures 915, 916 and 920.

PRODUCT SERVICE

Warning Concerning Removal of Covers.

The unit should be serviced by qualified technicians only.

Your product is designed and manufactured to ensure a minimum of maintenance.

Should your unit require service or parts, call Panasonic Call Center at 1-866-292-7299(USA) or 1-800-669-5165 (Canada).

Panasonic Corporation of North America

Two Riverfront Plaza, Newark, NJ 07102

www.panasonic.com

© Panasonic Corporation 2013 - 2015

Printed in China

Panasonic Canada Inc.

5770 Ambler Drive, Mississauga, Ontario L4W 2T3

www.panasonic.ca