



FEATURES

- Shower pan
- Slip-resistant, textured bottom
- Extended tiling flange (3T)
- Enhanced front profile
- Available in White only
- Patented design features:
 - corner drainage channels
 - step-design finishing guides
 - extended nailing flange
- Center drain
- Solid A² Composite material
- 15-year residential limited warranty

PACKAGED DIMENSIONS (IN)

- 43 ½ x 43 ½ x 8 ¼



What is A² Composite?

Lightweight and durable, our A² Composite is an engineered compound of resin, glass and special fillers formed into sheets. These sheets are then placed under high pressure and heat to liquify the compound, allowing it to flow and take the shape of almost any form imaginable. The results are simple, stylish and a snap to install.





4242CPANNS

42 x 42 x 6
inches

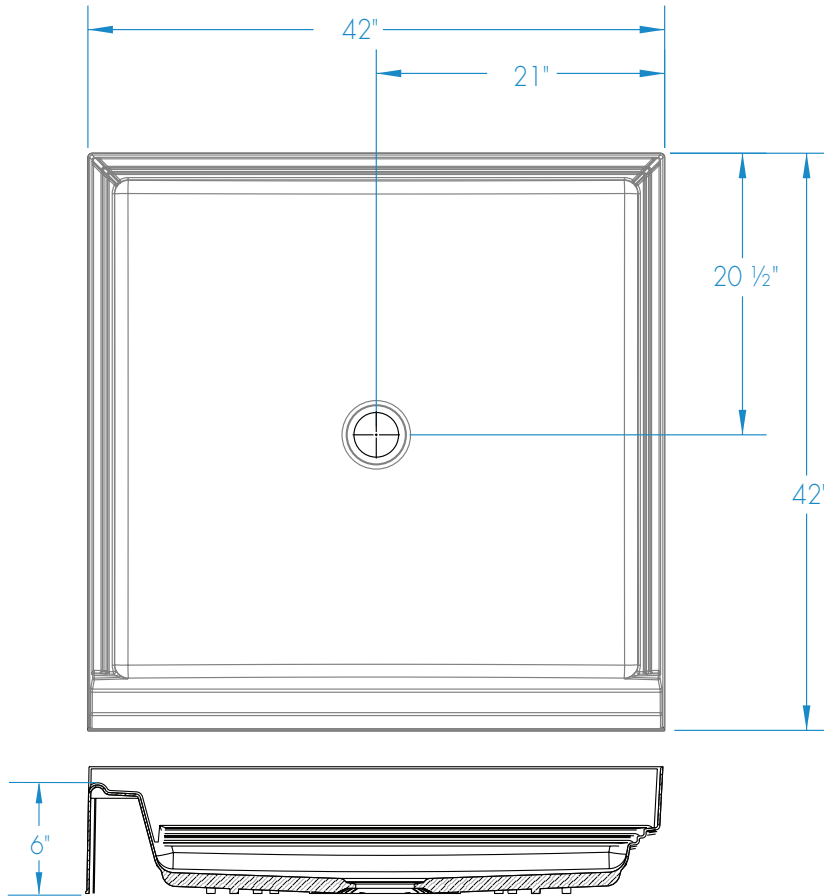

FEATURES

Dimensional Tolerance $\pm \frac{3}{8}$ ". Dimensions needed for site preparation should be measured from the unit. Manufacturer assumes no responsibility for preparatory work.

Model #	Material	Drain	Net Wt. lbs	Pkg. Wt. lbs
Shower Pan #4242CPANNS	A ² Composite	Center	42	47

DIMENSIONS

Specifications	inches
Width: Overall / Net	42
Depth: Overall / Net	42
Height: Overall / Net	7 / 6
Enclosure Opening	-
Skirt Height	6
Drain Rough-In (from Back Wall)	20 ½
Drain Rough-In (from Side Wall)	21
Drain: Diameter / Clearance	3 ¼ / 3/8

FRAMING DIMENSIONS inches

Type	D Depth	W Width	H Height	A	B	C
Alcove	42	42	-	Box Out	21	20 ½

