



FEATURES

- Above Floor Rough (AFR)
- Pre-Leveled base
- Slip resistant, textured bottom
- Available in White and Biscuit
- Left, right drain
- Durable high gloss finish
- 15-year residential limited warranty

OPTIONS

- Coordinating wall sets available
*See A² price list for tub-shower assembly and/or wall set part numbers



White



Biscuit



What is A² Composite?

Lightweight and durable, our A² Composite is an engineered compound of resin, glass and special fillers formed into sheets. These sheets are then placed under high pressure and heat to liquify the compound, allowing it to flow and take the shape of almost any form imaginable. The results are simple, stylish and a snap to install.





6030CTM

60 x 30 x 18
inches

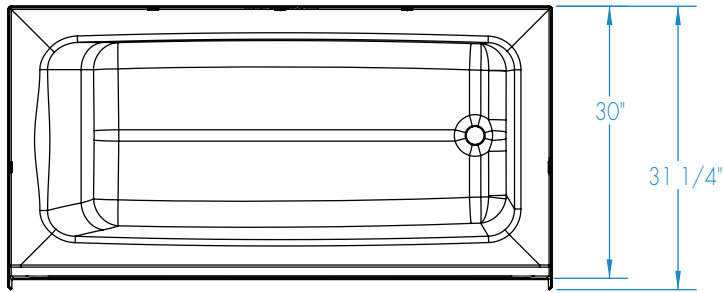

AFR: Allows for above the floor installation of waste, overflow and drainage.

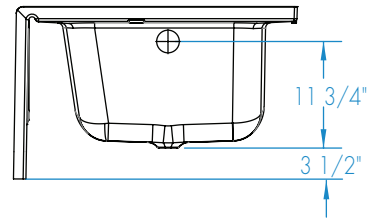
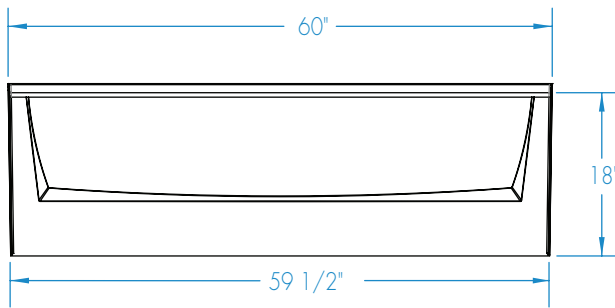

FEATURES

Dimensional Tolerance $\pm \frac{3}{16}$ ". Dimensions needed for site preparation should be measured from the unit. Manufacturer assumes no responsibility for preparatory work.

Model #	Material	Jets	Motor	Controls	Drain	Net Wt. lbs	Pkg. Wt. lbs
AFR Soaker #6030CTM	A ² Composite	-	-	-	LH or RH	54	59

DIMENSIONS

Specifications	inches
Width: Overall / Net	60
Depth: Overall / Net	31 1/4 / 30
Height: Overall / Net	19 1/2 / 18
Enclosure Opening	-
Skirt Height	18
Drain Rough-In (from Back Wall)	14 1/4
Drain Rough-In (from Side Wall)	2 7/8
Drain: Diameter / Clearance	2 / 3 1/2

FRAMING DIMENSIONS inches

Type	D Depth	W Width	H Height	A	B	C
Alcove	31 1/4	60	19	Box Out	2 7/8	14 1/4

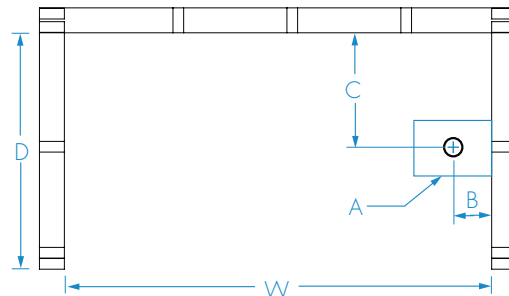

SUMP DATA

Top of Drain to Bottom of Overflow	Capacity to Overflow gal	Min. Operating Capacity gal	WIDTH @ centerline		DEPTH @ centerline	
			Top	Bottom	Top	Bottom
9 7/8	37	-	51 1/2	45 1/2	22 1/4	20 1/2