

Nominal Size:
M148/S148
M160/S160
M260

Overall Dimensions: Inches (mm)
48"W x 36"D x 90"H (1219 x 915 x 2285)
60"W x 36"D x 90"H (1525 x 915 x 2285)
60"W x 34"D x 90"H (1525 x 865 x 2285)

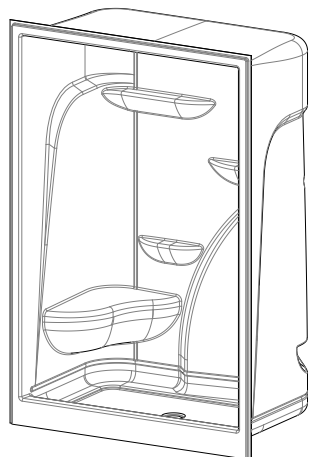

M160 with Seat

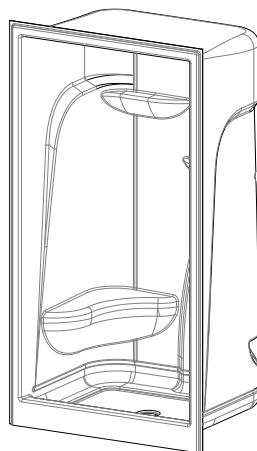

M148 with Seat

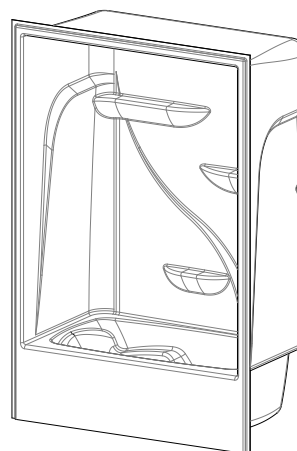

M260

A. PRE-INSTALLATION PLANNING

- Unit must be placed within bathroom area before completion of door framing or, if preferred, studs may be omitted or knocked-out to permit unit placement.
- Make sure framed-in alcove is of proper size, square and plumb; check floor for levelness.
- If fire-rated alcove is required, approved finish material must be in place prior to unit installation to meet fire safety requirements of local building code and/or FHA/HUD Minimum Property Standards. **NOTE: finished alcove must have interior dimensions shown on rough-in diagram to permit installation of unit.**
- Casting plaster or other foundation materials are recommended. Shimming may be needed to level unit and for additional support.
- If a shower door is to be installed, measure enclosure opening before ordering, or order a Aquatic Door for a quality custom fit.
- If dome light will be installed, cut out required area within molded 12" (305) sq. flat area in center of dome. Use fine-tooth or abrasive-grit blade. Cut from inside. Light fixture must have UL label, and be water- and steam-tight.

B. CRITICAL PRE-INSTALLATION ROUGH-IN REQUIREMENTS

Make sure these provisions have been made before attempting to install unit:

- 6" (150) diameter floor opening for 2" (50) IPS and drain connection [Fig. 1] for shower unit.
- 6" x 12" (150 x 305) diameter floor opening for drain and overflow plumbing [Fig.1] for tub-shower unit. Be sure hole location matches type of tub-shower: left or right hand unit.
- Front corner posts are double 2" x 4" (50 x 100) studs for flush mounting.

ALCOVE			
DIMENSION	M148 S148	M160 S160	M260
W	46" (1170)	58" (1475)	58" (1495)
D	36" (915)	36" (915)	34" (865)

HEIGHT, WIDTH DIMENSIONAL TOLERANCE +0, - $\frac{3}{8}$ " (± 5 mm)
GENERAL DIMENSION TOLERANCE: + $\frac{3}{8}$ " (10mm), - $\frac{3}{8}$ " (5mm)

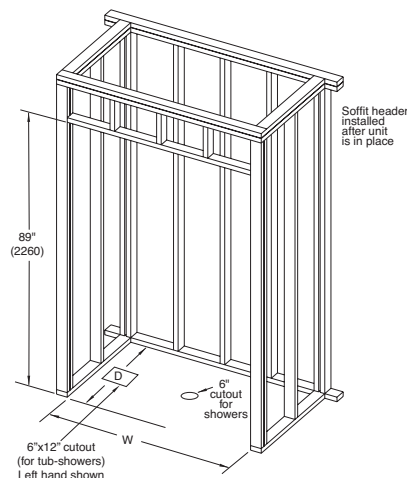
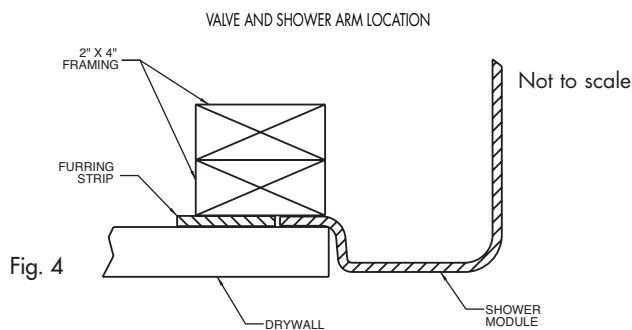
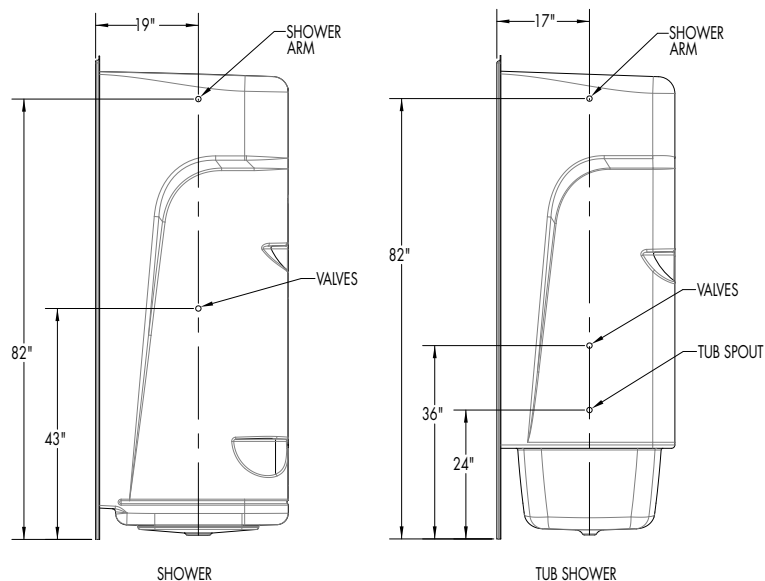

Fig. 1 Framing

C. INSTALLATION PROCEDURE

- To avoid obstruction, make sure that supply lines and valve plumbing are not strapped to studs and do not project into alcove.
- On outside of plumbing endwall of unit, mark locations of shower arm, valve/s and tub spout in accordance with dimensions shown in Fig. 2 and Fig. 3. Double-check location of marks. Drill 1/4" (5) pilot holes.
- From inside of unit [glossy side], using proper size hole saw with fine-tooth or abrasive grit cutting edge, cut openings for shower arm, valve/s and tub spout. Fasten shower drain fitting at this time.
- If using casting plaster, mix 3 gallon bucket. Place 3 or 4 mounds starting near drain approximately twice as high as the cavity under the unit.
- Place unit into alcove — use care not to crack or break lower corners when pushing or walking unit into alcove.
NOTE: If shower drain fitting does not nest with drain pipe, tilt unit forward while adjusting drain pipe.
Be sure unit's weight does not rest on drain pipe.
- Level unit for proper drainage. Use a 3' (915) long level on top of dam and on front face. Shim where necessary to assure level unit, or depress grout mounds until level.
- Install soffit header above unit as shown in Fig. 1.
- Using holes provided, screw [do not nail] unit to framing. For wood framework, use #8 x 1 1/2" (40) flathead wood screws. For metal framework, use #8 x 1 1/2" (40) sheet metal screws. Start at holes at lower left and right, proceeding upward alternately on each side and across the top. Drive screws snugly but do not overtighten. **CAUTION:** Do not nail into face of mounting flange. Do not strike flange with any tool. Striking unit may cause irreparable damage.
- Make final connections to supply lines and waste pipe in accordance with plumbing code requirements. Strap water lines and valve/s to studs.
- Finish front of the unit with drywall, as shown [Fig. 4].



D. CLEAN-UP

- DO NOT REMOVE WARRANTY LABEL!** Leave on the unit for owner or occupant. [Code Requirement]
- Use sponge with warm water and a liquid non-abrasive detergent. **DO NOT USE** scouring pads, steel wool, metal scrapers, sand paper or anything else that might scratch, mar, or dull the finish. Plaster, latex paint, or other foreign materials may be removed with water, liquid detergent, and plastic scraper. **CAUTION: DO NOT USE heat or solvent based cleaning fluids.**
- Dull areas and light scratches may be removed by buffing with a light colored automotive rubbing compound and soft cloth. Entire unit can be waxed with light colored automotive wax. **DO NOT WAX BOTTOM OF UNIT.**
- PREVENT STAINING.** Remove all debris before leak testing for plumbing inspection. **Drain** and **wipe** clean immediately after testing and inspection.

Field Service/Repairs

West Central/Northwest/Rocky Mtn
PH:800-335-5151 ext: 51228
FAX:702-864-2130

Southwest/South Central
PH:800-876-3044 ext:88160
FAX: 972-227-0769

North Central/North East
PH: 800-876-3044 ext: 88150
FAX:972-227-0769

Mid-Atlantic
PH: 800-444-0832 ext: 44141
FAX: 434-575-0989

Customer Service/Sales Order

Customer Service/Sales Order
C/O Skymark Tower
1521 No. Cooper, Ste. 500
Arlington, TX 76011
PH: 800-945-2726, 817-801-8300
FAX: 866-544-5353

Technical Services Department
8101 E. Kaiser Blvd.
Anaheim, CA 92808
PH: 800-877-2005, 714-993-1220