

AXOR Select°
18312181

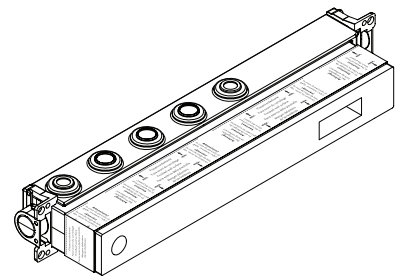

AXOR Select°
18311181

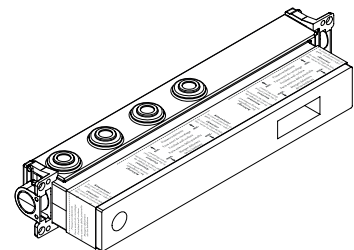

AXOR Select°
18310181

EN / Assembly instructions
FR / Instructions de montage
ES / Instrucciones de montaje

ENGLISH

TECHNICAL INFORMATION

Water pressure	
Recommended	15 - 75 PSI (0.1 - 0.5 MPa)
Maximum	145 PSI (1 MPa)
Hot water temp.	
Recommended	120°-140° F (48° - 60° C)*
Maximum	158°F (70° C)*

* Please know and follow all applicable local plumbing codes when setting the temperature on the water heater.

INSTALLATION CONSIDERATIONS

- / Please read over these instructions thoroughly before beginning installation. Make sure that you have all tools and supplies needed to complete the installation.
- / Inspect this product thoroughly before installation. Claims for shipping damage made after installation will not be honored.
- / For best results, Hansgrohe recommends that this unit be installed by a licensed, professional plumber.
- / The thermostatic cartridge and shutoff cartridges are included with the trim kit.
- / Rough 18310181 only: this valve is for one shower function plus a handshower. It is for use with trim sets 18355XX1 and 12571XX1.
- / Rough 18311181 only: this valve is for two shower functions plus a handshower. It is for use with trim sets 18356XX1, 12572XX1, 12793XX1, and 12593XX1 (not included).
- / Rough 18312181 only: this valve is for three shower functions plus a handshower. It is for use with trim sets 12573XX1, 12594XX1, and 12796XX1.

⚠ The thermostatic mixer must be installed with the ¾" hot and cold inlet ports facing downwards (illustration A).

⚠ Do not install the mixer with the inlets facing upwards or to the side (illustration B).

/ The rough does not include stops. If stops are desired, install them on the hot and cold supplies in an easily accessible location outside the shower. Stops are not available from Hansgrohe.

/ The thermostatic mixer is for use with shower heads rated at 1.3 GPM (4.9 L/min) or higher.

/ To prevent scald injury, the maximum output temperature of the shower mixing valve (not included) must be no higher than 120°F (49°C). In Massachusetts, the maximum output temperature can be no higher than 112°F (44°C).

/ Keep this booklet and the receipt (or other proof of date and place of purchase) for this product in a safe place. The receipt is required should it be necessary to request warranty parts.

FRANÇAIS

DONNÉES TECHNIQUES

Pression d'eau	
recommandée	15 - 75 PSI (0.1 - 0.5 MPa)
maximum	145 PSI (1 MPa)
Température d'eau chaude	
recommandée	120°-140° F (48° - 60° C)*
maximum	158°F (70° C)*

* Vous devez connaître et respecter tous les codes de plomberie locaux applicables pour le réglage de la température du chauffe-eau.

À PRENDRE EN CONSIDÉRATION POUR L'INSTALLATION

/ Pour de meilleurs résultats, Hansgrohe recommande que ce produit soit installé par un plombier professionnel licencié.

/ Avant son montage, s'assurer que le produit n'a subi aucun dommage pendant le transport. Après le montage, tout dommage de transport ou de surface ne pourra pas être reconnu.

/ Veuillez lire attentivement ces instructions avant de procéder à l'installation. Assurez-vous de disposer de tous les outils et du matériel nécessaires pour l'installation.

/ La cartouche thermostatique et les cartouches d'arrêt sont fournies avec le jeu de garniture.

/ Pièce intérieure 18310181 uniquement : cette valve est destinée à une fonction de douche plus une douchette. À utiliser avec les garnitures 18355XX1 ou 12571XX1 (non fournie).

/ Pièce intérieure 18311181 uniquement : cette valve est destinée à deux fonctions de douche plus une douchette. À utiliser avec les garnitures 18356XX1, 12572XX1, 12793XX1, ou 12593XX1 (non fournie).

/ Pièce intérieure 18312181 uniquement : cette valve est destinée à trois fonctions de douche plus une douchette. À utiliser avec les garnitures 12573XX1, 12594XX1, ou 12796XX1 (non fournie).

⚠ Le mitigeur thermostatique doit être installé avec les ports d'alimentation d'eau chaude et froide de ¾ po orientés vers le bas (illustration A).

⚠ N'installez pas le mitigeur avec les ports orientés vers le haut ou le côté (illustration B).

/ La pièce intérieure n'inclut pas de robinets d'arrêt. Si vous voulez des robinets d'arrêt, installez-les sur les conduites d'alimentation d'eau chaude et d'eau froide dans un endroit facilement accessible à l'extérieur de la douche. Les robinets d'arrêt ne sont pas disponibles auprès de Hansgrohe.

/ Ce produit devrait être seulement utilisé avec les pommes de douche évaluées à 1.3 GPM (5.0 L/min) ou plus.

/ Pour empêcher des blessures par ébullition, la température de sortie maximale du robinet de douche ne doit pas excéder 120°F (49°C). Au Massachusetts, la température de sortie maximale du robinet de douche ne doit pas excéder 112°F (44°C).

/ Conservez ce livret et le reçu (ou une autre preuve sur laquelle figurent la date et l'endroit de l'achat) pour ce produit dans un endroit sûr. Le reçu est requis si vous commandez des pièces sous garantie.

ESPAÑOL

DATOS TECNICOS

Presión en servicio
recomendada 15 - 75 PSI (0.1 - 0.5 MPa)
max. 145 PSI (1 MPa)

Temperatura del agua caliente
recomendada 120°-140° F (48° - 60° C)*
max. 158° F (70° C)*

* Debe conocer y cumplir todos los códigos locales aplicables para ajustar la temperatura del calentador de agua.

CONSIDERACIONES PARA LA INSTALACIÓN

/ Para obtener mejores resultados, la instalación debe estar a cargo de un plomero profesional matriculado.

/ Antes del montaje se debe examinarse el producto contra daños de transporte. Después de la instalación no se reconoce ningún daño de transporte o de superficie.

/ Antes de comenzar la instalación, lea estas instrucciones detenidamente. Asegúrese de tener las herramientas y los insumos necesarios para completar la instalación.

/ El cartucho termostático y los cartuchos de cierre se incluyen en el kit de pieza exterior.

/ Únicamente pieza interior de válvula 18310181: Esta válvula es para una función de ducha más una ducha de mano. Debe instalarse con una pieza exterior 18355XX1 o 12571XX1 (no incluida).

/ Únicamente pieza interior de válvula 18311181: Esta válvula es para dos funciones de ducha más una teleducha. Debe instalarse con una pieza exterior 18356XX1, 12572XX1, 12793XX1, o 12593XX1 (no incluida).

/ Únicamente pieza interior de válvula 18312181: Esta válvula es para tres funciones de ducha más una teleducha. Debe instalarse con una pieza exterior 2573XX1, 12594XX1, o 12796XX1 (no incluida).

⚠ El mezclador termostático debe instalarse con los puertos de entrada de agua caliente y fría de 3/4" mirando hacia abajo (ilustración A).

⚠ No instale el mezclador con las entradas mirando hacia arriba o al costado (ilustración B).

/ La pieza interior no incluye topes. Si desea topes, instálelos en los suministros de agua caliente y fría en una ubicación de fácil acceso fuera de la ducha. Hansgrohe no le proporciona los topes.

/ Este producto debe ser utilizado sólo con alcachofas de la ducha valoradas en 1.3 GPM (5.0 L/min) o más.

/ Para evitar escaldaduras, la máxima temperatura de salida de la válvula de la ducha no debe exceder los 120°F (49° C). En Massachusetts, la máxima temperatura de salida de la válvula de la ducha no debe exceder los 112°F (44° C).

/ Mantenga este folleto y el recibo (u otro comprobante del lugar y fecha de compra) de este producto en lugar seguro. El recibo se requiere en caso de ser necesario solicitar piezas bajo garantía.

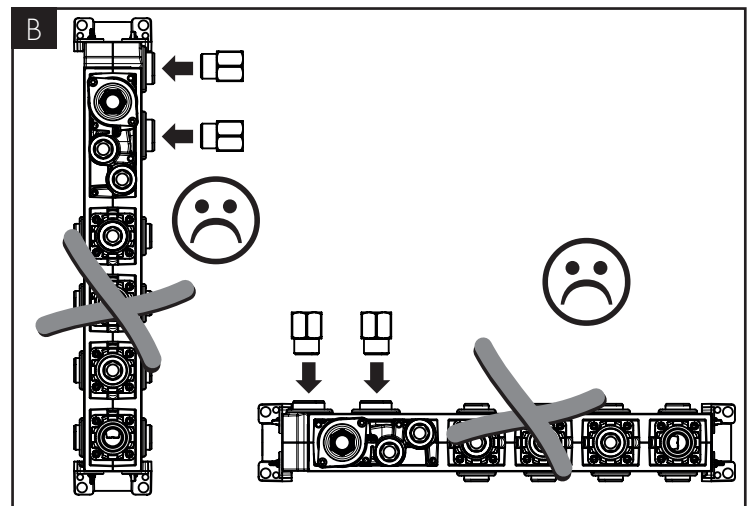
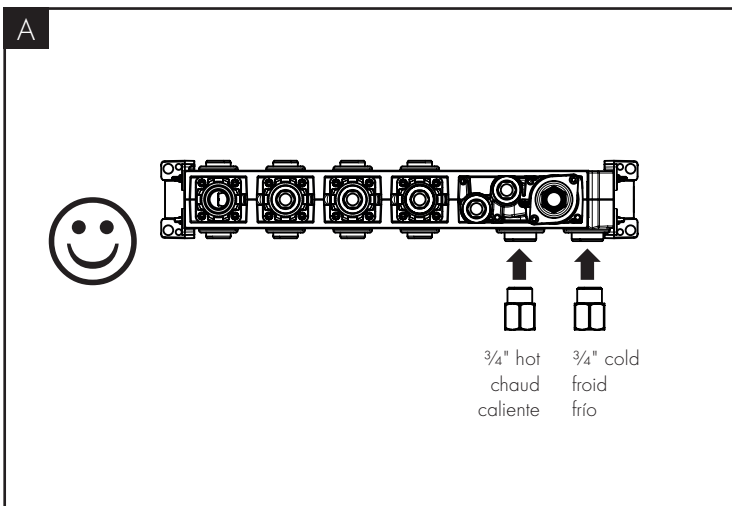

AXOR Select
18310181

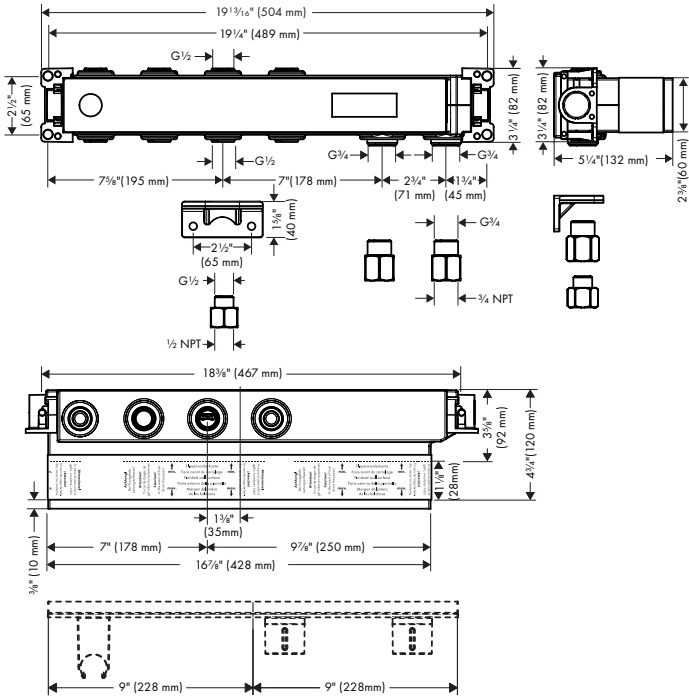

AXOR Select
18311181

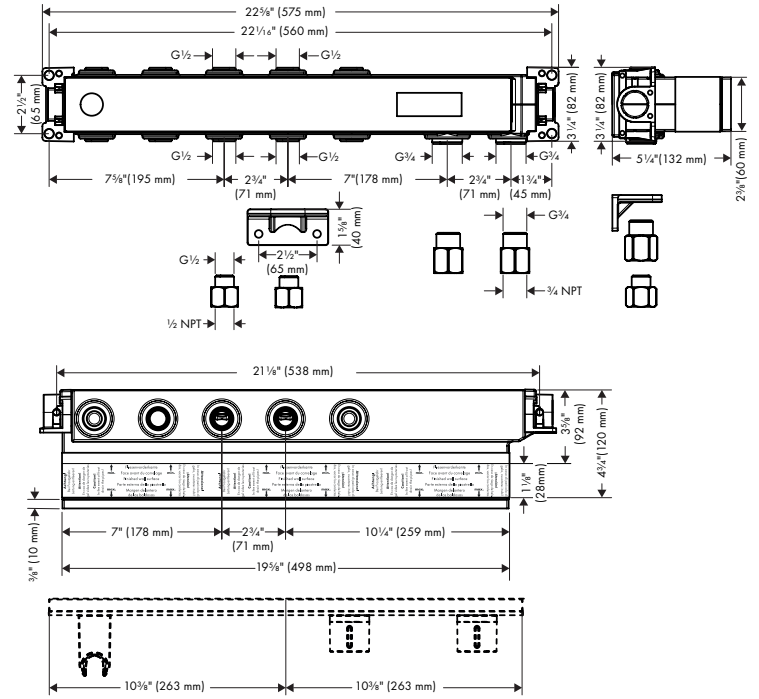

AXOR Select
18312181

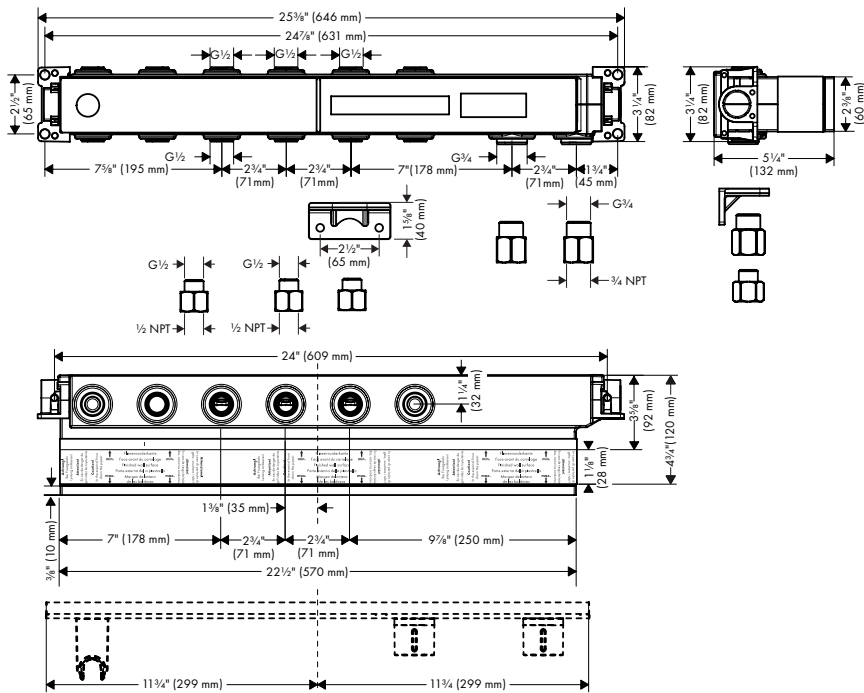

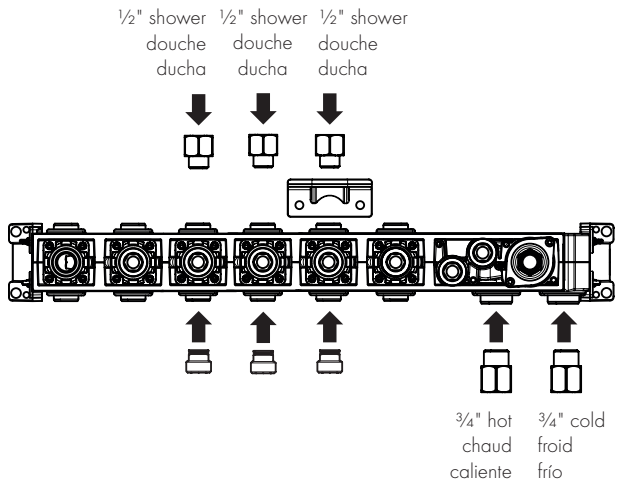
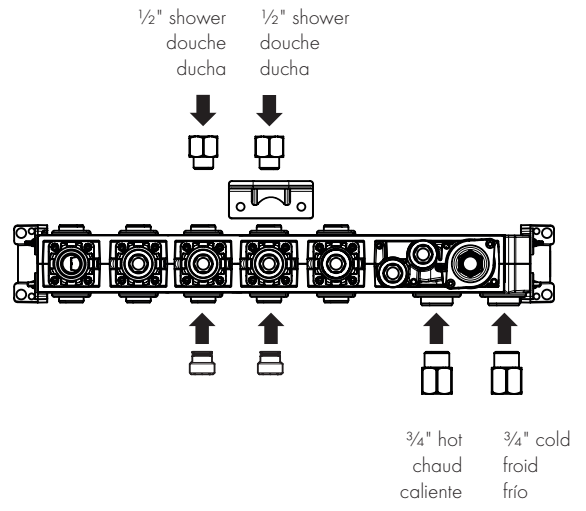
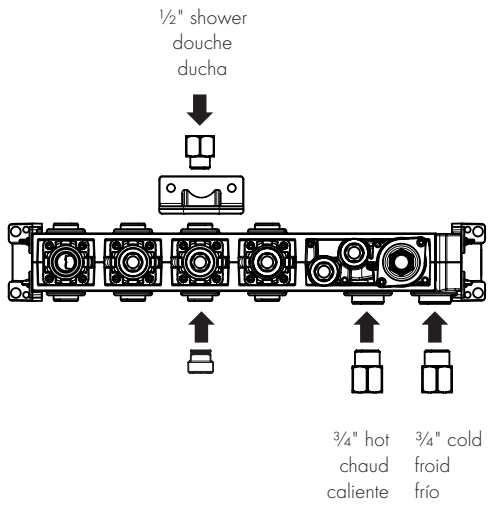

INSTALLATION SUGGESTIONS / SUGGESTIONS D'INSTALLATION / SUGERENCIAS PARA LA INSTALACIÓN

AXOR Select
18310181

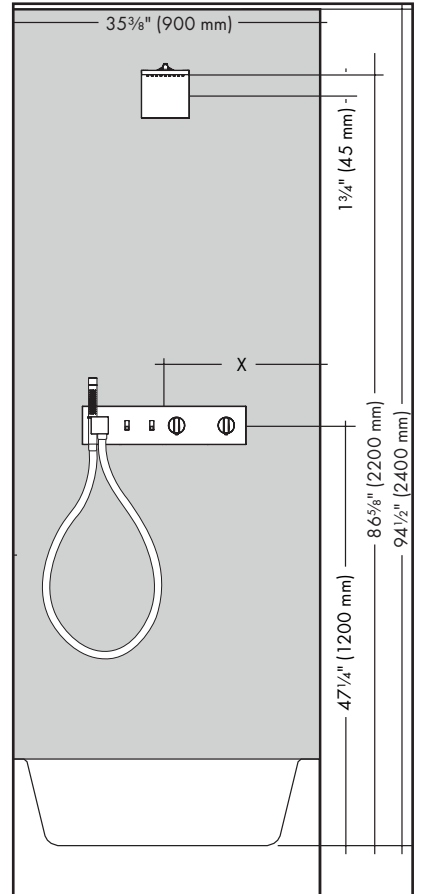
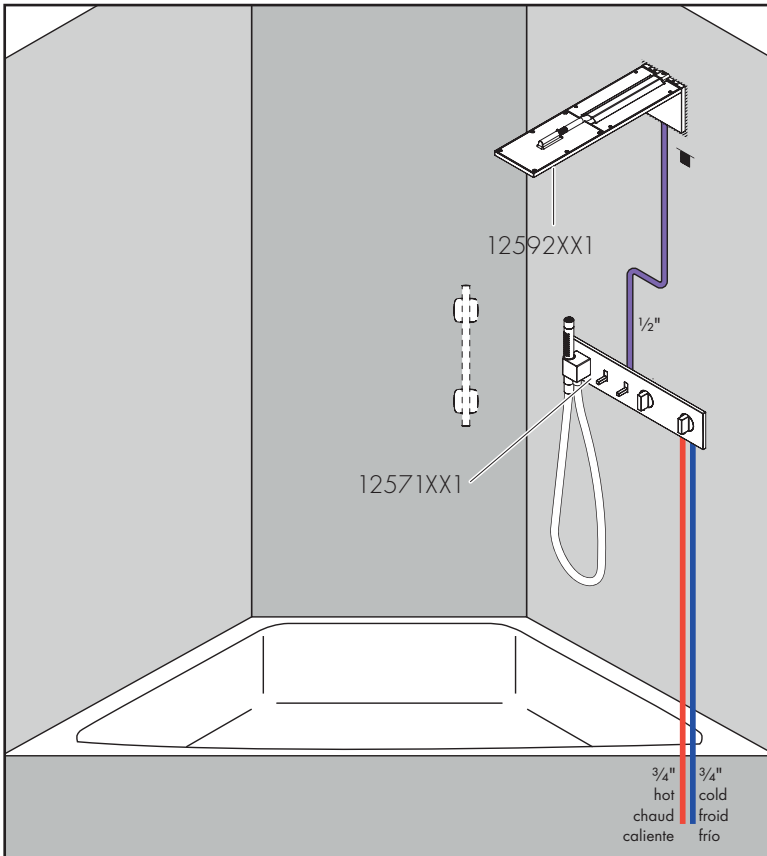
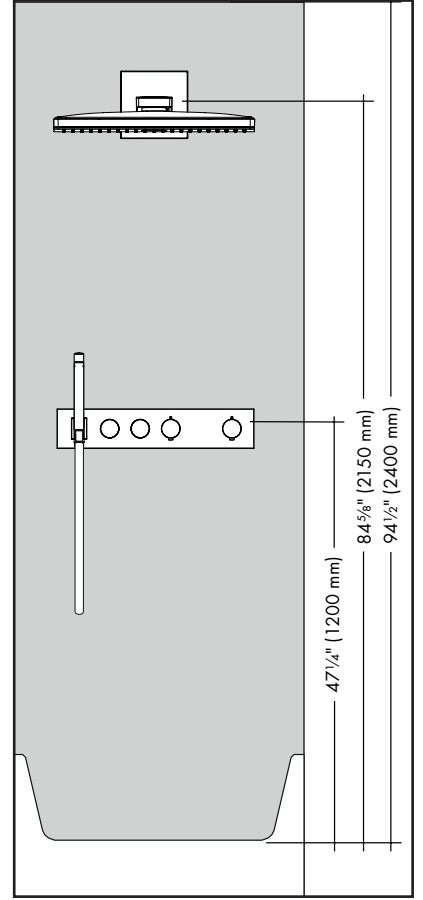
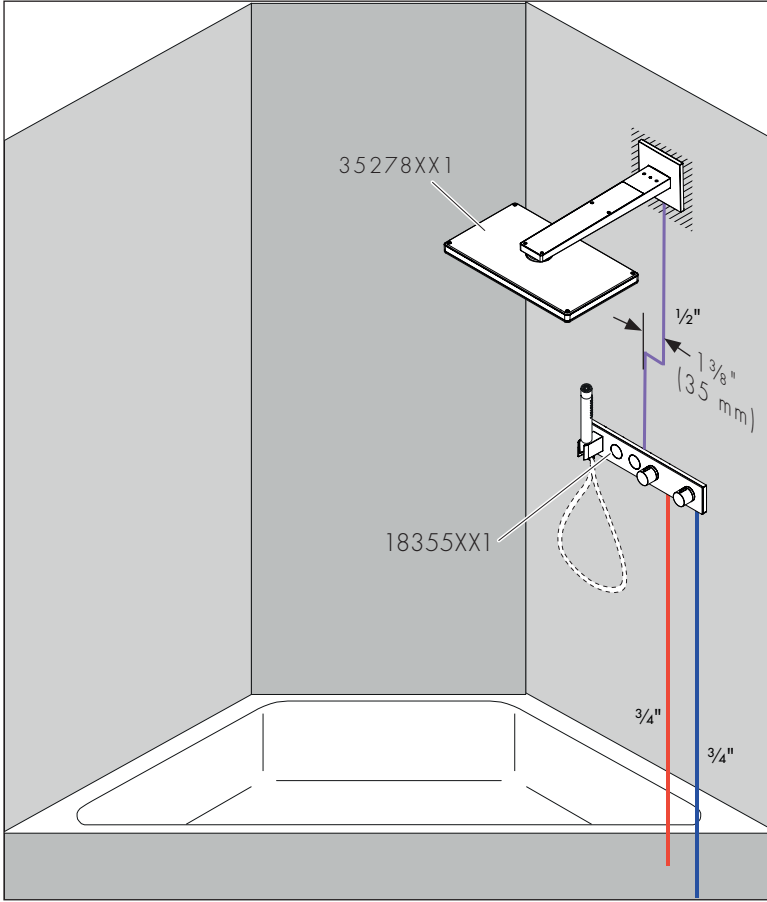

INSTALLATION SUGGESTIONS / SUGGESTIONS D'INSTALLATION / SUGERENCIAS PARA LA INSTALACIÓN

AXOR Select
18311181

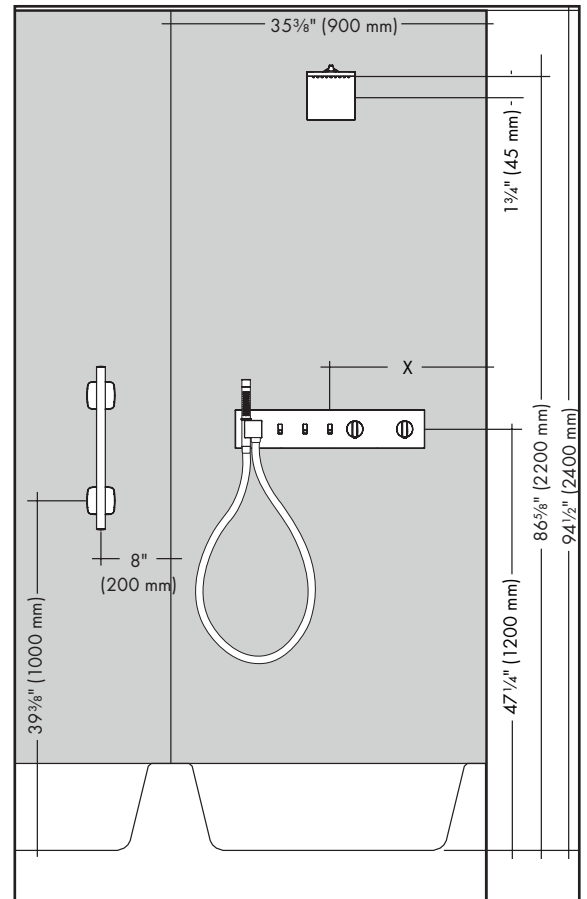
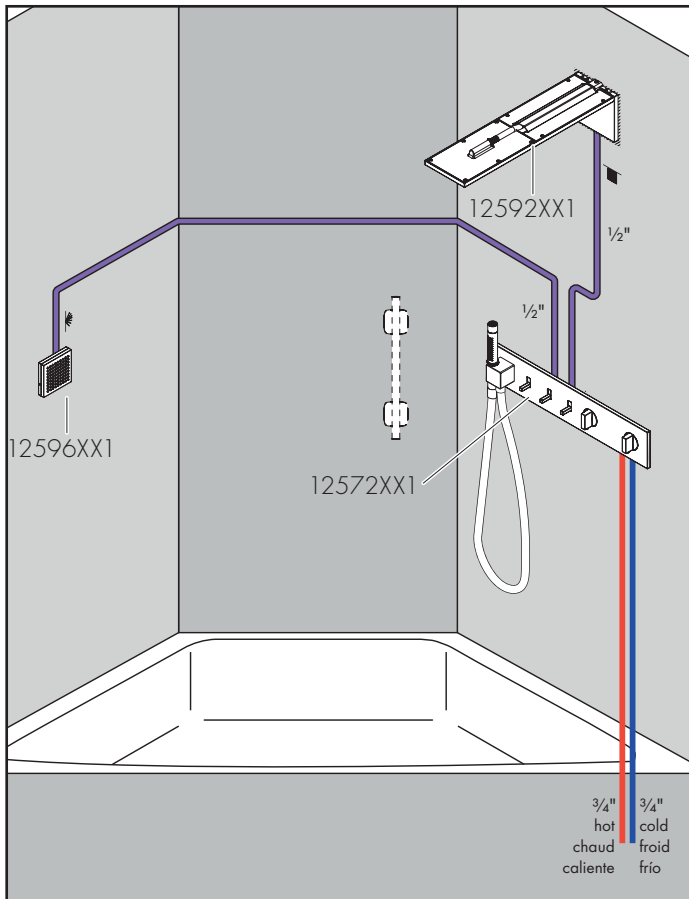
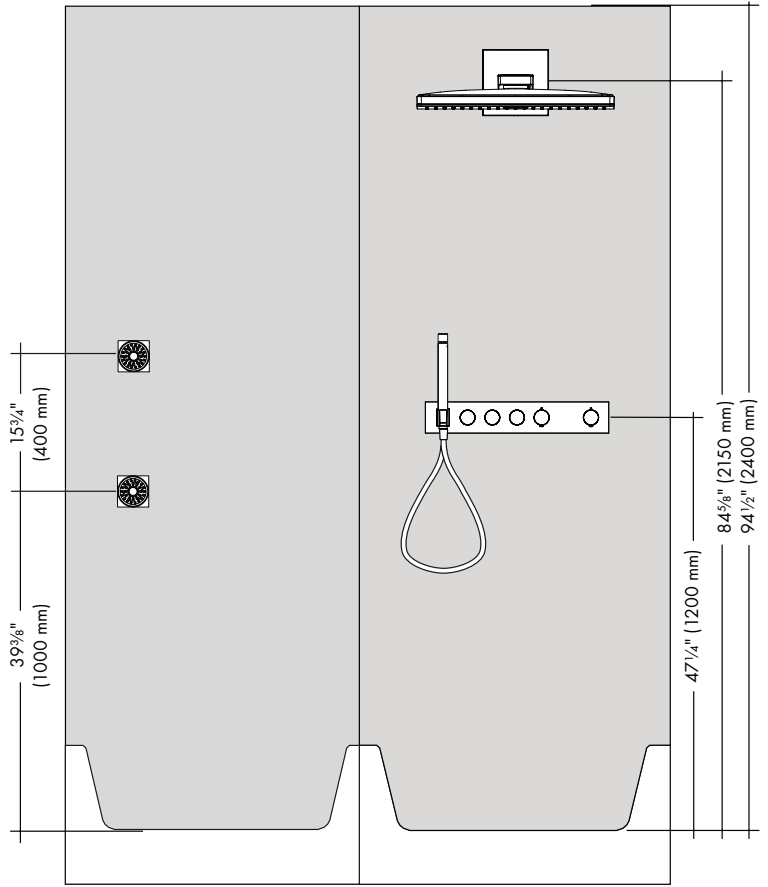
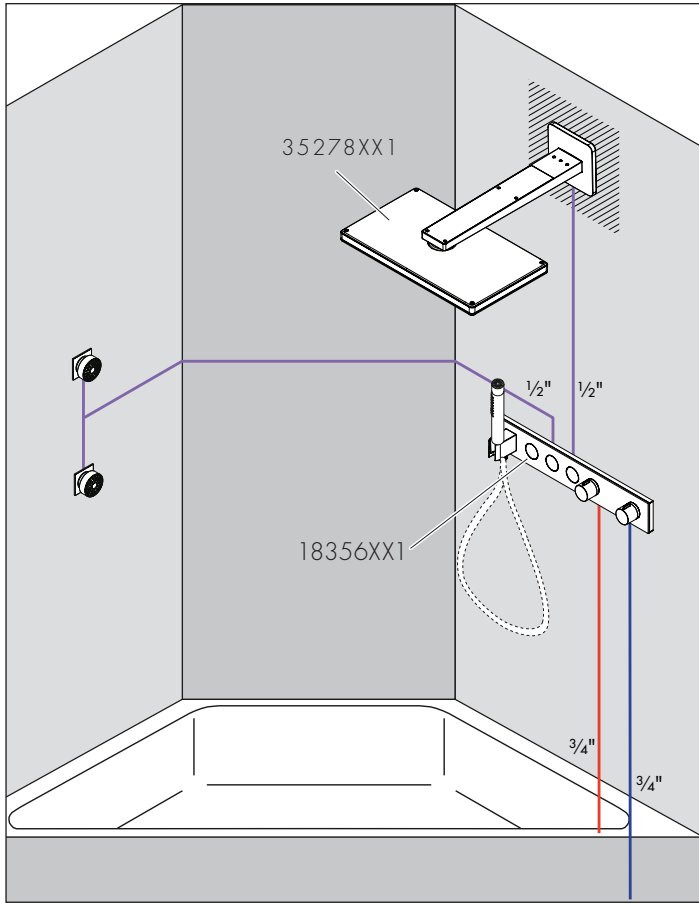

IMPORTANT: If this product is to be installed in a stud wall, modification of the wall is necessary. Follow all applicable local building codes and proper building practices when making such modification to ensure that the wall remains structurally sound.

IMPORTANT: Si ce produit doit être installé dans un mur à poteaux, il est nécessaire de modifier le mur. Dans ce cas, respectez tous les codes locaux en vigueur et les méthodes de construction adéquates pour vous assurer que la structure du mur reste intacte.

IMPORTANTE: Si este producto se instalará en una pared con clavija, será necesario modificar la pared. Cumpla con todos los códigos de construcción locales vigentes y las prácticas correctas de construcción al llevar a cabo dicha modificación para asegurarse de que la pared permanezca estructuralmente adecuada.

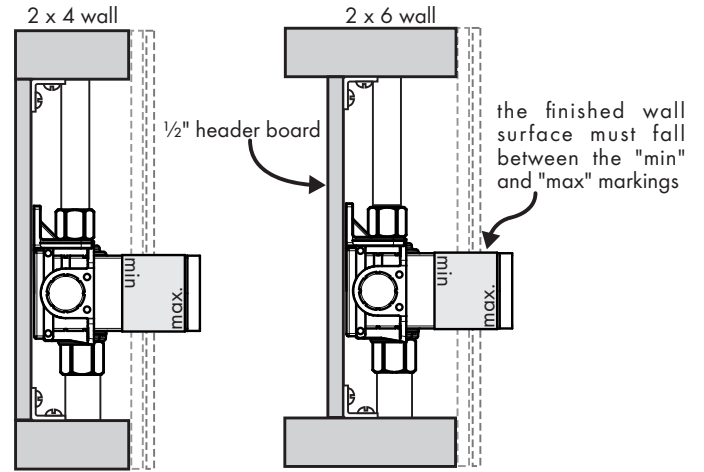

AXOR Select
18311181

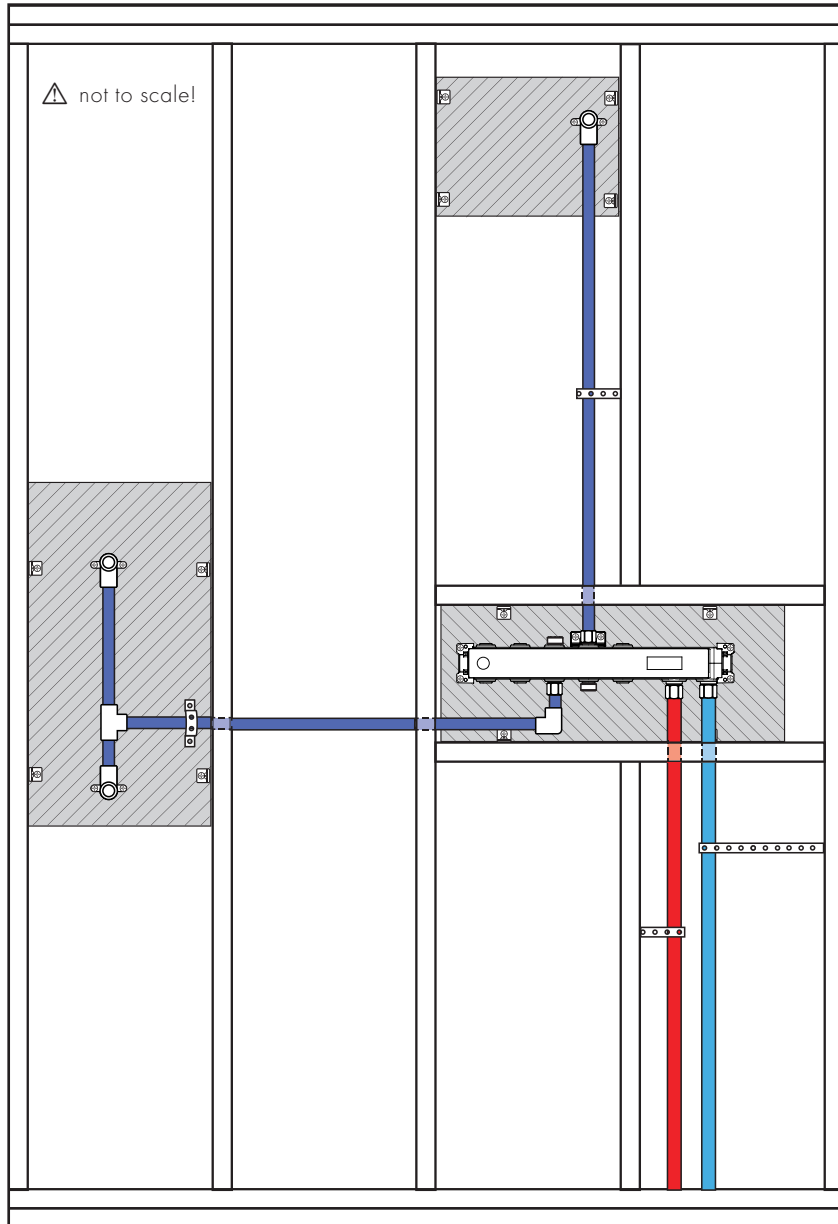

AXOR Select
18310181

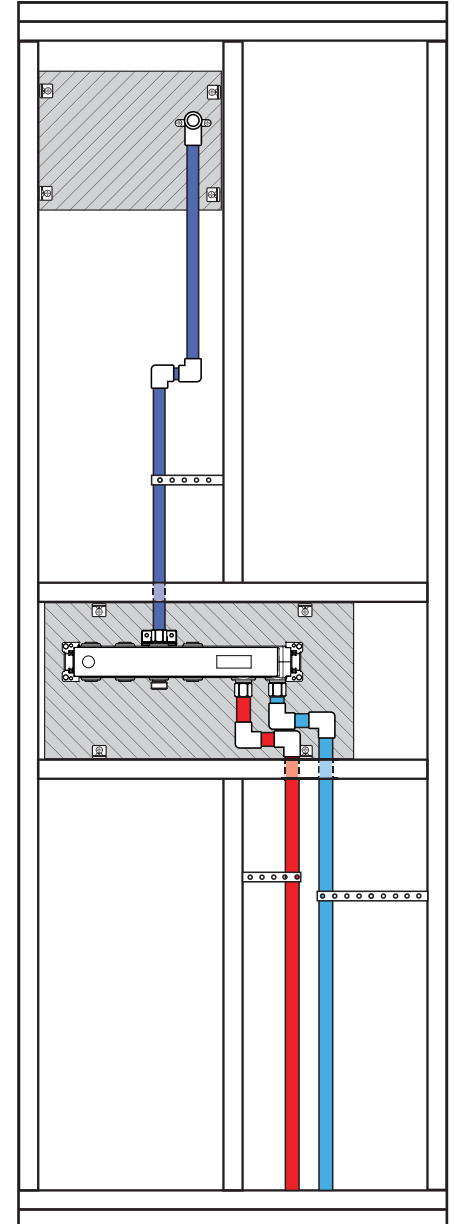

INSTALLATION / INSTALLATION / INSTALACIÓN

ENGLISH

FRANÇAIS

ESPAÑOL

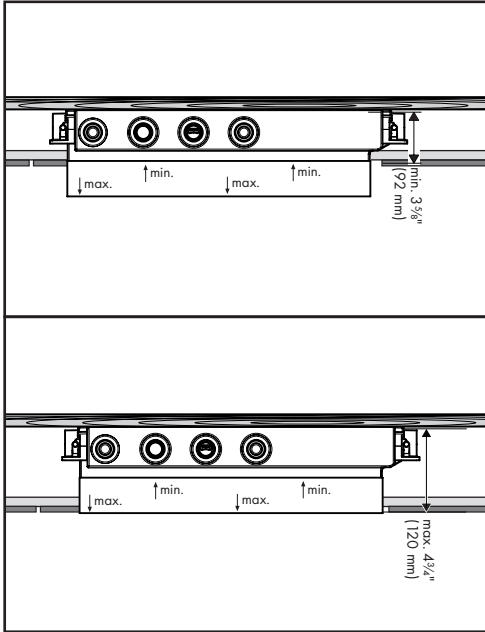

⚠ Install this valve so that the outside surface of the finished wall falls somewhere between the "min" and "max" markings on the installation box.

⚠ Installez ces vannes de façon à ce que la surface extérieure du mur fini se trouve entre les lignes « minimum » et « maximum » de la boîte d'installation.

⚠ Instale esta válvula de modo que la superficie exterior de la pared terminada quede entre las marcas "mín." y "máx." en la caja de instalación.

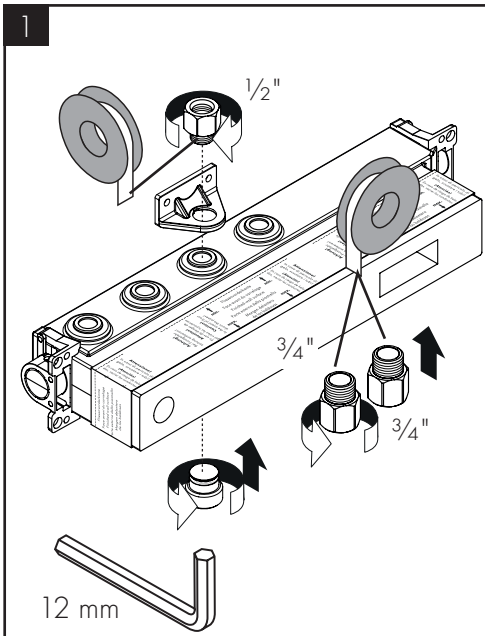

1 Wrap the threads on the 3/4" NPT adapters using plumber's thread tape. Install them on the hot and cold inlet ports.

Wrap the threads on the 1/2" NPT adapter(s) using plumber's thread tape. Install the adapter(s) on the outlet port(s).

Use one of the adapters to connect the support to the rough.

Wrap the threads on the plug(s). Install the plug(s) on the unused outlet port(s).

Enroulez les filets sur les adaptateurs NPT 3/4 po à l'aide de ruban de plomberie. Installez-les sur les ports d'alimentation d'eau chaude et froide.

Enroulez les filets sur le ou les adaptateurs NPT 1/2 po à l'aide de ruban de plomberie. Installez le ou les adaptateurs dans le ou les orifices de sortie.

Utilisez l'un des adaptateurs pour attacher le support à la pièce intérieure.

Enroulez les filets sur le ou les bouchons. Installez le ou les bouchons sur le ou les ports de sortie inutilisés.

Envuelva las rosas en los adaptadores NPT de 3/4" con cinta de plomero. Instálelas en los puertos de entrada de agua caliente y fría.

Envuelva las rosas en los adaptadores NPT de 1/2" con cinta de plomero. Instale los adaptadores en los puertos de salida.

Use uno de los adaptadores para conectar el soporte a la pieza interior.

Envuelva las rosas en el tapón. Instale los tapones en los puertos de salida no utilizados.

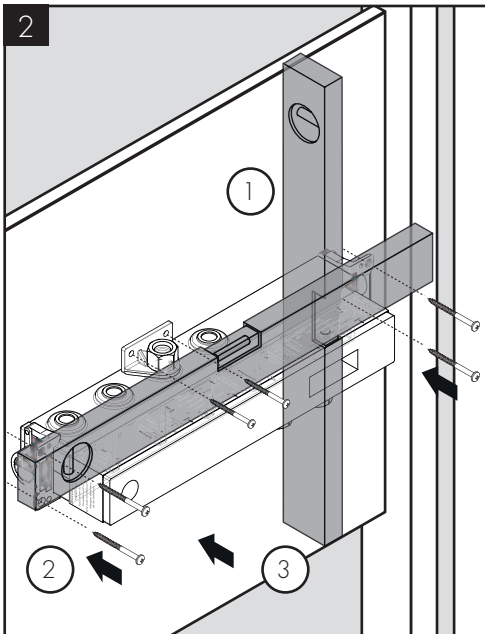

2 Screw the rough to the header board, making sure that it is level.

Vissez la pièce intérieure sur le panneau, en vous assurant qu'elle soit de niveau.

Atornille la pieza interior al panel de cabezal, asegurándose de que esté nivelado.

ENGLISH

FRANÇAIS

ESPAÑOL

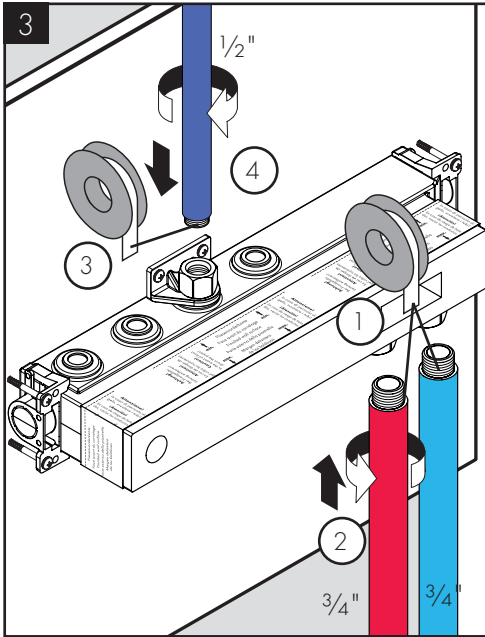

Install the 3/4" hot and cold supply lines.

Installez les conduites d'alimentation d'eau chaude et d'eau froide de 3/4 po.

Instale las tuberías de suministro de agua fría y caliente de 3/4".

⚠ To insure correct function of the thermostatic mixing valve, the hot must be on the left and the cold must be on the right.

⚠ Pour que le mitigeur thermostatique fonctionne correctement, la conduite d'alimentation de l'eau chaude doit être installée à gauche et la conduite d'eau froide doit être installée à droite.

⚠ Para garantizar que la válvula mezcladora termostática funcione correctamente, el suministro de agua caliente debe estar a la izquierda y el de agua fría a la derecha.

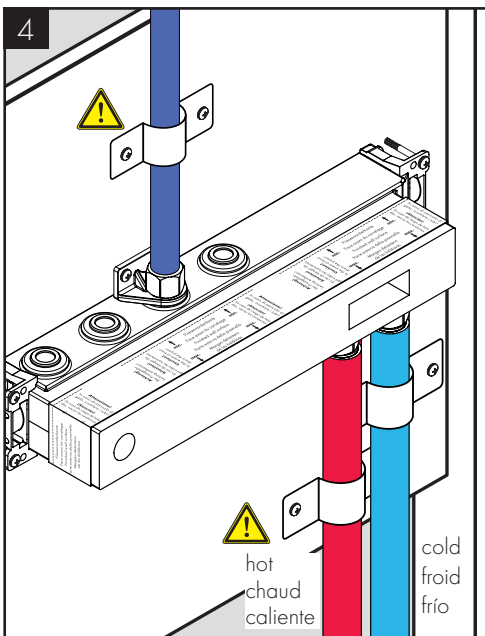

Make sure that the pipes are firmly secured.

Assurez-vous de bien fixer les conduites.

Asegúrese de que las tuberías estén firmemente sujetadas.

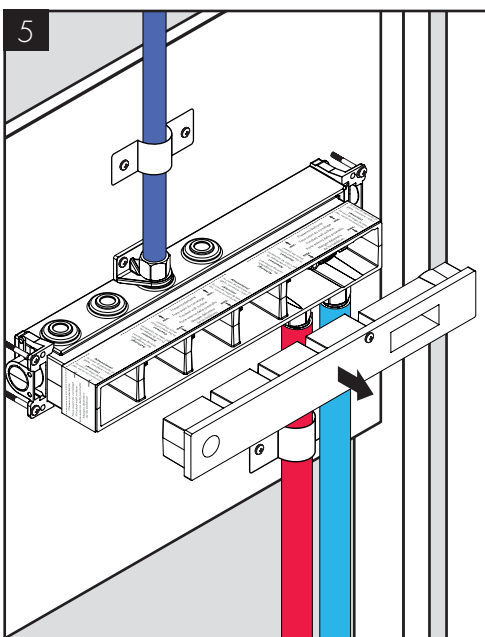

Remove the flush housing insert.

Retirez l'insert du compartiment affleurant.

Retire el inserto del alojamiento de descarga.

ENGLISH

FRANÇAIS

ESPAÑOL

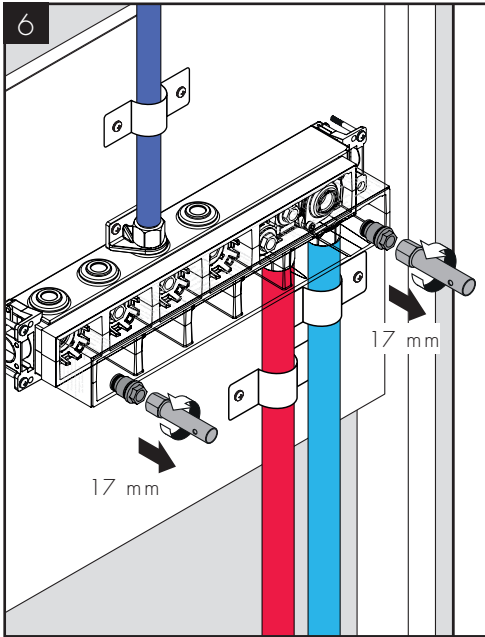

Remove the plugs from the thermostatic mixer housing and the handshower housing.

Retirez les bouchons du compartiment du mitigeur thermostatique et du compartiment de la douche.

Retire los tapones de la carcasa del mezclador termostático y de la carcasa de la ducha de mano.

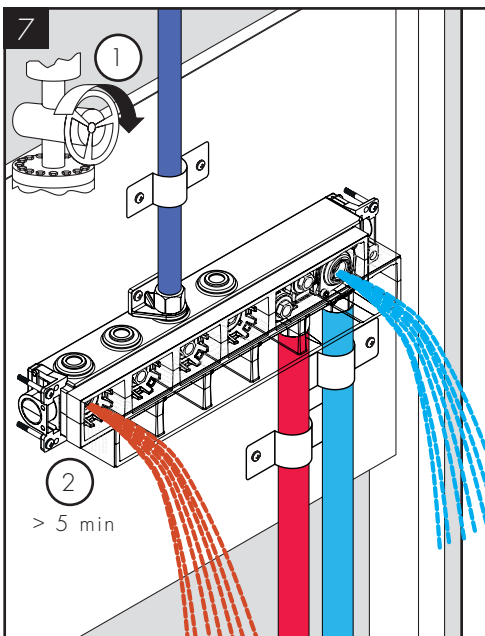

Turn the water on at the main.

Ouvrez l'eau à la valve principale.

Abra el paso del agua en la entrada del suministro.

Flush the hot and cold supplies for at least 5 minutes.

Rincez les conduites d'alimentation d'eau chaude et d'eau froide pendant au moins 5 minutes.

Purgue los suministros de agua caliente y agua fría durante al menos 5 minutos.

The cold supply will flush through the thermostatic mixer housing and the hot supply will flush through the handshower housing.

L'eau froide rincera le compartiment du mitigeur thermostatique tandis que l'eau chaude rincera le compartiment de la douche.

El suministro de agua fría se purga a través de la carcasa del mezclador termostático y el suministro de agua caliente mediante la carcasa de la ducha de mano.

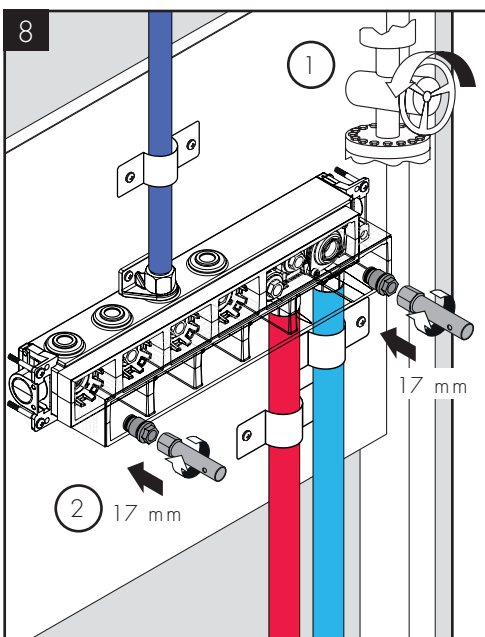

Turn the water off.

Fermez l'eau.

Cierre el suministro de agua.

Reinstall the plugs.

Réinstallez les bouchons.

Vuelva a instalar los tapones.

ENGLISH

FRANÇAIS

ESPAÑOL

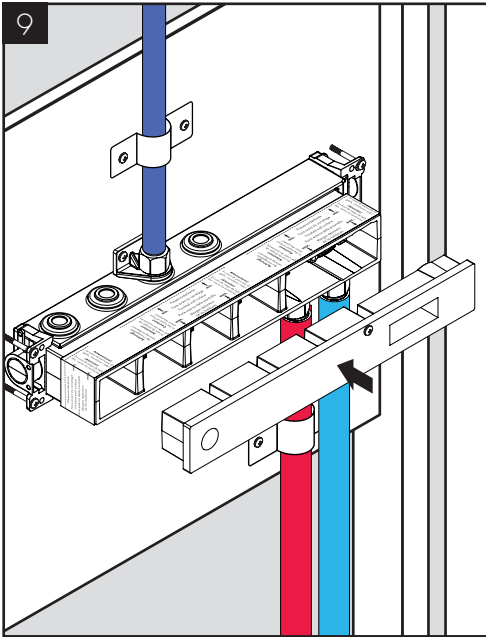

Install the insert.

Installez l'insert.

Instale el inserto.

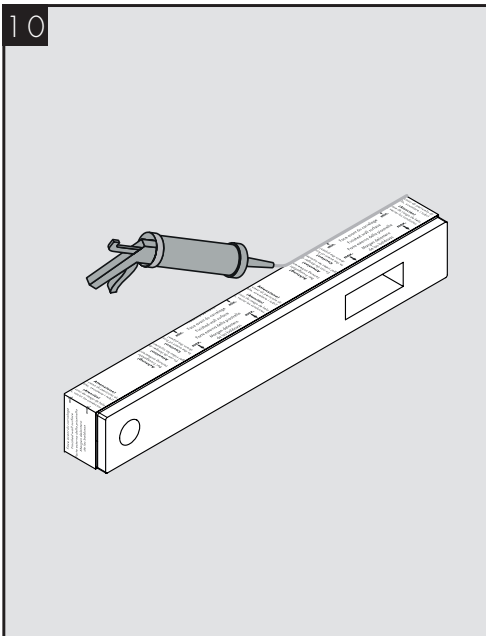

Install the sheetrock or green board up to the installation box.

Installez la plaque de plâtre ou la céramique jusqu'à la boîte d'installation.

Instale el estuco o panel verde hasta la caja de instalación.

Seal the wall around the installation box using waterproof sealant.

Scellez le mur autour du boîtier d'installation à l'aide d'un agent d'étanchéité.

Selle la pared alrededor de la caja de instalación con un sellador impermeable.

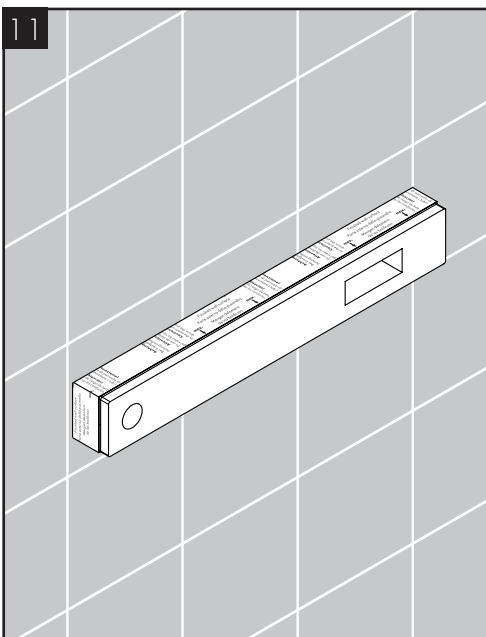

Install the finished wall surface up to the installation box.

Installez la surface finie du mur jusqu'à la boîte d'installation.

Instale la superficie de la pared terminada hasta la caja de instalación.

REPLACEMENT PARTS / PIÈCES DÉTACHÉES / REPUESTOS

AXOR Select

18310181

18311181

18312181

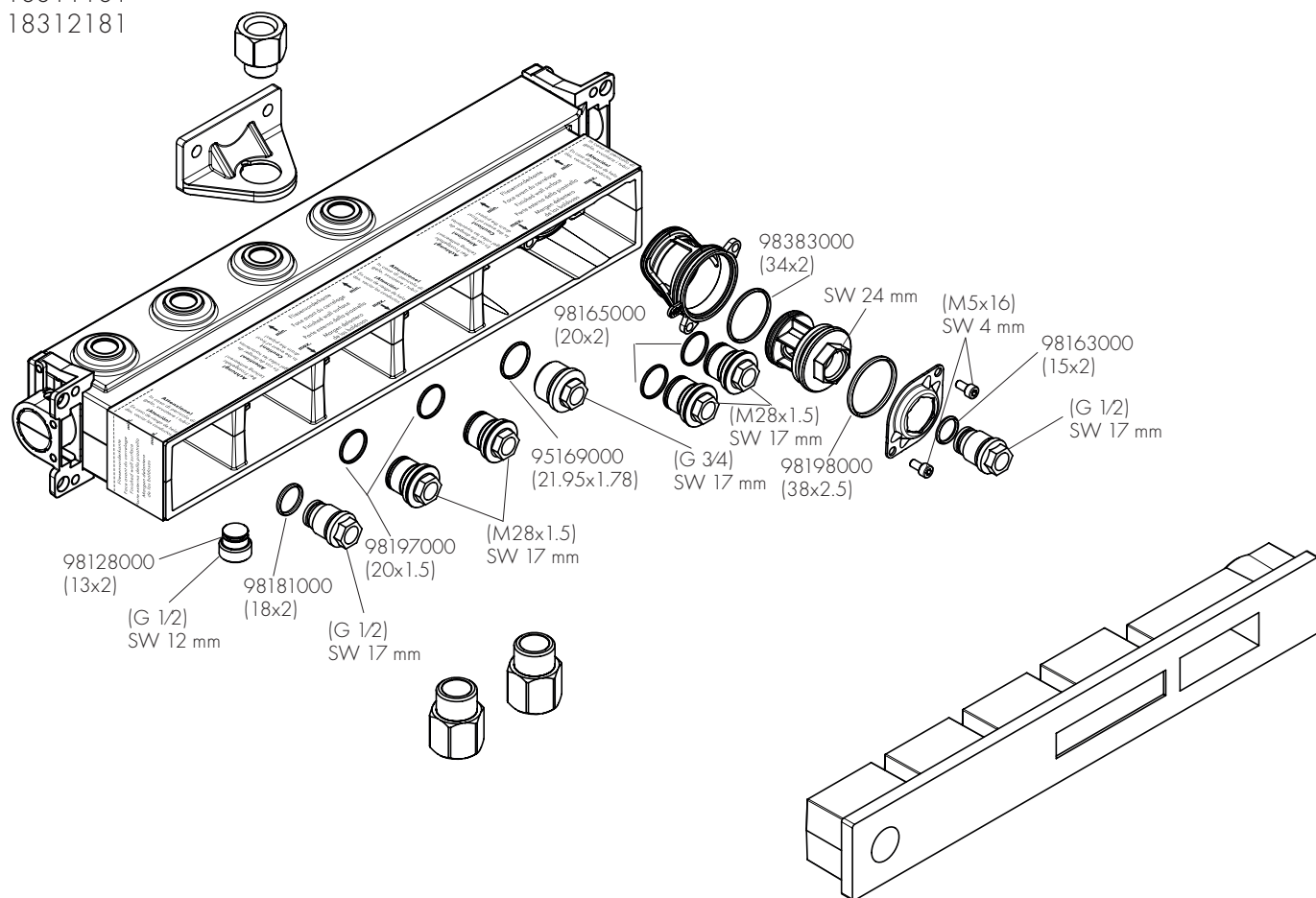

HANSGROHE, INC. LIMITED WARRANTY

Offering our customers the highest quality at all times is a fundamental part of the Hansgrohe, Inc. company philosophy. We offer consumers a limited warranty on our hansgrohe® and AXOR® branded products.

This warranty is limited to products manufactured by Hansgrohe, Inc. that are purchased from a Hansgrohe, Inc. authorized seller by a consumer in the United States or Canada after September 1, 2019, and installed in either the United States or in Canada.

WARRANTY

Hansgrohe, Inc. warrants to the original consumer purchaser that hansgrohe and AXOR products will be free from defects in material and workmanship for as long as the original consumer purchaser owns both the product and the home in which the product was originally installed. For commercial purchasers, the warranty period is (a) one (1) year for hansgrohe products and (b) five (5) years for AXOR products, in each case from the date of purchase. The warranty period for products in the Rubbed Bronze, Matte Black and Matte White finishes are three (3) years from the date of purchase. This warranty is non-transferable.

WHAT WE WILL DO

Hansgrohe, Inc., at its option, will replace any product or part of the product that proves defective in workmanship and/ or material, under normal installation, use, service and maintenance. If Hansgrohe, Inc. is unable to provide a replacement part or product and repair is not practical or cannot be made in timely fashion, Hansgrohe, Inc. may elect to refund the purchase price in exchange for the return of the defective product. REPAIR OR REPLACEMENT (OR, IN LIMITED CIRCUMSTANCES, REFUND OF THE PURCHASE PRICE) AS PROVIDED UNDER THIS LIMITED WARRANTY IS THE EXCLUSIVE REMEDY OF THE PURCHASER.

WHAT IS NOT COVERED BY THE WARRANTY

Because Hansgrohe, Inc. is unable to control the quality of hansgrohe or AXOR products sold by unauthorized sellers, unless otherwise prohibited by law, this warranty does not cover hansgrohe or AXOR products purchased from unauthorized sellers. Authorized sellers can be found on hansgrohe and AXOR branded websites.

Labor and other expenses for disconnection, deinstallation, or return of the product for warranty service (including but not limited to proper packaging and shipping costs), or for installation or reinstallation of the product are not covered by this warranty.

Hansgrohe, Inc. shall not be liable for any damage to the product resulting from

- reasonable wear and tear
- outdoor use
- misuse (including use of the product for an unintended application)
- freezing water
- excessive water pressure
- pipe corrosion in the home in which the product is installed
- abuse, neglect or improper or incorrectly performed installation, maintenance or repair, including the use of abrasive or caustic cleaning agents or "no-rinse" cleaning products.

This warranty does not cover: (i) accessories, connected materials and products, or related products not manufactured by Hansgrohe, Inc. (ii) any hansgrohe or AXOR product sold for display purposes or (iii) hansgrohe or AXOR products purchased from unauthorized sellers.

WHAT YOU MUST DO TO OBTAIN WARRANTY SERVICE OR INFORMATION

Contact your retailer, or contact Technical Service at:

Hansgrohe, Inc.
1492 Bluegrass Lakes Parkway
Alpharetta, GA 30004
Toll-free 800-334-0455

In requesting warranty service, you will need to provide:

1. The sales receipt or other evidence of the date and place of purchase.
2. A description of the problem.
3. Delivery of the product or the defective part, postage prepaid and carefully packed and insured, to:

Hansgrohe, Inc.
1492 Bluegrass Lakes Parkway
Alpharetta, GA 30004
Toll-free 800-334-0455

When warranty service is completed, any repaired or replacement product or part will be returned to you postage prepaid.

REVISED SEPTEMBER 1, 2019.

LIMITATION ON DURATION OF IMPLIED WARRANTIES: Some States do not allow limitations on how long an implied warranty lasts, so the below limitations may not apply to you. TO THE MAXIMUM EXTENT PERMITTED BY APPLICABLE LAW, ANY IMPLIED WARRANTY, INCLUDING THE IMPLIED WARRANTIES OF MERCHANTABILITY AND OF FITNESS FOR A PARTICULAR PURPOSE, IS LIMITED TO THE STATUTORY PERIOD OR THE DURATION OF THIS WARRANTY, WHICHEVER IS SHORTER.

LIMITATION OF SPECIAL, INCIDENTAL OR CONSEQUENTIAL DAMAGES: Some States do not allow the exclusion or limitation of incidental or consequential damages, so the below limitations and exclusions may not apply to you.

TO THE MAXIMUM EXTENT PERMITTED BY APPLICABLE LAW, THIS WARRANTY DOES NOT COVER, AND HANSGROHE, INC. SHALL NOT BE LIABLE FOR, ANY SPECIAL, INCIDENTAL OR CONSEQUENTIAL DAMAGES (INCLUDING LABOR CHARGES TO REPAIR, REPLACE, INSTALL OR REMOVE THIS PRODUCT), WHETHER ARISING OUT OF BREACH OF ANY EXPRESS OR IMPLIED WARRANTY, BREACH OF CONTRACT, TORT, OR OTHERWISE. HANSGROHE, INC. SHALL NOT BE LIABLE FOR ANY DAMAGE TO THE PRODUCT RESULTING FROM REASONABLE WEAR AND TEAR, OUTDOOR USE, MISUSE (INCLUDING USE OF THE PRODUCT FOR AN UNINTENDED APPLICATION), FREEZING WATER, EXCESSIVE WATER PRESSURE, PIPE CORROSION IN THE HOME IN WHICH THE PRODUCT IS INSTALLED, ABUSE, NEGLIGENCE OR IMPROPER OR INCORRECTLY PERFORMED INSTALLATION, MAINTENANCE OR REPAIR, INCLUDING THE USE OF ABRASIVE OR CAUSTIC CLEANING AGENTS OR "NO-RINSE" CLEANING PRODUCTS.

NOTICE TO RESIDENTS OF THE STATE OF NEW JERSEY: The provisions of this warranty, including its limitations, are intended to apply to the fullest extent permitted by the laws of the State of New Jersey.

This warranty gives you specific legal rights, and you may also have other rights which vary from state to state.

PRODUCT INSTRUCTIONS AND QUESTIONS

Upon purchase or prior to installation, please carefully inspect your product for any damage or visible defect. Prior to installing, always carefully study the enclosed instructions on the proper installation and the care and maintenance of this product.

If you have questions at any time about the use, installation or performance of your product, or the Limited Warranty, please write us or call us toll-free at 800-334-0455.

AXOR

AXOR / Hansgrohe, Inc.
1490 Bluegrass Lakes Parkway
Alpharetta, GA 30004

Tel. 800-334-0455
Fax 770-889-1783

axor-design.com