

PRODUCT SPECIFICATIONS

Stainless Steel Access Panel for Single Architectural Fountains.
Overall dimensions are 19-3/4" x 5/8" x 12".

A Century of Tradition and Quality.
For more than 100 years, Elkay has been making innovative products and providing exceptional customer care. We take pride in offering plumbing products that make life easier, inspire change and leave the world a better place.

Finish:	Stainless Steel (S)
Dimensions:	19-3/4" x 5/8" x 12"
Shipping Weight:	5 lbs.

Special Note: ACCESS12X19-75 can be installed above or below Single Architectural Fountains and Single Architectural Fountains with Integral Bottle Fillers.

- 12" high X 19-3/4" wide
- Allows easy access for servicing
- Stainless steel access panel for single architectural fountains and single architectural fountains with integral bottle fillers

PART: _____ QTY: _____

PROJECT: _____

CONTACT: _____

DATE: _____

NOTES: _____

APPROVAL:

In keeping with our policy of continuing product improvement, Elkay reserves the right to change product specifications without notice. Please visit elkay.com for the most current version of Elkay product specification sheets. This specification describes an Elkay product with design, quality, and functional benefits to the user. When making a comparison of other producers' offerings, be certain these features are not overlooked.

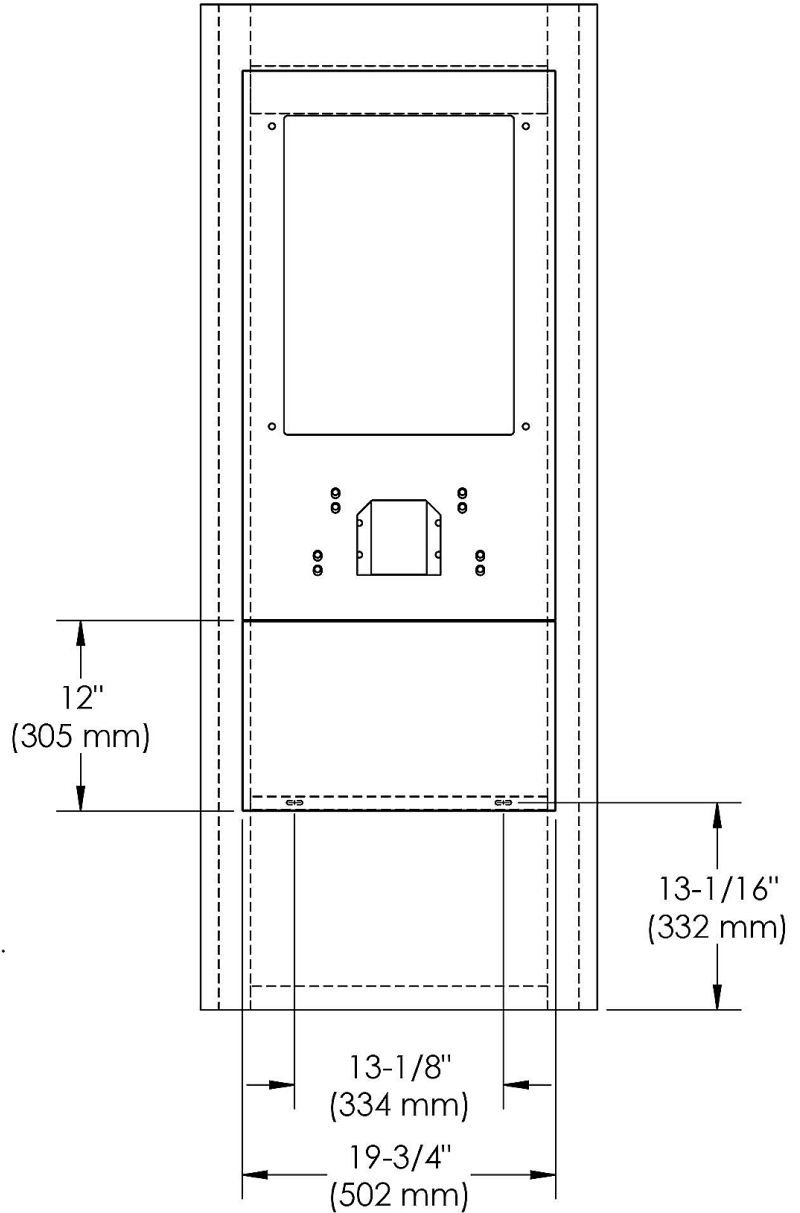
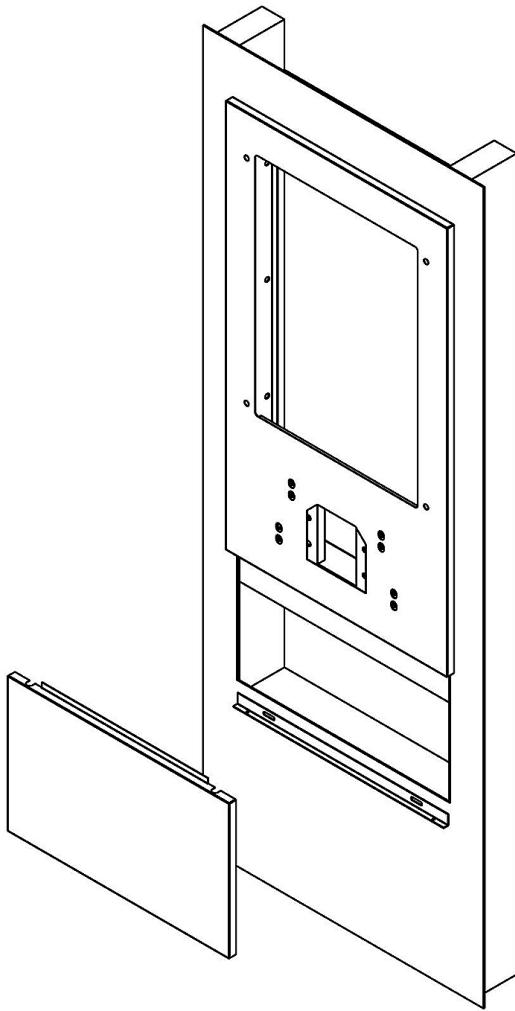

Includes the access panel and L-bracket for mounting. The access panel has a tab along the top which secures behind the fountain back panel. L-bracket is mounted to the wall. Access panel is secured to L-bracket with screws.

Note - upper panel portion is not included with this item. Shown only for mounting reference.

In keeping with our policy of continuing product improvement, Elkay reserves the right to change product specifications without notice. Please visit elkay.com for the most current version of Elkay product specification sheets. This specification describes an Elkay product with design, quality, and functional benefits to the user. When making a comparison of other producers' offerings, be certain these features are not overlooked.