

PRODUCT SPECIFICATIONS

Stainless Steel 16-3/4" x 15-1/2" x 13" Single Bowl Wall Hung Handwash Sink Kit. Sink is manufactured from 20 gauge 304 Stainless Steel with a Buffed Satin finish, Center drain placement.



Material:	304 Stainless Steel
Finish:	Buffed Satin
Gauge:	20
Number of Bowls:	1
Sink Dimensions:	16-3/4" x 15-1/2" x 48-7/8"
Bowl 1 Dimensions:	12" x 9-1/4" x 6"
Drain Size:	1-1/2" (38mm)
Drain Location:	Center

Special Note: Side Splashes

Included with Product: CHSP1716 sink, LKB722C sensor faucet with AC plug-in/4 AA batteries, one LK723 thermostatic mixing valve, one LK8 grid drain fitting, one LK500 P-trap

▼ Ships in multiple boxes.

A Century of Tradition and Quality. For more than 100 years, Elkay has been making innovative products and providing exceptional customer care. We take pride in offering plumbing products that make life easier, inspire change and leave the world a better place.



Product Compliance: ASME A112.19.3/CSA B45.4
NSF 2
Faucet: ASME A112.18.1/CSA B125.1
CEC
NSF 372 (lead free)
NSF 61 (Q≤1)
Accessory: ASME A112.18.2/CSA B125.2



Sinks are listed by IAPMO® as meeting the applicable requirements of the Uniform Plumbing Code®, International Plumbing Code®, and National Plumbing Code of Canada.

- [Clean and Care Manual \(PDF\)](#)
- [Installation Instructions \(PDF\) - 98517C](#)
- [Installation Instructions \(PDF\) - LK723 Instruction Manual](#)
- [Installation Instructions \(PDF\) - 1000005235](#)
- [Installation Instructions \(PDF\) - 2000000714](#)
- [Warranty \(PDF\)](#)

PART: _____ QTY: _____
 PROJECT: _____
 CONTACT: _____
 DATE: _____
 NOTES: _____
 APPROVAL: _____

In keeping with our policy of continuing product improvement, Elkay reserves the right to change product specifications without notice. Please visit elkay.com for the most current version of Elkay product specification sheets. This specification describes an Elkay product with design, quality, and functional benefits to the user. When making a comparison of other producers' offerings, be certain these features are not overlooked.

Included Accessories

<p>LKB722C</p>	<p>Commercial Electronic Sensor Scrub/Handwash Battery Powered Wall Mount Faucet Chrome</p> <p>Spec Sheet (PDF)</p>	
--------------------------------	---	---

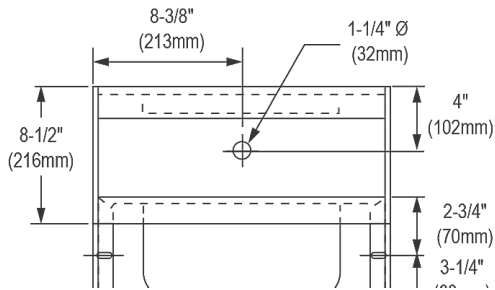
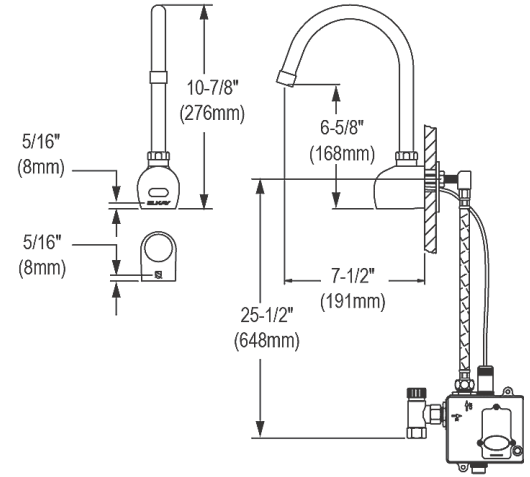
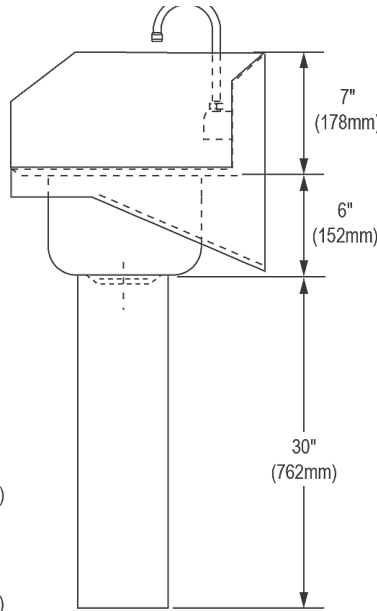
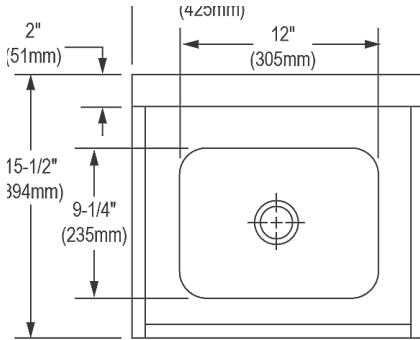

In keeping with our policy of continuing product improvement, Elkay reserves the right to change product specifications without notice. Please visit elkay.com for the most current version of Elkay product specification sheets. This specification describes an Elkay product with design, quality, and functional benefits to the user. When making a comparison of other producers' offerings, be certain these features are not overlooked.

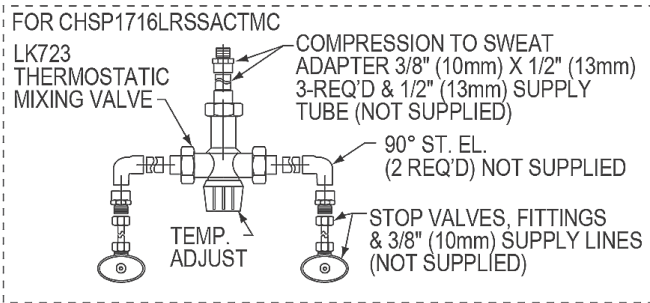
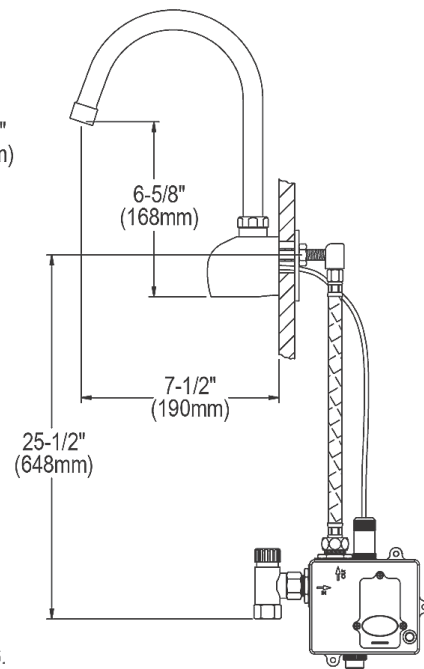
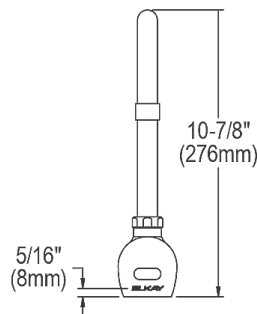
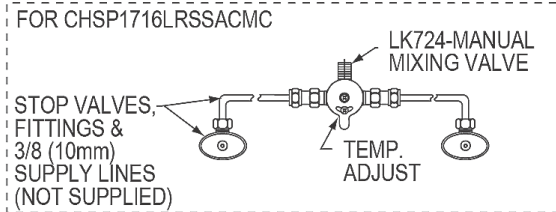
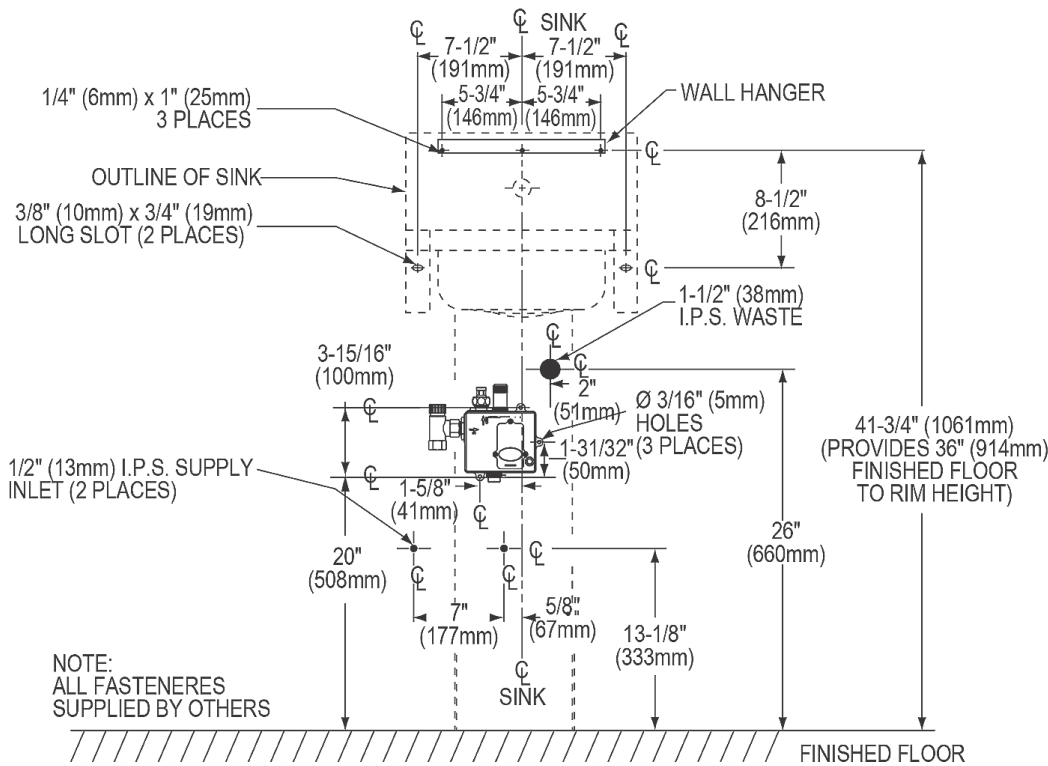

NOTE:
USE TEFLON TAPE FOR
ALL WATER CONNECTIONS.
DO NOT USE PIPE DOPE.

In keeping with our policy of continuing product improvement, Elkay reserves the right to change product specifications without notice. Please visit elkay.com for the most current version of Elkay product specification sheets. This specification describes an Elkay product with design, quality, and functional benefits to the user. When making a comparison of other producers' offerings, be certain these features are not overlooked.