

# ELKAY®

## Elkay EZH20 Refrigerated Floor Standing Bottle Filling Station, Filtered



### Pre-installation steps for Connected models only

#### Install Zurn Gateway and Register Product in plumbSMART

1. Install Zurn Gateway (required and sold separately) per the gateway instructions manual, if an existing gateway is not within communication range.
2. Be sure the gateway is powered on and connected (per gateway installation instructions) prior to installing your bottle filler. Serial number located on back of the Gateway, is required to register the gateway to your tenant
3. If you have not already set up an tenant account and your administrator access, request at 844-987-6737 or [zurnconnectedproducts@zurn.com](mailto:zurnconnectedproducts@zurn.com)
4. Log into [plumbsmart.zurn.com](http://plumbsmart.zurn.com)
5. Register Connected product in plumbSMART using plumbSMART Registration ID located on plumbSMART ID Registration Label, (see Fig. 4, pg. 14). (Watch How-To videos to get started. Located in the support section inside the portal.)

## INSTALLATION MANUAL

Patent [zurn-elkay.com/patents](http://zurn-elkay.com/patents)

⚠ **WARNING:** Cancer and Reproductive Harm - [www.P65Warnings.ca.gov](http://www.P65Warnings.ca.gov)

⚠ **ADVERTENCIA:** Cáncer y daño reproductivo - [www.P65Warnings.ca.gov](http://www.P65Warnings.ca.gov)

⚠ **AVERTISSEMENT:** Cancer et effets néfastes sur la reproduction - [www.P65Warnings.ca.gov](http://www.P65Warnings.ca.gov)

## 1. General Information

### 1.1 Installation Manual

Read all instructions carefully BEFORE starting the installation. and familiarize yourself with the various parts of this product.

This manual contains step-by-step installation, instructions for the DSSBF8S series bottle filling stations. Followed carefully, these instructions will result in troublefree installation of this Elkay Manufacturing Company (Elkay) product.

Any deviations, additions, and/or deletions from the described methods, without prior written approval of Elkay, will void the warranty covering this product.

Make sure the installation and use of this product meets all local, state, and federal plumbing and electrical codes

### Save these instructions for future reference

#### **⚠ WARNING**



**To avoid product or property damage, personal injury, or even possible death, carefully read, understand, and follow all the instructions in this Installation & Use Manual before installing his product.**

**Improper installation of this product could cause a dangerous situation that results in injury or death.**

**Do not operate power tools unless you read and understand the instructions and warnings in this and all other applicable labels or manuals. Proper use of tools and the products described in this guide is your responsibility.**

**Failure to follow these instructions could result in personal injuries, water damage, and other damage to floors, pipes, walls, and other portions of your building or home.**

### 1.2 Disclaimer

The information contained in this Installation & Use Manual is given free of charge. It is based upon technical data which we believe to be reliable and is intended for use by persons having knowledge of this technical area at their own discretion and risk. Elkay assumes no responsibility for results obtained or damage incurred from the use of this material either in whole or in part by the buyer.

### 1.3 Serial Number Location

Please use the serial number located on the underside of the water cooler when contacting us with questions concerning the installation of this product.

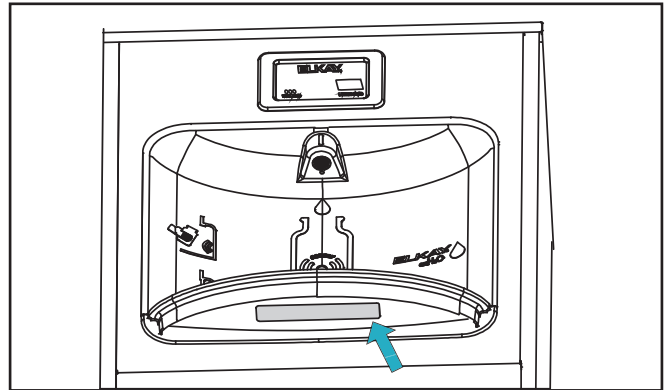

### 1.4 Contact Information

#### General Information

Elkay Manufacturing Company  
1333 Butterfield Road  
Suite 200 Downers Grove, IL 60515

Phone: 630.574.8484

Email: [consumer@elkay.com](mailto:consumer@elkay.com)

Website: <http://www.elkay.com>

#### USA/Canada Customer Care

Phone: 800.476.4106

Email: [CustCare@Elkay.com](mailto:CustCare@Elkay.com)

#### International Customer Care

Phone: 630.575.4755

Email: [IntlCare@Elkay.com](mailto:IntlCare@Elkay.com)

#### Installation Services

Phone: 800.952.8064

Email: [installservice@elkay.com](mailto:installservice@elkay.com)

Website: <http://www.elkay.com/contact-us/install>

### 1.5 Notice of Changes

The information, specifications, and illustrations in this manual are based on the information that was available at the time this material was written and can change at any time. In keeping with our policy of continuing product improvement, Elkay reserves the right to change specification without notice.

All dimensions are given in inches (") and millimeters (mm).

## 1.6 Warranty

This product is covered by a Limited Warranty and Elkay will not be held responsible for damage of any kind in connection with the installation of the product.

Refer to the Elkay website <http://www.elkay.com/warranty> and click on drinking water products, 'Warranty for Drinking Water Products' article under the Info and Maintenance section (form 96993C).

## 2. Safety



# Think Safety

**Before performing any work, read and understand the safety instructions in this manual.**

### 2.1 General

The Elkay Manufacturing Company (Elkay) cannot anticipate every possible circumstance that might involve a potential hazard during the installation or maintenance of this product. The warnings and instructions in this Installation Manual are, therefore, not all-inclusive. If a tool, installation procedure, or work method that is not specifically recommended by Elkay is used, you must be satisfied that it is safe for yourself and others. You should also make sure that the product will not be damaged by the methods you choose.

Most work related accidents are caused by failure to observe basic safety rules or precautions. An accident can often be avoided by recognizing potentially hazardous situations before an accident occurs. As you install and maintain this product, you must be alert to potential hazards. You should also have the necessary training, skills, and tools to perform any installation or maintenance procedure.

### 2.2 Safety Alert Symbol



This is the safety alert symbol. It is used to alert you to potential personal injury hazards. Obey all safety messages that follow this symbol to avoid possible injury or death.

This manual contains WARNINGS, CAUTIONS, NOTICES, SAFETY INSTRUCTIONS, and NOTES which must be followed to prevent the possibility of improper service, damage to the equipment, personal injury, or death. The following key words call the reader's attention to potential hazards.

Hazards are identified by the "Safety Alert Symbol" and followed by a signal word such as "WARNING" or "CAUTION".

2.3 Personal Safety

**⚠ WARNING**

These warnings indicate a potentially hazardous situation which, if not avoided, could result in serious injury or death. Follow all instructions related to the installation and/or maintenance of this product (unit).



**Personal Protection**

Be sure to use all personal protective equipment, such as sturdy safety glasses, work shoes, hearing protection, and cut resistant gloves, whenever necessary, to ensure your own safety.



To avoid eye injury, always wear protective glasses with side shields when using power tools. Also, make sure no one else can be injured by flying particles when using power tools.



To prevent possible damage to your hearing, always wear ear protection, such as earmuffs or earplugs, when using power tools.



This product is heavy and can cause bodily injury, due to its weight or if the unit is dropped. Use two people to lift the product when unpacking the unit or installing it onto the hanger brackets.



Wear protective gloves during installation to protect against sharp edges from sheet metal components.



**Lifting Hazard**

- To avoid personal injury, always use these proper lifting techniques and use two people to move heavy cartons.
- Use appropriate lifting devices to move the load.
- Always use two people when lifting heavy or bulky cartons. DO NOT attempt to lift objects that are too heavy.



**Power Tool Hazard**

To prevent personal injury or possible death, always follow the electrical safety recommendations of the power tool's manufacturer.

- Do not use power tools in an unsafe manner.
- Power tools should only be connected to a circuit protected by a ground-fault circuit interrupter (GFCI).
- If an extension cord is required, always use an OSHA approved extension cord.



**Shock and Electrocution Hazards**

Failure to follow these instructions could result in severe burns, significant injuries, and even death.



Water will conduct electric current to create a short circuit, resulting in injury or death.

- Never use electric power tools around water or wet floors/surfaces.
- Keep all liquids away from electrical cords and power tools.
- If an extension cord is required, always use an OSHA approved cord.
- DO NOT create a short circuit between a source of electricity and a liquid by being in contact with both simultaneously.



Contacting live electrical wiring with power tools or hand tools can cause serious injury or death.

- Make sure all related circuit breakers are turned OFF.
- Test for live circuits or wiring inside any wall where installation of the product requires cutting into a wall.



Prior to any maintenance, make sure the unit is unplugged and circuit breakers are turned OFF.



Prior to installation, test for live circuits or wiring inside the wall before cutting or drilling into the wall.

**⚠ CAUTION**

These cautions indicates a potentially hazardous situation which, if not avoided, may result in minor or moderate injury. Follow all instructions related to installation and/or maintenance of this product.



**Tripping Hazard**

Personal injury can result from tripping over power cords, tools, or other installation items. DO NOT leave items laying around the work area.



**Cutting Hazard**

The installation of this product may require using power tools.

Keep hands away from the cutting edge of any tool used in the installation of our product.

Placing fingers in or around the cutting blades could result in serious personal injury.

**DSSBF8SP , DSSBF8SP-W1 ROUGH-IN**

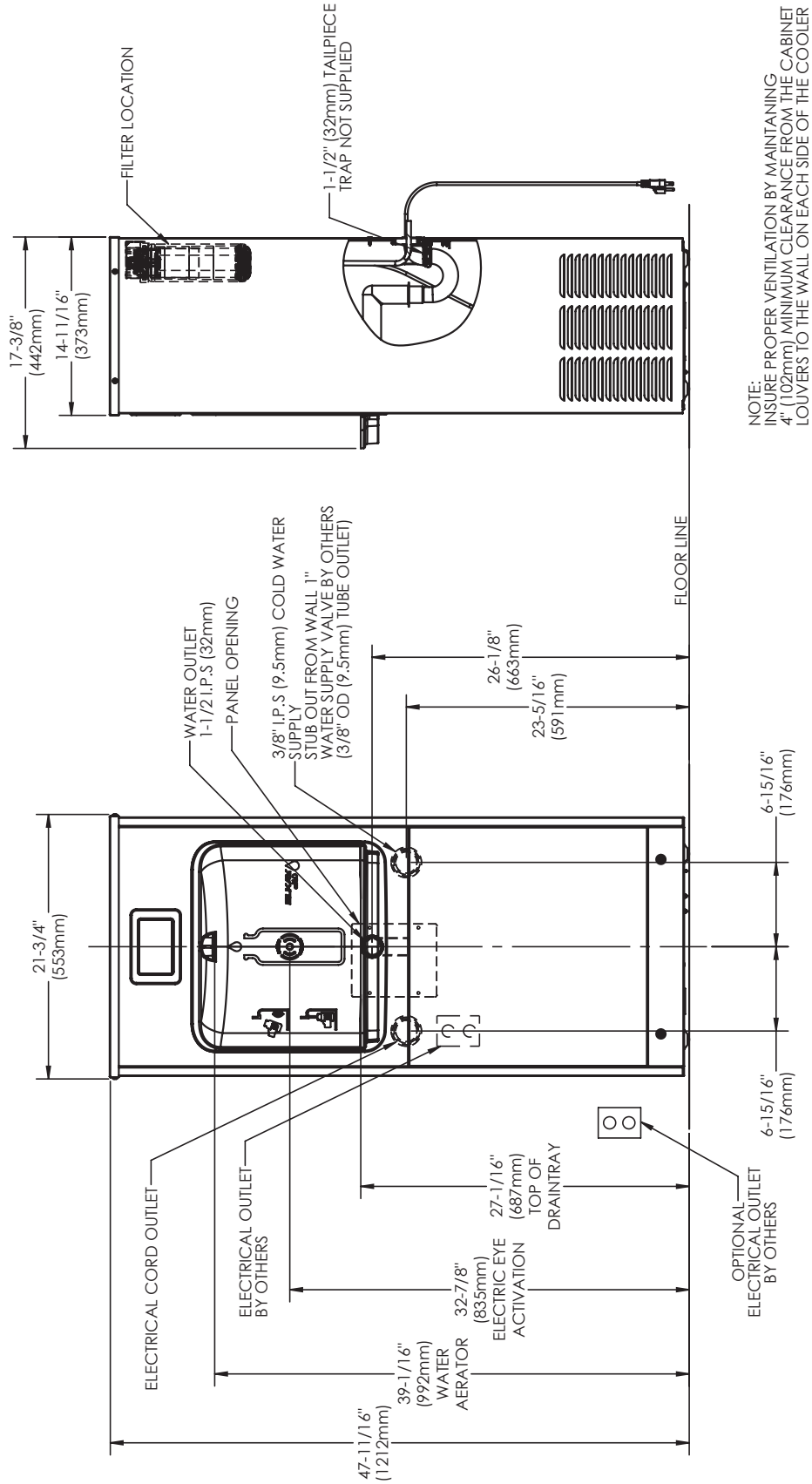

NOTE:  
INSURE PROPER VENTILATION BY MAINTAINING  
4" (102mm) MINIMUM CLEARANCE FROM THE CABINET  
LOUVERS TO THE WALL ON EACH SIDE OF THE COOLER

NOTE:  
NEW INSTALLATIONS MUST USE GROUND FAULT CIRCUIT INTERRUPTER (GFCI) IT IS HIGHLY RECOMMENDED  
THAT THE CIRCUIT BE DEDICATED AND THE LOAD PROTECTION BE SIZED FOR 20 AMPS.

## Use Proper Tools



Always use proper tools which are in good working condition during the installation of the product. Using tools other than those listed could adversely affect the product and could result in property damage.

## 2.4 Property Damage



### Inspect Before Cutting

Make sure no electrical wiring or plumbing is present before cutting into a wall.

## 3. Tools and Supplies

### 3.1 Tools Required

Tool	Used For
Power Drill	Installation of anchor fasteners for securing unit to floor
Adjustable Pliers	Installation of P-trap
Adjustable Wrench	Installation of water inlet valve
Hacksaw	Trimming waste outlet pipe
Flat Blade Screwdriver	Adjustment of pressure regulator and coldness control valve
5/16" Nut Driver	Removal of mounting bracket and front panel
Tubing Cutters	To trim excess poly tube
Phillips Screwdriver	To install the top access panel on top of the cooler unit

### 3.2 Installer-Supplied Parts

Description	Qty.
Fasteners to anchor unit to floor (varies due to flooring surface)	2
Flat washers	2
P-trap with 1-1/2" inlet (single unit)	1
Quarter turn shut-off valve with angled 3/8" outlet (filtered units)	1

## 4. Preparation

### 4.1 General Information

1. This water cooler is designed for indoor use only and should not be installed outdoors or in a humid environment.

**NOTICE** A water supply pressure below 20 psi will result in decreased water flow through the unit and damage to the product. A pressure above 105 psi will also cause damage to the product.

2. Make sure the water supply pressure to the product is between 20 and 105 psi. The filtered units require 40 psi minimum water pressure.
3. Use care when opening and removing the packaging to prevent damage to the product.
  - a. Inspect the product for any shipping damage and report it immediately to the location of purchase. Installation of a damaged product will void the warranty.
  - b. Confirm that all parts have been included for the proper installation of this product. Contact the location of purchase if damaged parts are found.

**NOTICE** Make sure no electrical wiring, potable water inlet pipes, or drain water outlet pipes will be damaged during installation of the product. Damage to any of these items can cause electrical damage, fire, and/or water damage.

4. Shut off the water supply source and disconnect power to the electrical outlet being used to operate the product before starting installation.

**NOTICE** Mounting hardware to be supplied by customer.

### 4.2 Water, Waste, and Electrical Locations

This section contains general information for the required utilities for the cooler. Use the Location Drawing in each section to determine the exact location of the utilities.

1. Install water supply in accordance with local plumbing codes.
  - a. Use at least 3/8" O.D. unplated copper tube for supply line.
  - b. Pipe should extend 3" (76mm) maximum from wall.
  - c. Install a quarter-turn, installer supplied, shut-off valve.

**NOTICE** Connect shut-off valve to water inlet. Do not use a piercing-type saddle valve for supply water which will reduce water flow and clogs easier.

*Note: This water cooler has been designed and built to provide water to the user which has not been altered by materials in the cooler waterways. The grounding of electrical equipment such as telephones, computers, etc. to water lines is a common procedure. The grounding may be in the building but may also occur away from the building. This grounding can cause electrical feedback into a water cooler creating an electrolysis, which creates a metallic taste or causes an increase in the metal content of the water.*

**NOTICE** Water cooler must be connected to the water supply using a dielectric coupling. The cooler is furnished with a non-metallic strainer which meets this requirement. The drain trap which is provided by the installer should also be plastic to completely isolate the cooler from the building plumbing system.

2. Install a waste water drain.
  - a. Waste outlet must be minimum 1-1/4" O.D. for single units.
  - b. Pipe should extend 2" (50mm) from wall.
3. Install a grounded, three-prong electrical outlet on a dedicated circuit.
  - a. 115 Volt, 60 Hz AC.
  - b. Install a dedicated 20A fused circuit.
  - c. Ground-fault circuit interrupter (GFCI) protection is required by the National Electrical Code (NFPA 70). For optimal performance a 20 amp hospital grade GFCI protection device is suggested.

**WARNING** To prevent electrical shock, fire, or electrocution, install a grounded three-prong outlet. Do not modify supplied power cord. Do not use an adapter or extension cord.

**SAFETY INSTRUCTIONS** To ensure proper electrical safety, the electrical supply circuit should have GFCI protection and AFCI protection, as required by federal and local electrical safety codes and standards.

## 5. Installation of Cooler

1. Remove the drain access panel by removing the 5/16" hex screws on the rear side of the cooler unit.

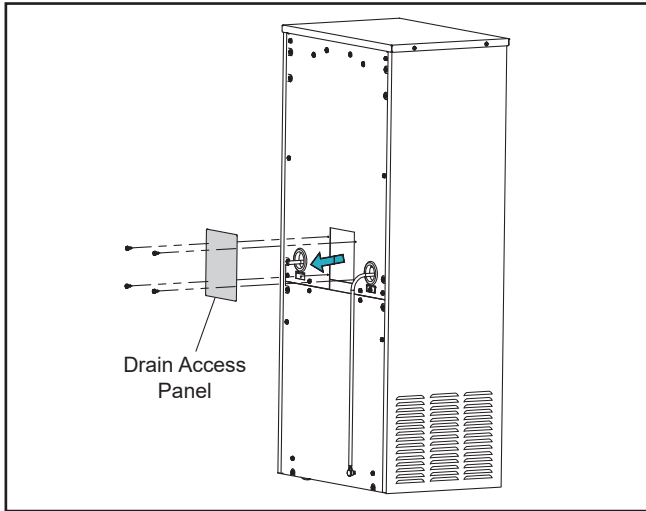

2. Position the cooler unit facing front side.

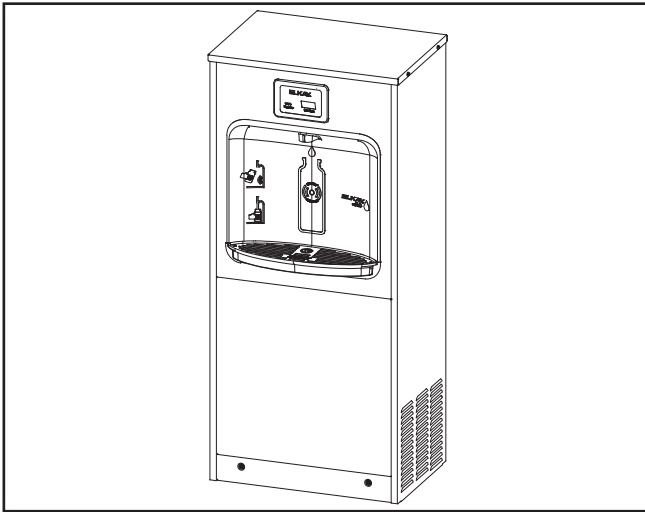

3. Remove the lower front panel by removing the two hex screws on the cooler unit using a 5/16" socket or nut driver.

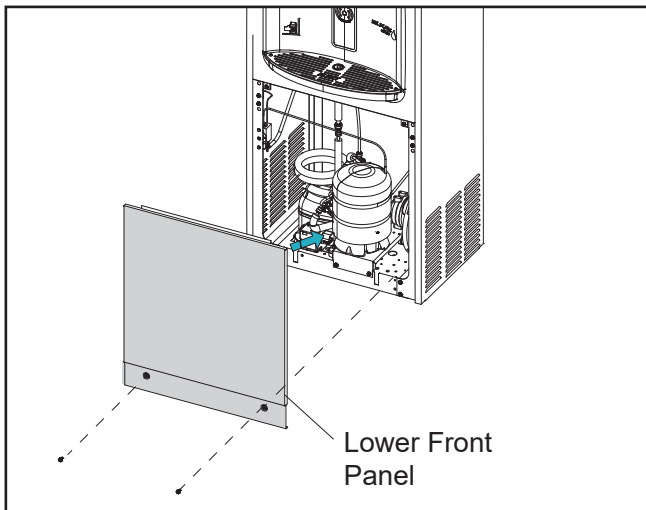

4. Take the filter box and drain kit package out of the cooler unit.

**Note:** Filter box and drain kit are packed inside the cooler unit during shipment.

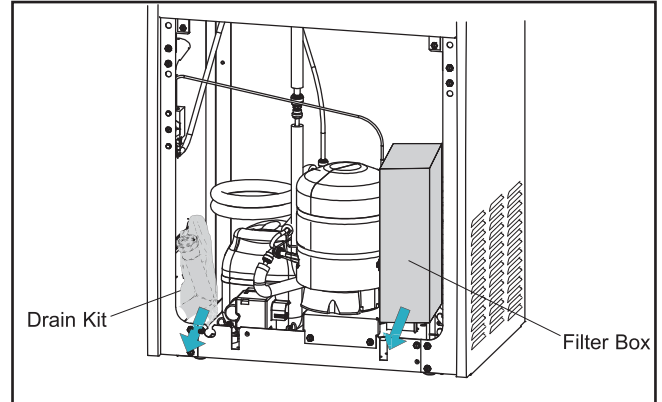

5. Attach the nut, the seal, and the elbow tube to the drain outlet and tighten it fully.

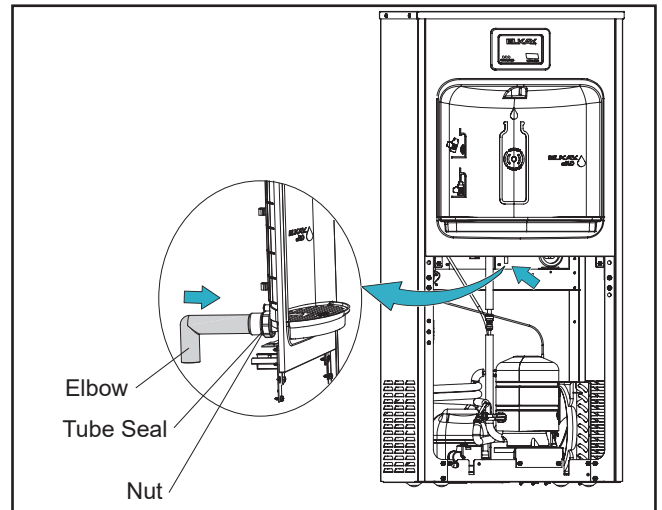

6. Connect one end of P-trap to the water drain tube and other end to the drain outlet.

**Note:** P-trap is installer supplied part.

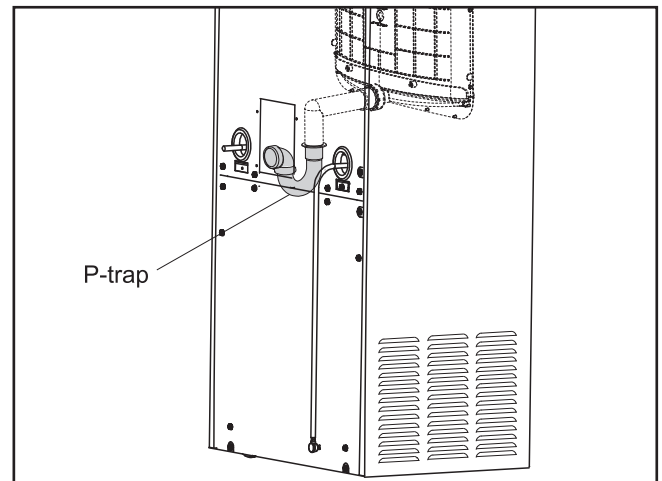

7. Remove the top access panel by removing the four phillips screws on the top of the cooler unit using a phillips screwdriver.

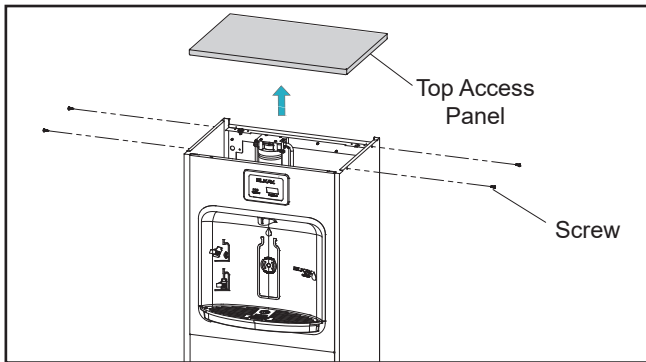

8. Connect the unit water line to shut-off valve.  
**Note:** Shut-off valve not shown (installer supplied part).

9. Connect the water inlet tube to the inlet of filter assembly.

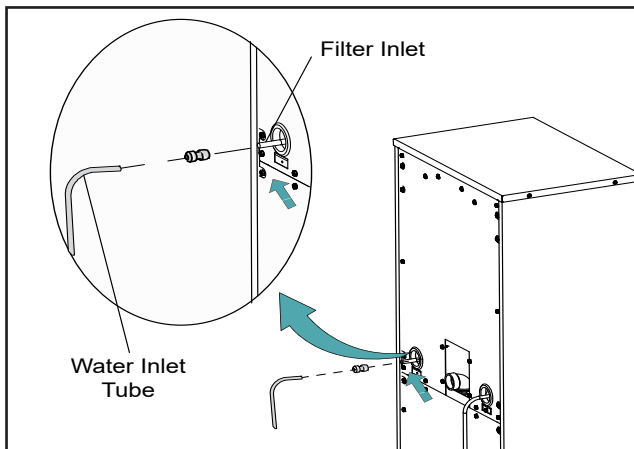

10. Installation of filter.
- Remove the filter from the carton.
  - Remove the protective cap.
  - Mark the current date on the water filter label.
  - Attach the filter to the filter head with label facing outward by firmly inserting into the head and by rotating the filter head clockwise, if required.

**Note:** Filter label should be readable from the front of the filter during installation.

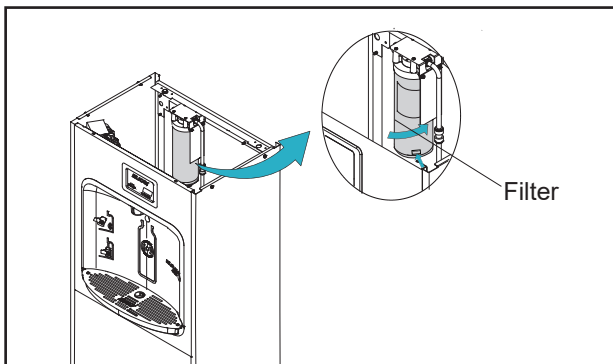

11. Use the four phillips screws to install the top access panel on top of the cooler unit. Tighten the four phillips screws fully using a phillips screwdriver.

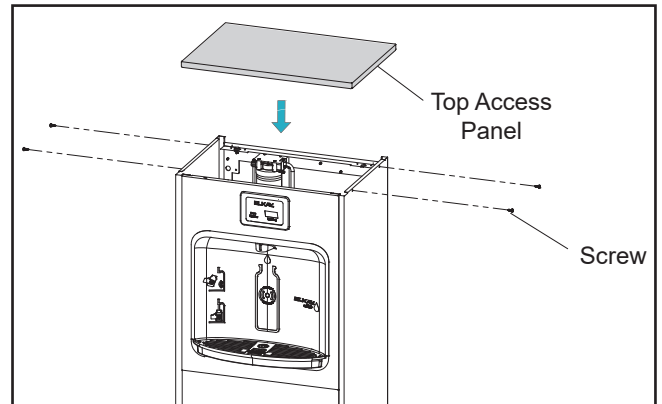

12. Secure the cooler unit to the floor using the existing holes in the base plate with anchor fasteners.

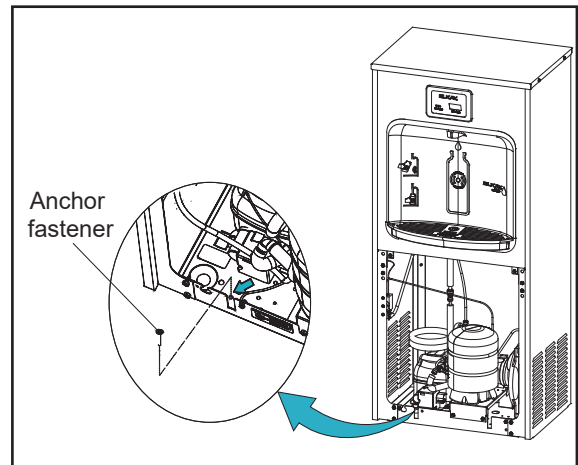

## 6. Startup

1. Make sure that there are no leaks on the drain connections and installed as per local regulations.
2. Plug-in the water cooler unit.
3. Once power is applied to the bottle filler, the GREEN LED light will illuminate showing good filter status along with the LCD Bottle Counter.
4. Verify proper dispensing by placing cup or any object in front of sensor area and verify water dispenses.

**Note:** The first initial dispenses might have air in line which may cause a sputter. This will be eliminated once all air is purged from the line.

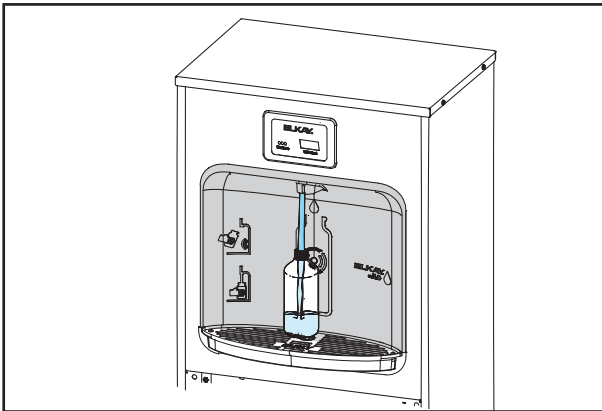

5. Check all the lines and connections for water leaks. Repair connections if necessary.
6. Dispense at least two gallons of water to bleed off any trapped air from supply lines and fine carbon particles from the filter. If there are no leaks and unit is functioning correctly, re-install the front cover by installing the two hex screws on the bottom side of the cooler using a 5/16" socket or nut driver.

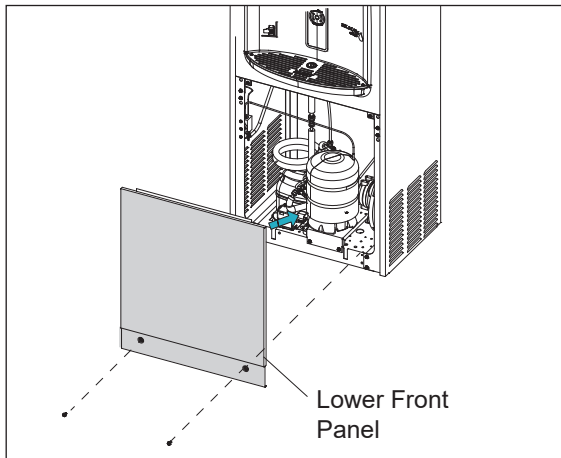

7. Upon initial startup, the plastic bottles saved indicator panel should show several bottles saved due to the water used to initially start up of the unit.

GREEN: 0 - 80% of Filter Life or 0 - 11 Months.

YELLOW: 80 - 100% of Filter Life or 11 - 12 Months (Whichever Comes First).

RED: 100% Plus of Filter Life or 12 Months (Whichever Comes First).

## 7. Accessing the Programming Button

1. Remove the bottle filler top cover by removing the four phillips screws using a phillips screwdriver. Do not discard the screws, they are required for re-assembly.
2. Locate the programming button at the top left side of the unit on the control board.

## 8. Cleaning Instruction

### 8.1 Stainless Steel

1. General Cleaning: Use an ordinary mild detergent and soft cloth, rinse and towel dry.
2. Steel soap pads should never be used; particles can adhere to a stainless steel basin surface and will eventually rust.
3. Light scratches are normal for stainless steel over time they will blend into the uniform finish pattern.

### 8.2 Plastic Components

1. General cleaning: Use an ordinary mild detergent and soft cloth, rinse and towel dry.
2. Wiping the surface clean to remove debris or build up will not hurt the antimicrobial properties.

## 9. Filter Cartridge Replacement for Filtered Units Only

1. Shut off water supply using the shut off valve. Turn water shut off valve handle to the OFF position (clockwise).

**Note:** This view may be different depending on model and configuration.

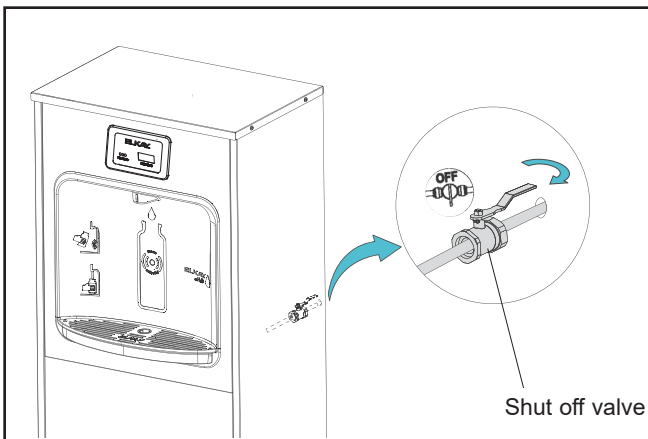

2. Activate the water dispenser with a water bottle to relieve pressure and access water in the water line.

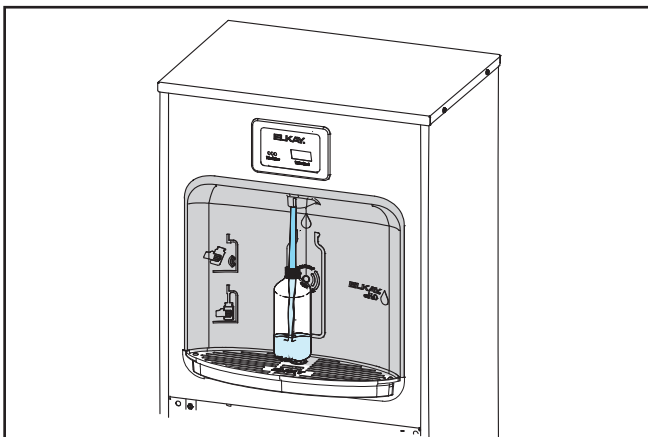

3. Shut OFF power to the unit by unplugging.

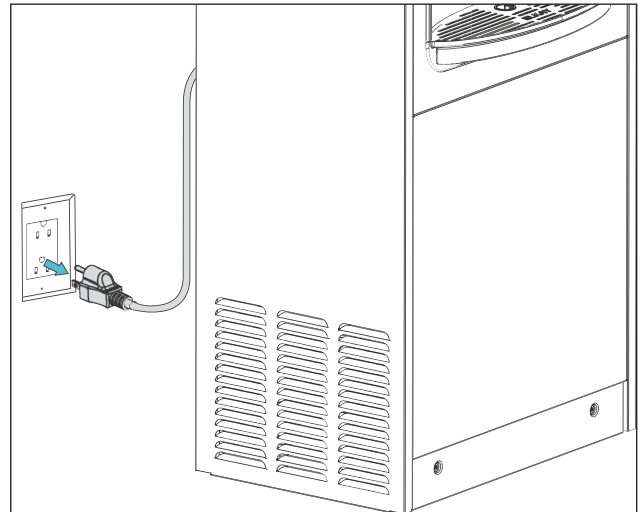

4. Remove the top access panel by removing the four phillips screws on the top of the cooler unit using a phillips screwdriver.

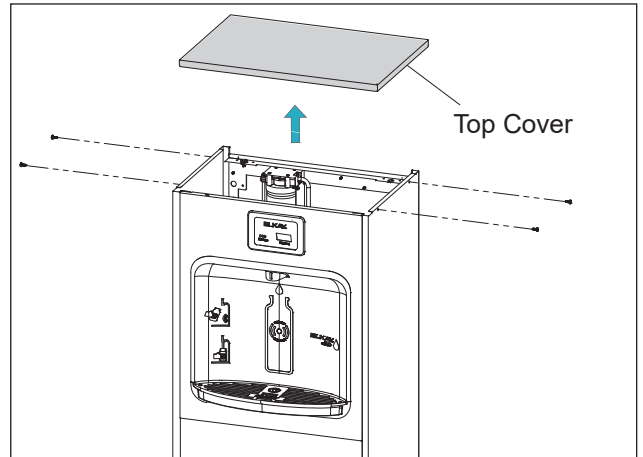

5. Locate current filter on the top of cooler unit.

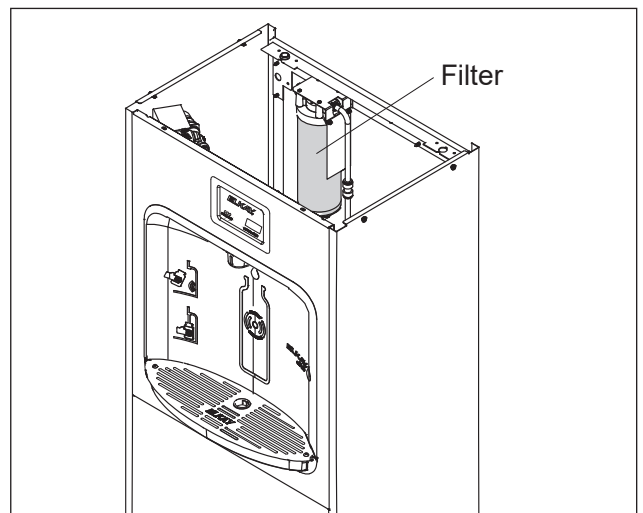

6. Place a towel under the filter to absorb any water that leaks out of the filter when it is removed.

7. Twist the filter clockwise until it is disengaged. Remove the filter and keep upright; remove towel.

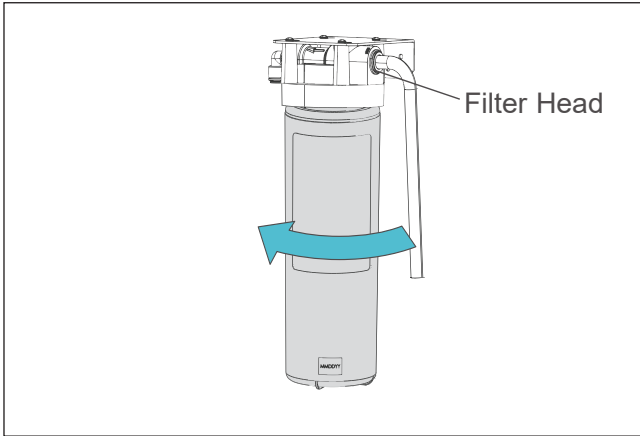

8. Drain the filter before disposing in a trash can.
9. Remove protective cap from the new filter.

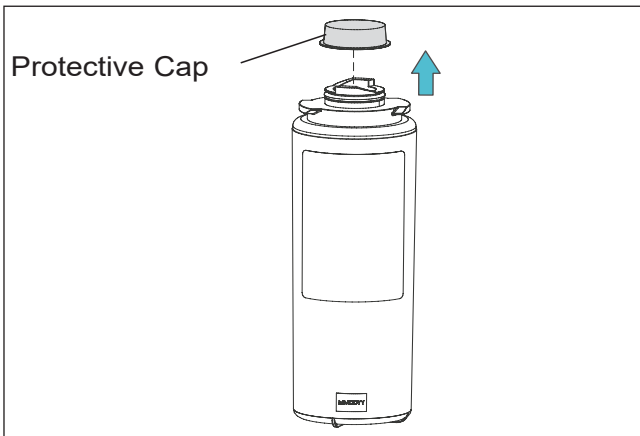

10. Mark the current date on the filter label.
11. Attach the filter to the filter head with label facing outward by firmly inserting into the head and by rotating the filter head counterclockwise, if required.

**Note:** Filter label should be readable from the front of the filter during installation.

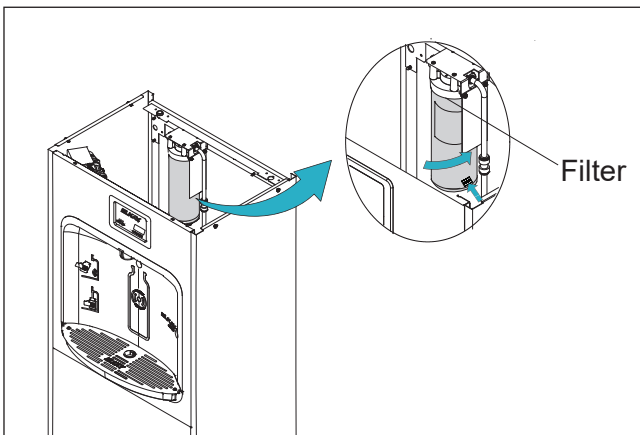

12. Restore power back to the unit.

13. Turn on water supply.
14. Verify proper dispensing by placing cup or any object in front of sensor area and verify water dispenses. Dispense at least two gallons of water to bleed off any trapped air from supply lines and fine carbon particles from the filter.

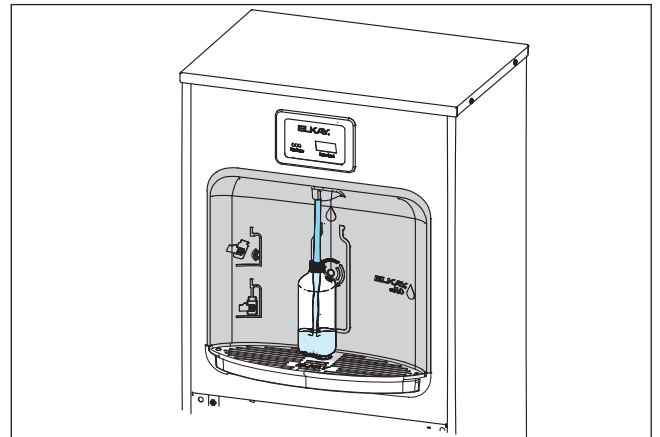

15. Check all the lines and connections for water leaks. Repair connections if necessary.

**Note:** Once power is applied to the bottle filler, the GREEN LED light should illuminate showing good filter status along with the LCD Bottle Counter.

- GREEN: 0 - 80% of Filter Life or 0 - 11 Months (Whichever Comes First).
- YELLOW: 80 - 100% of Filter Life or 11 - 12 Months (Whichever Comes First).
- RED: 100% Plus of Filter Life or 12 Months (Whichever Comes First).

16. Attach the top cover on the cooler unit.

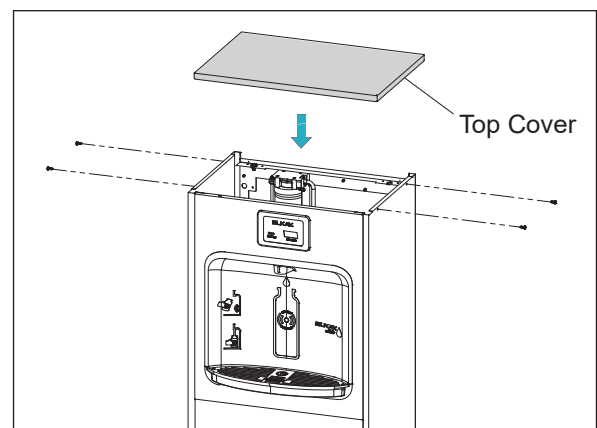

17. Install the 4 phillips screws using a phillips screwdriver.

115V Refrigerated Wiring Diagram with Alpha/Numeric Display (Enhanced only)

DSSBF8SP

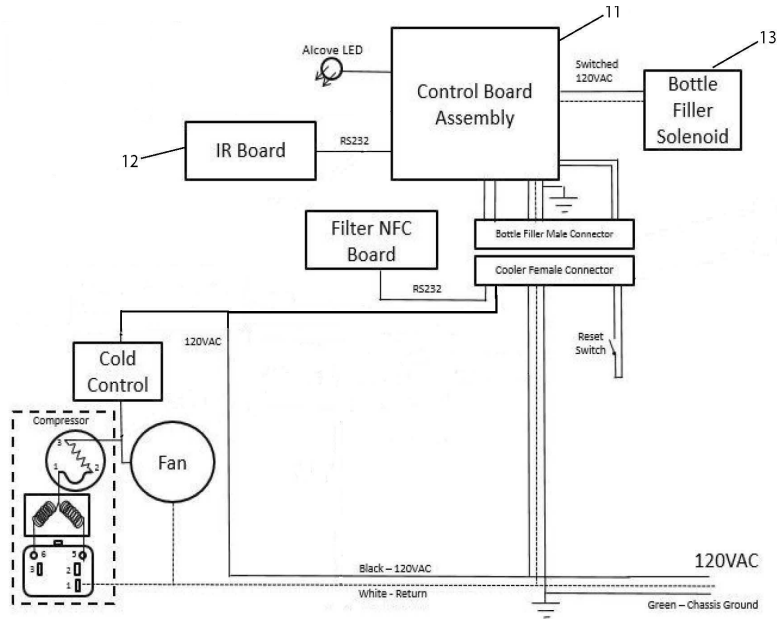

Fig. 1

115V Refrigerated Wiring Diagram with Alpha/Numeric Display (Connected)

DSSBF8SP-W1

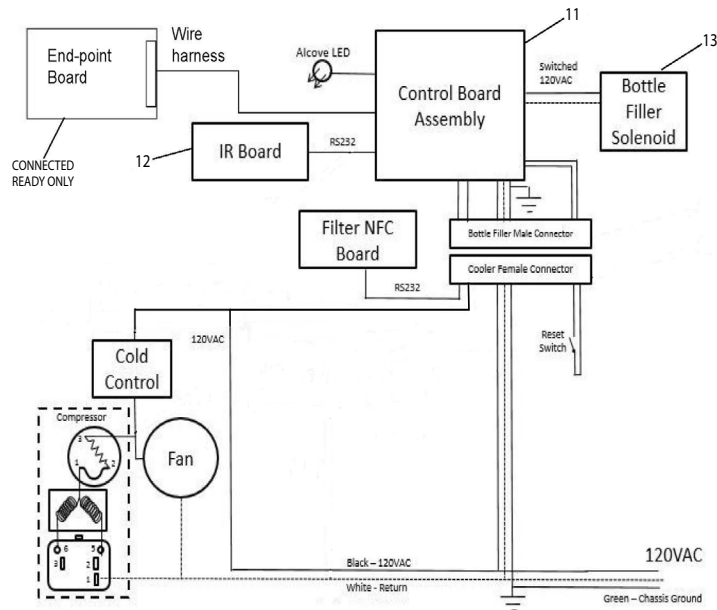

Fig. 2

**WARNING**

- **INGESTION HAZARD:** This product contains a button cell or coin battery.
- **DEATH** or serious injury can occur if ingested.
- A swallowed button cell or coin battery can cause **Internal Chemical Burns** in as little as **2 hours**.
- **KEEP** new and used batteries **OUT OF REACH** of **CHILDREN**
- **Seek immediate medical attention** if a battery is suspected to be swallowed or inserted inside any part of the body.





Fig. 3

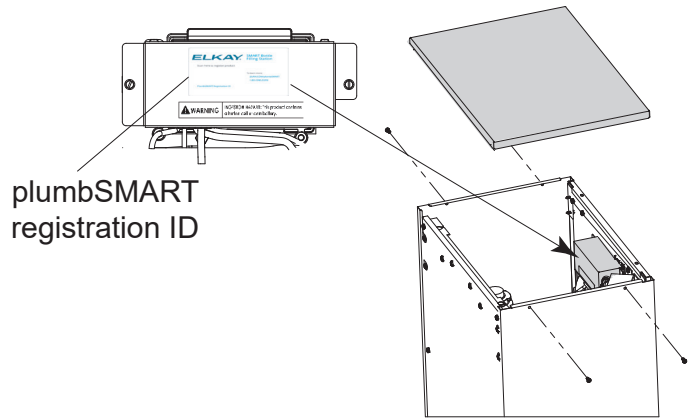

Fig. 4



Scan for trouble shooting and to sign up for auto replenishment of authentic Elkay filters.

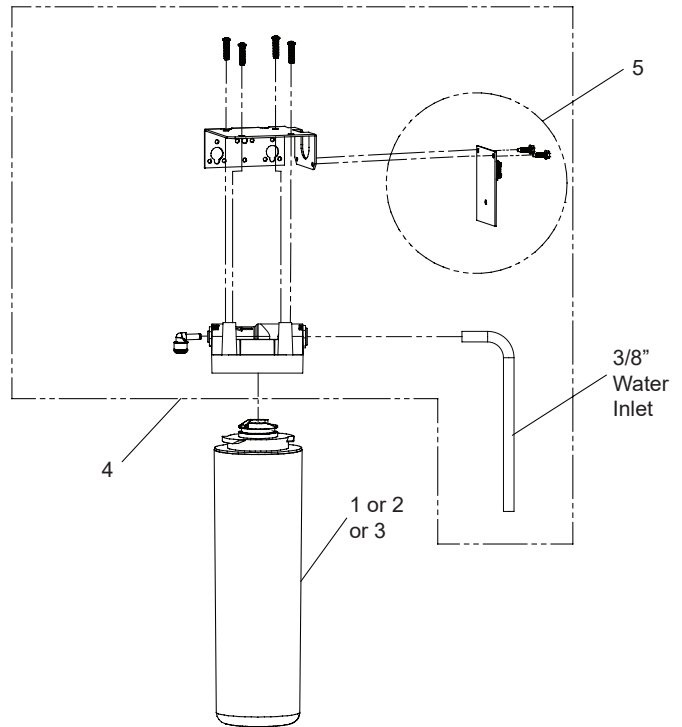
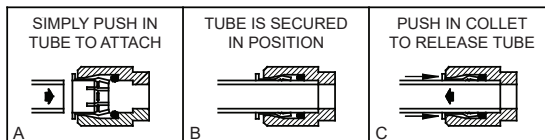

Fig. 5

OPERATION OF QUICK CONNECT FITTINGS



PUSHING TUBE IN BEFORE PULLING IT OUT HELPS TO RELEASE TUBE

Fig. 6

WATERSENTRY® Filter Detail

WATERSENTRY® FILTER PARTS LIST		
ITEM NO.	PART NO.	DESCRIPTION
1	51300C	Filter 3000 Gal (standard)
2	51600C	Filter 6000 Gal (high capacity)
3	71300C	Filter 2250 Gal (PFOA/PFAS)
4	1000005214	Kit - Filter Head Fittings includes John Guest Fittings & 3/8" Elbow Filter Bracket/Screws
5	1000004409	Kit - NFC Board/Cover



## Enhanced EZH2O Error Codes

Error Code	Error Description	Corrective Action
	Bottle filler area obstructed	<ul style="list-style-type: none"> <li>• Remove obstruction.</li> <li>• Clean lens on IR sensor</li> <li>• Unplug unit for at least 30 seconds and restart</li> <li>• If error repeats, replace IR sensor</li> </ul>
E013	Missing or Incompatible Filter	<ul style="list-style-type: none"> <li>• Check that filter is installed correctly (label facing forward, white tag facing back)</li> <li>• Unplug unit for at least 30 seconds and restart</li> <li>• Replace filter</li> <li>• Replace filter head assembly with repair kit</li> <li>• If error repeats, contact certified service professional</li> </ul>
E013 & E014	Missing NFC Board	<ul style="list-style-type: none"> <li>• Unplug unit for at least 30 seconds and restart</li> <li>• Verify cable connector is plugged into NFC board on filter head assembly</li> <li>• Replace filter head assembly with repair kit</li> <li>• If error repeats, contact certified service professional</li> </ul>

**Note:** *Danger! Electric shock hazard. Disconnect power before servicing unit.*

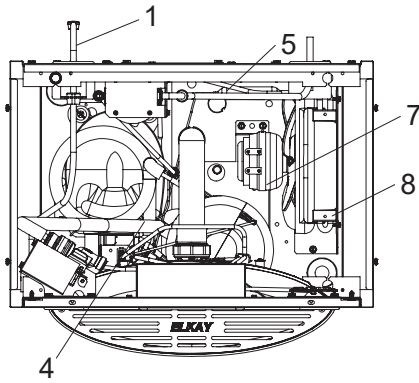

**Fig 7: Cooler Top View**

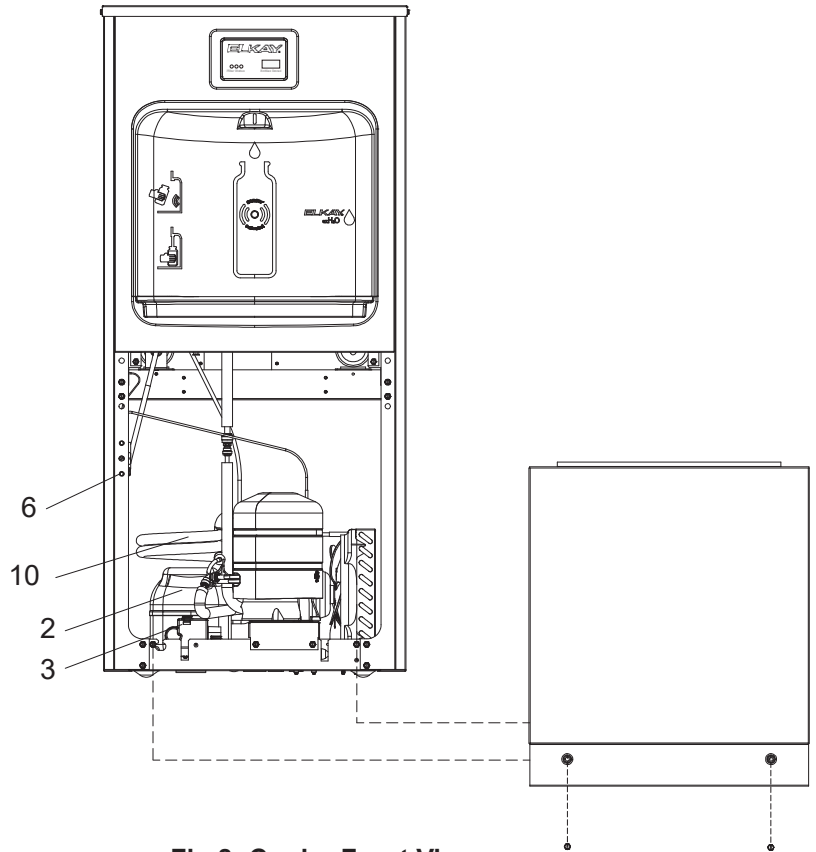

**Fig 8: Cooler Front View**

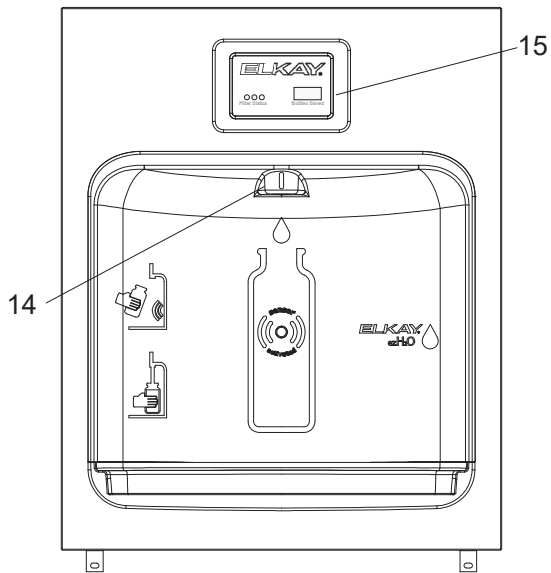

**Fig 9: Front View with Aerator**

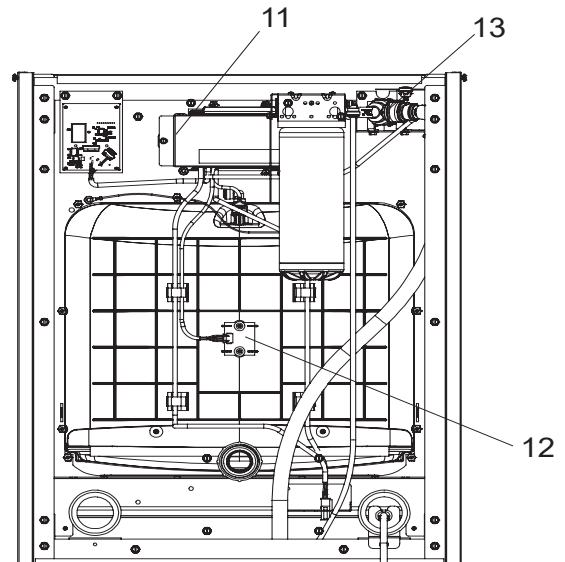

**Fig 10: Rear View**

**115V PARTS LIST**

ITEM NO.	PART NO.	DESCRIPTION
1	36287C	Power Cord
2	*36322C	Compressor Serv. Pak EMIS70HHR
3	0000000238	Kit - Electricals /OL/Relay/Cvr
4	56092C	Tubing - Poly (Cut To Length)
5	66703C	Drier
6	98773C	Kit - Cold Control/Screws
7	98775C	Kit - Fan Motor Assy/Blade/Motor/Shroud/Nut
8	98776C	Kit - Condenser/Drier
NS	98777C	Kit - Compr Mtg Hdwe
10	98778C	Kit - 66576C Heatx/Drier
11	2000001906	PCBA, Main Control Board (Midnight)
12	1000005219	Kit - IR Sensor K+
13	1000004573	Kit - Solenoid 120V (BF)
14	98546C	Kit - Aerator Replacement
15	2000001999	Nameplate - Elkay Filtered K+ (Std Gry)
NS	98549C	Kit - Hardware & Waterway (BF)
NS	1000004546	Harness - Bottle Filler
NS	1000004549	Harness - LED/IR Board
NS	1000004547	Harness - Cooler
NS	1100000025	Endpoint Board Service Kit

NS = Not Shown

**\*INCLUDES RELAY & OVERLOAD. IF UNDER WARRANTY, REPLACE WITH SAME COMPRESSOR USED IN ORIGINAL ASSEMBLY.**  
**NOTE:** All correspondence pertaining to any of the above water coolers or orders for repair parts MUST include Model No. and Serial No. of cooler, name and part number of replacement part.

## LIMITED PRODUCT WARRANTY SOFTWARE LICENSE

**FIRST YEAR** - The Manufacturer warrants every cooler, bottle filling station, packaged water cooler, fountain and accessory to be free from defects in materials and workmanship under normal use for one (1) year from date of install or eighteen (18) months from date of shipment from factory, whichever occurs first. The Manufacturer warrants every LK44 Series outdoor tubular fountain and bottle filling station to be free from defects in materials and workmanship under normal use for five (5) years from the date of install or sixty-six (66) months from date of shipment from factory, whichever occurs first. This extended warranty does not apply to freeze resistant assemblies.

**SECOND THROUGH FIFTH YEARS** - The Manufacturer warrants the compressor and hermetically sealed refrigeration system, including cooling coils or tank assembly when part of the hermetically sealed refrigeration system, to be free from defects in material and workmanship under normal use for an additional four (4) years from the end of the one (1) year period described above. Packaged water cooler are not subject to the additional four (4) year warranty when used in chilled water commercial/industrial applications other than for potable water.

**INSTALLATION AND OPERATION** - The foregoing Limited Warranty applies only when the product is installed and operated in accordance with the Manufacturer's written instructions included with each unit. These products are designed to operate on 20 psi to 105 psi supply line pressure. Non-filtered Bi-level units require a minimum of 40 psi supply line pressure to ensure adequate stream height from each bubbler when activated simultaneously. Bi-level filtered models, regardless of supply line pressure, cannot provide adequate stream height from each bubbler when activated simultaneously. The Limited Warranty does not apply to products, which on examination by the Manufacturer or its agent, are found to have been subjected to accident, alteration, abuse, misuse, misapplications, corrosive type atmospheres, or abnormal use.

**OWNER'S OBLIGATIONS** - It is the owner's obligation to pay for any repairs or maintenance not covered by the Limited Warranty, including service calls related to non warranty issues. Any appearance imperfections are to be noted at time of installation, and the installer or the supplier notified without delay. In the case of products located within the United States or Canada, it is the owner's responsibility to allow access to the unit for the authorized service center to repair on site and/or remove unit from wall to repair at the authorized service center's discretion. In the case of products located outside the United States or Canada, the owner is to return any part for which replacement is sought to the closest authorized service center or to the manufacturer's factory repair department.

**MANUFACTURER'S OBLIGATIONS** - When the product is located within the United States or Canada, the Manufacturer's obligation under this Limited Warranty is limited to the labor and parts to repair or replace any part which is expressly covered by this Limited Warranty at one of its authorized service centers or at its factory repair department. The warranty applicable to any replacement unit shall be the remaining warranty period on the replaced unit. The Manufacturer's obligation also includes cost of outbound freight (but not express freight) of the part or parts from an authorized service center or the factory repair department, but only if the Manufacturer determines that the part or parts, and the purported defect or defects, are covered by this Limited Warranty.

When the product is located outside the United States or Canada, the Manufacturer's obligation under this Limited Warranty is limited to providing a replacement part for any part expressly covered by this Limited Warranty which, upon examination by the Manufacturer or its agent, is found to be defective, but does not include any obligation to provide labor or to pay labor costs incurred in connection with the replacement. The Manufacturer's obligations also include cost of outbound freight (but not express freight) of the part or parts from the factory repair department to (but not beyond) the port in the United States from which the part or parts are shipped to the ultimate destination, but only if the Manufacturer determines that the part or parts, and the purported defect or defects, are covered by this Limited Warranty.

**WHAT WARRANTY DOES NOT COVER** - This Limited Warranty does not include payment for any field labor to provide for normal maintenance including adjustments such as water stream height, water temperature or electric eye sensitivity. The water system and regulating valve are not covered by this Limited Warranty if they become inoperative due to liming, sand or similar residue. This Limited Warranty is voided if repairs are made by an unauthorized party or the serial number data plate is removed or defaced. Normal deterioration of finish due to use and exposure is not covered by this Limited Warranty. Corrosion of materials is also not covered by this Limited Warranty. The Manufacturer is not liable for repairs, whether cosmetic or structural, to walls where cooler, bottle filler, fountain and packaged water coolers are built into the wall. If inlet pressure is above 105 psi, a pressure regulator must be installed in the supply line. Any damage caused by reason of connecting this water cooler, bottle filler, fountain or packaged water cooler to supply line pressures lower than 20 psi or higher than 105 psi is not covered by this warranty.

**PERSONS ENTITLED TO BENEFIT OF WARRANTY** - This Limited Warranty is applicable only to (i) purchasers who purchase the product for the resale in the ordinary course of business, and (ii) the first person who purchases the product other than resale.

**SOFTWARE LICENSE PROVISIONS** - To the extent the product includes embedded software, the owner and those using the product are granted a restricted, nonexclusive license to use such embedded software. Title to the embedded software shall at times remain with the embedded software licensor. The owner and those using the product shall not remove or alter notices, legends or trademarks contained in the embedded software, nor shall they translate, reverse engineer, decompile or disassemble the embedded software except to the extent applicable law specifically prohibits this restriction. The embedded software is provided "as is" and any warranty offered herein is by or through the Manufacturer. Further information concerning this license of embedded software is available from the Manufacturer.

THIS LIMITED WARRANTY IS IN LIEU OF ALL OTHER EXPRESS WARRANTIES, EXPRESSED OR IMPLIED, ARISING BY LAW OR OTHERWISE, INCLUDING WITHOUT LIMITATION, THE IMPLIED WARRANTIES OF MERCHANTABILITY AND FITNESS FOR A PARTICULAR PURPOSE. EXCEPT AS EXPRESSLY PROVIDED HEREIN, THE MANUFACTURER MAKES NO WARRANTIES, EXPRESSED OR IMPLIED, ARISING BY LAW OR OTHERWISE, INCLUDING WITHOUT LIMITATION, THE IMPLIED WARRANTIES OF MERCHANTABILITY AND FITNESS FOR A PARTICULAR PURPOSE, TO ANY PERSON. THIS WARRANTY MAY NOT BE ALTERED, VARIED, OR EXTENDED, EXCEPT BY A WRITTEN INSTRUMENT EXECUTED BY THE MANUFACTURER. THE REMEDY OF REPAIR OR, WHERE APPLICABLE, REPLACEMENT AS PROVIDED UNDER THIS LIMITED WARRANTY IS EXCLUSIVE. IN NO EVENT SHALL THE MANUFACTURER BE LIABLE FOR ANY CONSEQUENTIAL OR INCIDENTAL DAMAGES TO ANY PERSON, WHETHER OR NOT OCCASIONED BY NEGLIGENCE OF THE MANUFACTURER, INCLUDING WITHOUT LIMITATION DAMAGES FOR LOSS OF USE, COSTS OR SUBSTITUTION, PROPERTY DAMAGE, OR OTHER MONETARY LOSS.

This Limited Warranty gives specific legal rights and in some states of the United States there may be other rights which vary from state to state.

DATE OF INSTALLATION \_\_\_\_\_

SERIAL NUMBER \_\_\_\_\_  
(To Be Filled in By Installer)

Form to be left with the owner by the installer.

**FCC COMPLIANCE STATEMENT**

CAUTION: Changes or modifications not expressly approved could void your authority to use this equipment  
This device complies with Part 15 of the FCC Rules. Operation to the following two conditions: (1) This device may not cause harmful interference, and (2) this device must accept any interference received, including interference that may cause undesired operation

Note: This equipment has been tested and found to comply with the limits for a Class B digital device, pursuant to part 15 of the FCC Rules. These limits are designed to provide reasonable protection against harmful interference in a residential installation. This equipment generates, uses and can radiate radio frequency energy and, if not installed and used in accordance with the instructions, may cause harmful interference to radio communications. However, there is no guarantee that interference will not occur in a particular installation. If this equipment does cause harmful interference to radio or television reception, which can be determined by turning the equipment off and on, the user is encouraged to try to correct the interference by one or more of the following measures:

- Reorient or relocate the receiving antenna.
- Increase the separation between the equipment and receiver.
- Connect the equipment into an outlet on a circuit different from that to which the receiver is connected.
- Consult the dealer or an experienced radio/TV technician for help.

The device shall be used in such a manner that the potential for human contact normal operation is minimized. This equipment complies with FCC radiation exposure limits set forth for an uncontrolled environment. This equipment should be installed and operated with a minimum distance of 20cm between the radiator and your body. This device and its antenna(s) must not be co-located or operating in conjunction with any other antenna or transmitter.

**INDUSTRY CANADA STATEMENT**

This device complies with Industry Canada license-exempt RSS standard(s). Operation is subject to the following two conditions: (1) this device may not cause interference, and (2) this device must accept any interference, including interference that may cause undesired operation of the device.

Le présent appareil est conforme aux CNR d'Industrie Canada applicables aux appareils radio exempts de licence. L'exploitation est autorisée aux deux conditions suivantes : (1) l'appareil ne doit pas produire de brouillage, et (2) l'utilisateur de l'appareil doit accepter tout brouillage radioélectrique subi, même si le brouillage est susceptible d'en compromettre le fonctionnement.

The device shall be used in such a manner that the potential for human contact normal operation is minimized. This equipment complies with RSS-102 radiation exposure limits. This equipment should be installed and operated with a minimum distance of 20 cm between the radiator and your body. This device and its antenna(s) must not be co-located or operating in conjunction with any other antenna or transmitter.

Le dispositif doit être utilisé de manière à minimiser le potentiel de fonctionnement normal par contact humain. Cet équipement est conforme aux limites d'exposition au rayonnement RSS-102. Cet équipement doit être installé et utilisé avec une distance minimale de 20 cm entre le radiateur et votre corps. Cet appareil et son (ses) antenne (s) ne doivent pas être co-localisés ou utilisés conjointement avec une autre antenne ou un autre émetteur.



PRINTED IN U.S.A.

FOR PARTS, CONTACT YOUR LOCAL DISTRIBUTOR OR CALL 1.800.834.4816  
REPAIR SERVICE INFORMATION TOLL FREE NUMBER 1.800.260.6640

ELKAY MANUFACTURING COMPANY • 1333 BUTTERFIELD ROAD • DOWNERS GROVE, IL 60515 • 630.574.8484 • www.elkay.com