

PRODUCT SPECIFICATIONS

Enhanced ezH2O® Floor Standing Bottle Filling Station Filtered Refrigerated Stainless Steel. Chilling Capacity of 8.0 GPH (gallons per hour) of 50° F drinking water, based on 80° F inlet water and 90° F ambient, per ASHRAE 18 testing. Features shall include Chilled Water, Hands Free, Antimicrobial*, Filtered, Green Ticker™, Visual Filter Monitor, Laminar Flow, Energy Savings. Electronic Bottle Filler Sensor activation. Product shall be Floor Mount/Freestanding, for Indoor applications, serving 1 station(s). Unit shall be certified to UL 399 and CAN/CSA C22.2 No. 120.



Special Features:	Chilled Water, Hands Free, Antimicrobial, Filtered, Green Ticker™, Visual Filter Monitor, Laminar Flow, Energy Savings
Finish:	Stainless Steel (S)
Power:	115V/60Hz
Bubbler Style:	No Bubbler
Activation by:	Electronic Bottle Filler Sensor
Mounting Type:	Floor Mount/Freestanding
Chilling Capacity*:	8.0 GPH
Full Load Amps	3
Dimensions (L x W x H):	21-1/2" x 15" x 48"
Approx. Shipping Weight:	94 lbs.
Installation Location:	Indoor
No. of Stations Served:	1
*Based on 80° F inlet water & 90° F ambient air temp for 50° F chilled drinking water.	

Special Note: Retrofit accessory, plumbSMART Gateway, and Account required for cloud connection.

COOLING SYSTEM

- Compressor: Hermetically-sealed, reciprocating type, single phase. Sealed-in lifetime lubrication.
- Condenser: Fan cooled, copper tube with aluminum fins. Fan motor is permanently lubricated.
- Cooling Unit: Combination tube-tank type. Continuous copper tubing with is fully insulated with EPS foam that meets UL requirements for self-extinguishing material.
- Refrigerant Control: Refrigerant R-134a is controlled by accurately calibrated capillary tube.
- Temperature Control: Easily accessible enclosed adjustable thermostat is factory preset. Requires no adjustment other than for altitude requirements.

Included with Product: Bottle filler, filter

Ships in one box.

A Century of Tradition and Quality. For more than 100 years, Elkay has been making innovative products and providing exceptional customer care. We take pride in offering plumbing products that make life easier, inspire change and leave the world a better place.



PRODUCT COMPLIANCE

- ADA & ICC A117.1
- CAN/CSA C22.2 No. 120
- FCC & ISED
- NSF/ANSI 42, 53, 61 (Q≤1), 372 (lead free), & 401
- UL 399



Complies with ADA & ICC A117.1 accessibility requirements when installed according to the requirements outlined in these standards. Installation may require additional components and/or construction features to be fully compliant. Consult the local Authority Having Jurisdiction if necessary.

[Installation Instructions \(PDF\) - 200002005](#)





5 Year Limited Warranty on the refrigeration system of the unit. Electrical components and water system are warranted for 12 months from date of installation. **Warranty pertains to drinking water applications only. Non-drinking water applications are not covered under warranty.**

[Warranty \(PDF\)](#)

PART: _____ QTY: _____
 PROJECT: _____
 CONTACT: _____
 DATE: _____
 NOTES: _____ APP
 ROVAL: _____

In keeping with our policy of continuing product improvement, Elkay reserves the right to change product specifications without notice. Please visit elkay.com for the most current version of Elkay product specification sheets. This specification describes an Elkay product with design, quality, and functional benefits to the user. When making a comparison of other producers' offerings, be certain these features are not overlooked.

Features	
<ul style="list-style-type: none"> • Connected-ready; use our retrofit accessory to set up wireless monitoring, track water usage and more. Accessory sold separately 	<ul style="list-style-type: none"> • FillSafe recognition automatically recognizes new filter and resets LED lights to blue
<ul style="list-style-type: none"> • Touchless, sensor-activated bottle filler, designed for easy use; retrofits existing EFA and LAFE 115V style coolers 	<ul style="list-style-type: none"> • Traditional floor mount design allows for floor-standing or wall-backed installations
<ul style="list-style-type: none"> • Green Ticker™ informs user of number of 20 oz. plastic water bottles saved from waste 	<ul style="list-style-type: none"> • The 3,000-gallon filter is tested and certified to NSF/ANSI 42, 53 and 401 to reduce lead, microplastics, Class 1 particulate, cysts, and chlorine taste and odor
<ul style="list-style-type: none"> • Visual filter monitor with LED filter status indicator displays when filter change is necessary 	<ul style="list-style-type: none"> • Hermetically sealed refrigeration system provides chilled water
<ul style="list-style-type: none"> • Impressive 48" standing height and 39" spout-to-floor distance for ease of use 	<ul style="list-style-type: none"> • Convenient single power cord design
	<p>*Antimicrobial claims are in reference to components manufactured antimicrobial agents, helping to provide clean, stain- and odor-free surfaces.</p>

Optional Accessories		
51300C	WaterSentry® Lead + Microplastics NSF/ANSI Certified 3000 Gal 12 Month Filter Spec Sheet (PDF)	
51600C	WaterSentry® Lead + Microplastics NSF/ANSI Certified 6000 Gal 12 Month Filter Spec Sheet (PDF)	
71300C	WaterSentry® PFOA/PFOS (PFAS) + Lead + Microplastics NSF/ANSI Certified 2250 Gal 12 Month Filter Spec Sheet (PDF)	
PLZSRK-W1	Connected Retrofit Kit with Endpoint Board for Enhanced Filtration Bottle Filling Stations Spec Sheet (PDF)	

In keeping with our policy of continuing product improvement, Elkay reserves the right to change product specifications without notice. Please visit elkay.com for the most current version of Elkay product specification sheets. This specification describes an Elkay product with design, quality, and functional benefits to the user. When making a comparison of other producers' offerings, be certain these features are not overlooked.

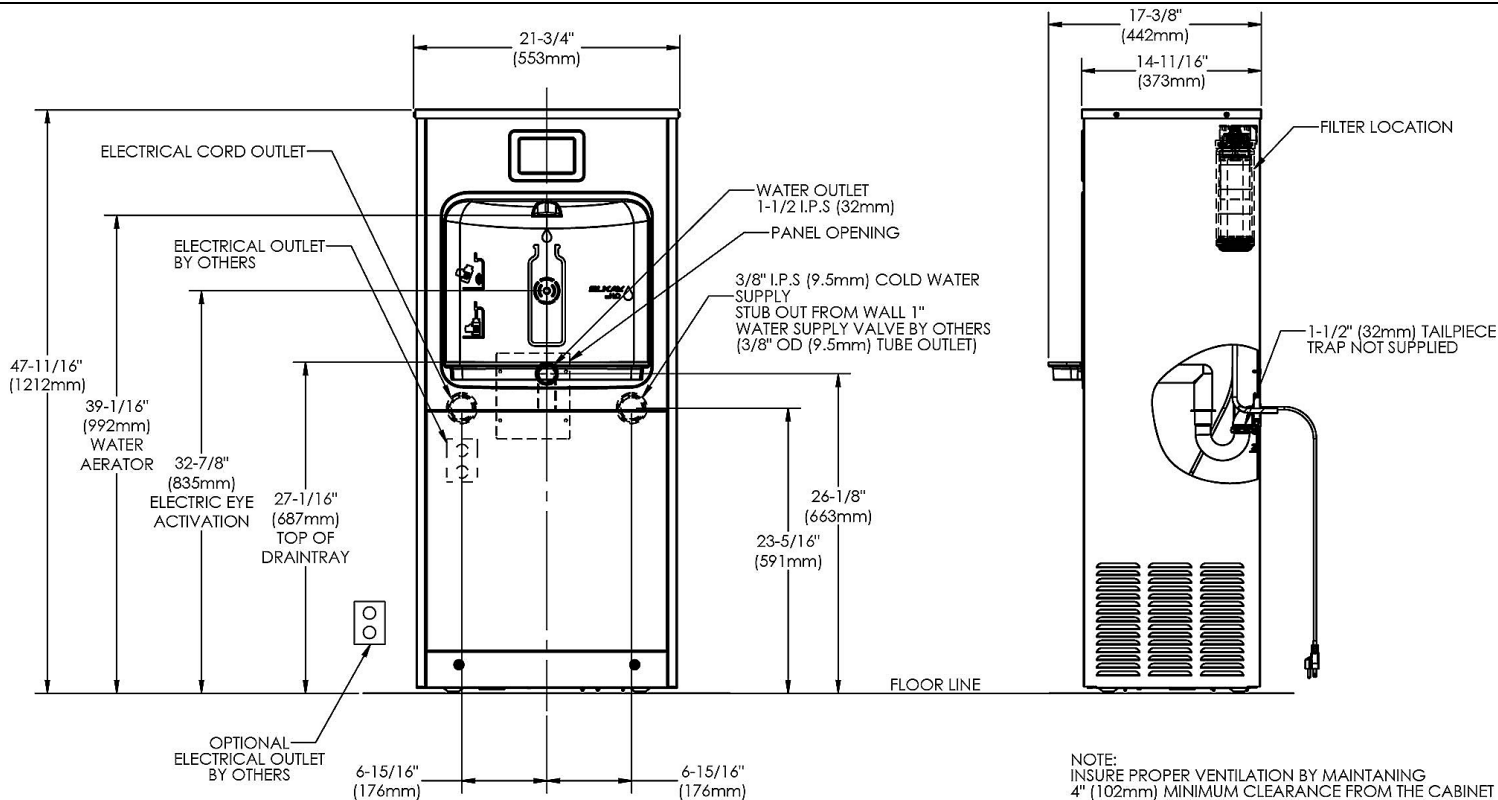

NOTE:
NEW INSTALLATIONS MUST USE GROUND FAULT CIRCUIT INTERRUPTER (GFCI) IT IS HIGHLY RECOMMENDED THAT THE CIRCUIT BE DEDICATED AND THE LOAD PROTECTION BE SIZED FOR 20 AMPS.

NOTE:
INSURE PROPER VENTILATION BY MAINTAINING 4" (102mm) MINIMUM CLEARANCE FROM THE CABINET LOUVERS TO THE WALL ON EACH SIDE OF THE COOLER

In keeping with our policy of continuing product improvement, Elkay reserves the right to change product specifications without notice. Please visit elkay.com for the most current version of Elkay product specification sheets. This specification describes an Elkay product with design, quality, and functional benefits to the user. When making a comparison of other producers' offerings, be certain these features are not overlooked.