

**PRODUCT SPECIFICATIONS**

SwirlFlo® Bi-Level Vandal Resistant Fountain Non-Filtered Non-Refrigerated Freeze Resistant Stainless. Features shall include Freeze Resistant. Furnished with Vandal Resistant bubbler. Mechanical Front Bubbler Button activation. Product shall be Wall Mount (On Wall), for Indoor + Outdoor applications, serving 2 station(s).

<b>Special Features:</b>	Freeze Resistant
<b>Finish:</b>	Stainless Steel (S)
<b>Power:</b>	No Electrical Required
<b>Bubbler Style:</b>	Vandal Resistant
<b>Activation by:</b>	Mechanical Front Bubbler Button
<b>Mounting Type:</b>	Wall Mount (On Wall)
<b>Chilling Capacity:</b>	Non-refrigerated
<b>Dimensions (L x W x H):</b>	38-1/2" x 19" x 21-15/16"
<b>Approx. Shipping Weight:</b>	100 lbs.
<b>Installation Location**:</b>	Indoor + Outdoor
<b>No. of Stations Served:</b>	2

\*\*When used in non-temperature controlled environments, unit(s) must be adequately winterized and/or protected from extreme heat to prevent damage where climates dictate.

- Mechanically-Activated unit continues to supply water in event of service disruptions.
- Freeze Resistant:
  - Depending on specific installation, freeze resistant system is located either below frost line or in temperature controlled space.



**Included with Product:** Fountain with Back Plate, Freeze Resistant Box, Surface Mounting

**▼ Ships in multiple boxes.**

A Century of Tradition and Quality. For more than 100 years, Elkay has been making innovative products and providing exceptional customer care. We take pride in offering plumbing products that make life easier, inspire change and leave the world a better place.



**PRODUCT COMPLIANCE**

- ADA & ICC A117.1
- ASME A112.19.3/CSA B45.4
- NSF/ANSI 61 (Q≤1) & 372 (lead free)



Complies with ADA & ICC A117.1 accessibility requirements when installed according to the requirements outlined in these standards. Installation may require additional components and/or construction features to be fully compliant. Consult the local Authority Having Jurisdiction if necessary.

- [Installation Instructions \(PDF\) - 98010C](#)
- [Installation Instructions \(PDF\) - 97566C](#)
- [Installation Instructions \(PDF\) - 97696C](#)

Water Systems are warranted for 12 months from date of installation. **Warranty pertains to drinking water applications only. Non-drinking water applications are not covered under warranty.**

[Warranty \(PDF\)](#)

PART: \_\_\_\_\_ QTY: \_\_\_\_\_

PROJECT: \_\_\_\_\_





CONTACT: \_\_\_\_\_

DATE: \_\_\_\_\_

NOTES: \_\_\_\_\_

APPROVAL: \_\_\_\_\_

*In keeping with our policy of continuing product improvement, Elkay reserves the right to change product specifications without notice. Please visit [elkay.com](http://elkay.com) for the most current version of Elkay product specification sheets. This specification describes an Elkay product with design, quality, and functional benefits to the user. When making a comparison of other producers' offerings, be certain these features are not overlooked.*

Optional Accessories		
<a href="#">EWF172</a>	Universal Filtration Kit (1500-Gallon) <a href="#">Spec Sheet (PDF)</a>	
<a href="#">AP99</a>	Access Panel 9" x 9" x 6" <a href="#">Spec Sheet (PDF)</a>	
<a href="#">LKAPR1</a>	Cane Apron for SwirlFlo® Gray <a href="#">Spec Sheet (PDF)</a>	
<a href="#">98481C</a>	Bubbler Kit Water-Efficient Vandal-Resistant <a href="#">Spec Sheet (PDF)</a>	

*In keeping with our policy of continuing product improvement, Elkay reserves the right to change product specifications without notice. Please visit [elkay.com](http://elkay.com) for the most current version of Elkay product specification sheets. This specification describes an Elkay product with design, quality, and functional benefits to the user. When making a comparison of other producers' offerings, be certain these features are not overlooked.*

**INSTALLER NOTE**

This drinking fountain is furnished with a bubbler and valve including all connecting fittings which are manufactured of completely lead free material. Shut off valve (not furnished) to accept 3/8" O.D. unplated copper tube.

**OPERATION OF QUICK CONNECT FITTINGS**

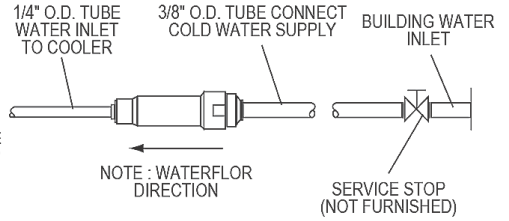
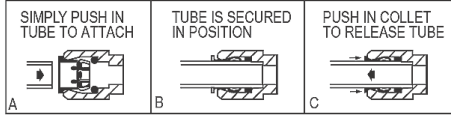

**WARNING:** The free-resistant box must be installed on an interior heated wall where the temperature does not drop below 50° F (10° C). The front of the box must have unobstructed air flow. Failure to maintain the interior wall temperature and the inside of the freeze resistant box above 50° F (10° C) can result in damage to the box which could result in unrestricted water flow.

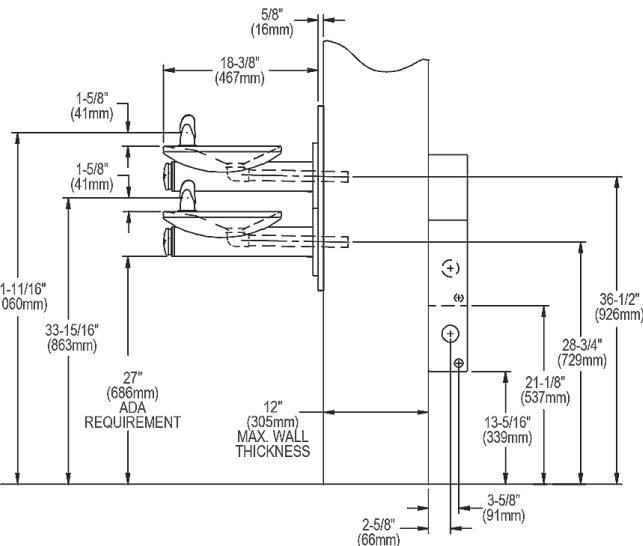
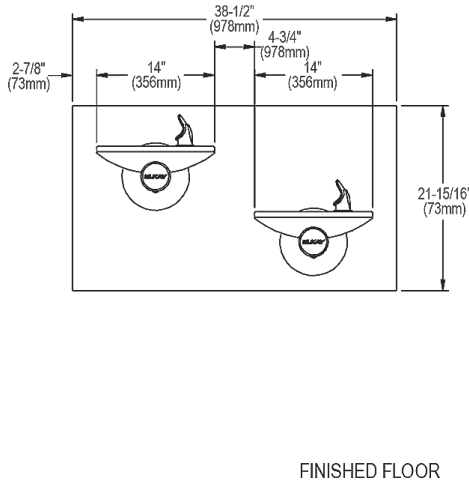
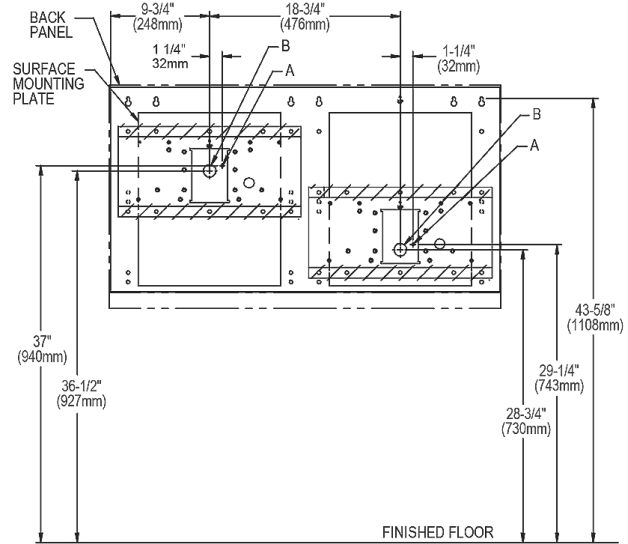
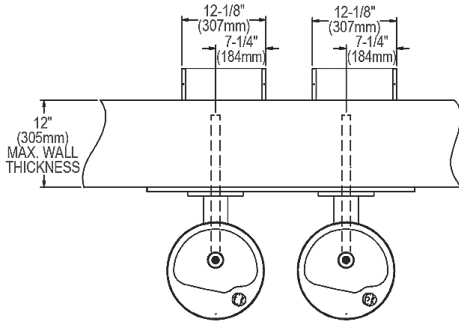

**LEGEND**

- A = 7/8" (22mm) Ø Hole for water supply tube
- B = 1-3/4" (44mm) Ø Hole for waste line

NOTE: REINFORCE WALL IN SHADED AREAS.

\*NOTE: ALL DIMENSIONS ARE TAKEN FROM THE FINISHED FLOOR ON THE SIDE OF THE WALL THAT THE FOUNTAIN IS INSTALL ON.

In keeping with our policy of continuing product improvement, Elkay reserves the right to change product specifications without notice. Please visit [elkay.com](http://elkay.com) for the most current version of Elkay product specification sheets. This specification describes an Elkay product with design, quality, and functional benefits to the user. When making a comparison of other producers' offerings, be certain these features are not overlooked.