

**PRODUCT SPECIFICATIONS**

SwirlFlo<sup>®</sup> Single Fountain Back Plate Non-Filtered Non-Refrigerated Stainless. Furnished with Flexi-Guard<sup>®</sup> Safety Bubbler. Mechanical Front Bubbler Button activation. Product shall be Wall Mount (On Wall), for Indoor applications, serving 1 station(s).

<b>Finish:</b>	Stainless Steel
<b>Power:</b>	No Electrical Required
<b>Bubbler Style:</b>	Flexi-Guard <sup>®</sup> Safety Bubbler
<b>Activation by:</b>	Mechanical Front Bubbler Button
<b>Mounting Type:</b>	Wall Mount (On Wall)
<b>Chilling Capacity:</b>	Non-refrigerated
<b>Dimensions (L x W x H):</b>	19-3/4" x 19" x 21-15/16"
<b>Approx. Shipping Weight:</b>	22 lbs.
<b>Installation Location:</b>	Indoor
<b>No. of Stations Served:</b>	1

**Special Note: Requires In-Wall Carrier MPW101 (sold separately). If rear access is not available front access panels may be required such as ACCESS12X38-5 or AP99**

- Mechanically-Activated unit continues to supply water in event of service disruptions.



**Included with Product:** Fountain with Back Plate,

**Ships in one box.**

A Century of Tradition and Quality. For more than 100 years, Elkay has been making innovative products and providing exceptional customer care. We take pride in offering plumbing products that make life easier, inspire change and leave the world a better place.



**PRODUCT COMPLIANCE**

- ADA & ICC A117.1
- ASME A112.19.3/CSA B45.4
- NSF/ANSI 61 (Q<sub>s</sub>1) & 372 (lead free)
- NSF REG4



Complies with ADA & ICC A117.1 accessibility requirements when installed according to the requirements outlined in these standards. Installation may require additional components and/or construction features to be fully compliant. Consult the local Authority Having Jurisdiction if necessary.

[Installation Instructions \(PDF\) - 97921C](#)

Water Systems are warranted for 12 months from date of installation.

**Warranty pertains to drinking water applications only. Non-drinking water applications are not covered under warranty.**

[Warranty \(PDF\)](#)

PART: \_\_\_\_\_ QTY: \_\_\_\_\_

PROJECT: \_\_\_\_\_



CONTACT: \_\_\_\_\_

DATE: \_\_\_\_\_

NOTES: \_\_\_\_\_

APPROVAL: \_\_\_\_\_

*In keeping with our policy of continuing product improvement, reserves the right to change product specifications without notice. Please visit for the most current version of product specification sheets. This specification describes product with design, quality, and functional benefits to the user. When making a comparison of other producers' offerings, be certain these features are not overlooked.*

Optional Accessories		
<a href="#">EWF172</a>	Universal Filtration Kit (1500-Gallon) <a href="#">Spec Sheet (PDF)</a>	
<a href="#">MPW101</a>	In-wall Mounting Plate for Single-station Non-refrigerated Fountains <a href="#">Spec Sheet (PDF)</a>	
<a href="#">AP99</a>	Access Panel 9" x 9" x 6" <a href="#">Spec Sheet (PDF)</a>	
<a href="#">97446C</a>	Bubbler Kit Vandal-Resistant <a href="#">Spec Sheet (PDF)</a>	

*In keeping with our policy of continuing product improvement, reserves the right to change product specifications without notice. Please visit [www.elkay.com](#) for the most current version of product specification sheets. This specification describes product with design, quality, and functional benefits to the user. When making a comparison of other producers' offerings, be certain these features are not overlooked.*

**INSTALLER NOTE**

This drinking fountain is furnished with a bubbler and valve including all connecting fittings which are manufactured of completely lead free material. Shut off valve (not furnished) to accept 3/8" O.D. unplated copper tube.

**OPERATION OF QUICK CONNECT FITTINGS**

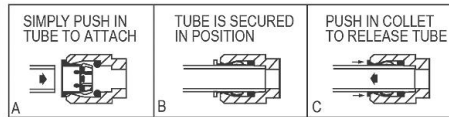

PUSHING TUBE IN BEFORE PULLING IT OUT HELPS TO RELEASE TUBE

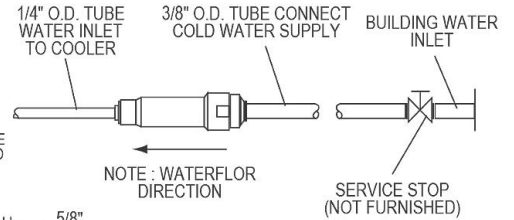

NOTE: WATERFLOW DIRECTION

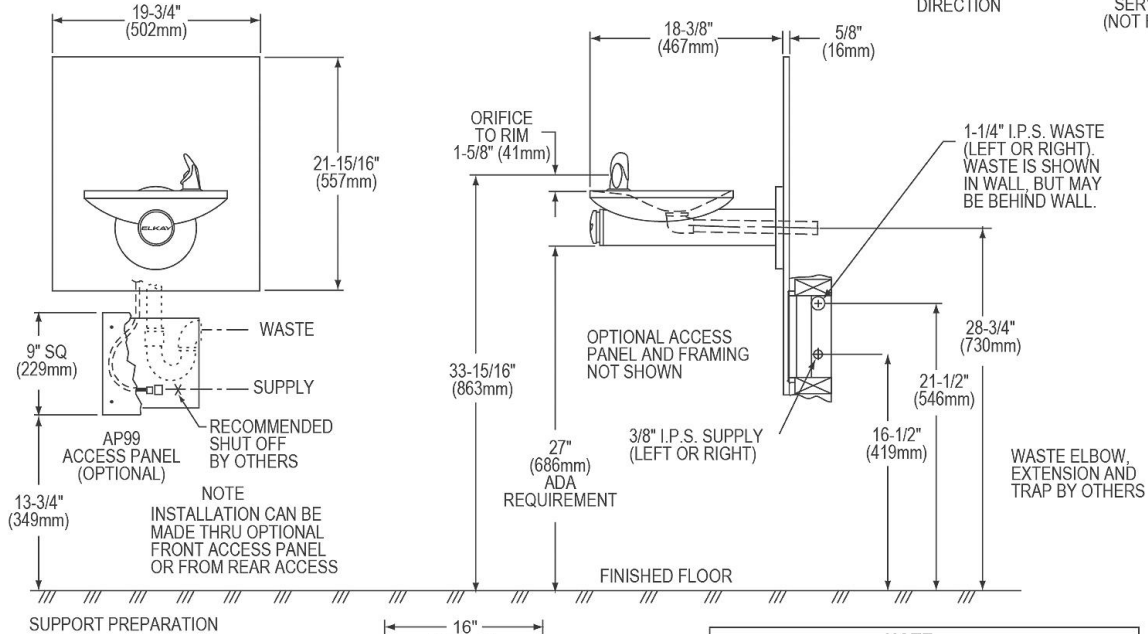

SUPPORT PREPARATION

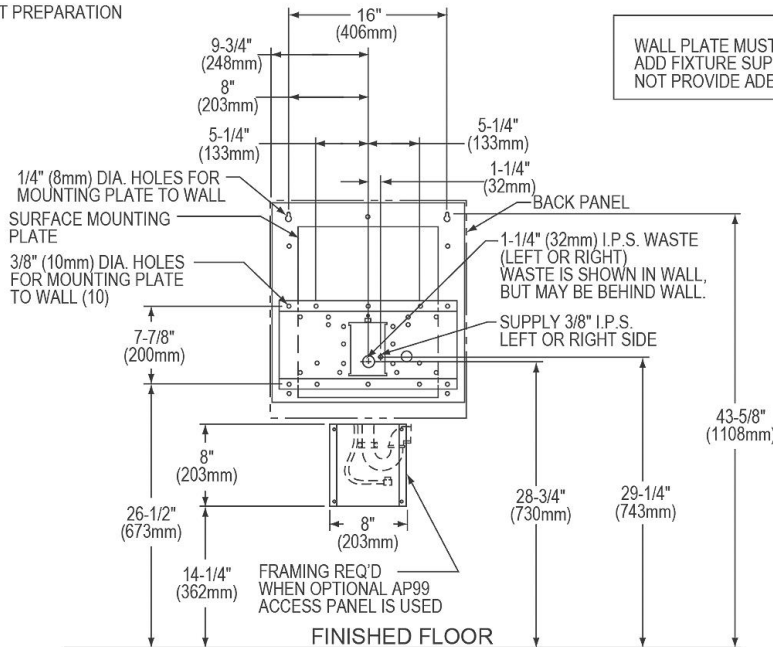

**NOTE**  
WALL PLATE MUST BE SUPPORTED SECURELY. ADD FIXTURE SUPPORT CARRIER IF WALL WILL NOT PROVIDE ADEQUATE SUPPORT.

In keeping with our policy of continuing product improvement, reserves the right to change product specifications without notice. Please visit [www.elkay.com](#) for the most current version of product specification sheets. This specification describes product with design, quality, and functional benefits to the user. When making a comparison of other producers' offerings, be certain these features are not overlooked.