

PRODUCT SPECIFICATIONS

Stainless Steel 14" x 16-1/2" x 42" 18 Gauge Hand Sink with Pedestal Base Foot Valve and Faucet. Sink is manufactured from 18 gauge Stainless Steel with a #4 Finish finish, Center drain placement.



Material:	Stainless Steel
Finish:	#4 Finish
Gauge:	18
Number of Bowls:	1
Sink Dimensions:	14" x 16-1/2" x 42"
Bowl 1 Dimensions:	10" x 12" x 5"
Drain Size:	1-1/2" (38mm)
Drain Location:	Center
Mounting Hardware:	Included

Special Note: Splash Mount, Goose Neck Faucet Included

Included with Product: Pedestal base, foot valve, faucet, and strainer.

A Century of Tradition and Quality.
For more than 100 years, Elkay has been making innovative products and providing exceptional customer care. We take pride in offering plumbing products that make life easier, inspire change and leave the world a better place.

Product Compliance: ASME A112.19.3/CSA B45.4
NSF 2
Faucet: ASME A112.18.1/CSA B125.1
NSF 372 (lead free)
NSF 61 (Q≤1)
Accessory: ASME A112.18.2/CSA B125.2



Sinks are listed by IAPMO® as meeting the applicable requirements of the Uniform Plumbing Code®, International Plumbing Code®, and National Plumbing Code of Canada.

[Clean and Care Manual \(PDF\)](#)
[Installation Instructions \(PDF\) - 2000000714](#)
[Warranty \(PDF\)](#)

PART: _____ QTY: _____

PROJECT: _____

CONTACT: _____

DATE: _____

NOTES: _____

APPROVAL: _____

In keeping with our policy of continuing product improvement, Elkay reserves the right to change product specifications without notice. Please visit elkay.com for the most current version of Elkay product specification sheets. This specification describes an Elkay product with design, quality, and functional benefits to the user. When making a comparison of other producers' offerings, be certain these features are not overlooked.

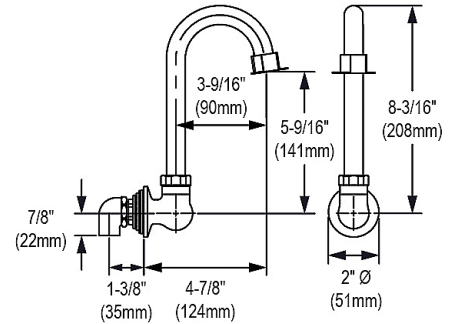
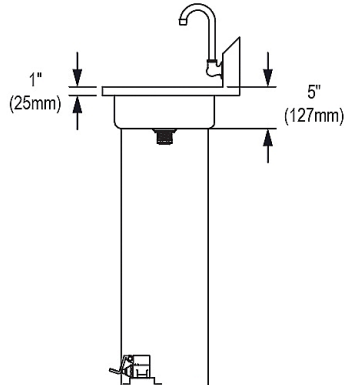
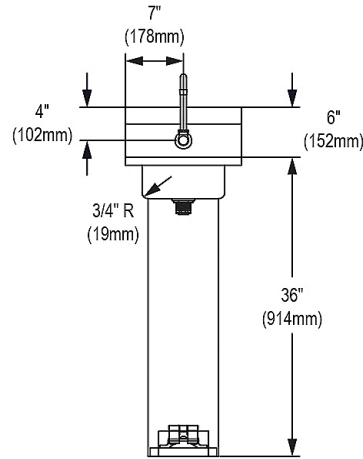
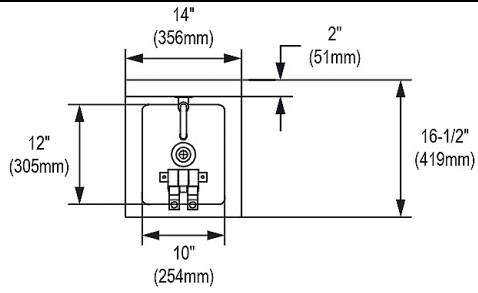

In keeping with our policy of continuing product improvement, Elkay reserves the right to change product specifications without notice. Please visit elkay.com for the most current version of Elkay product specification sheets. This specification describes an Elkay product with design, quality, and functional benefits to the user. When making a comparison of other producers' offerings, be certain these features are not overlooked.