

# ELKAY®

## Installation and Use Manual

### EMASM Surface Mount Bottle Filling Station



### **IMPORTANT**

THIS IS AN INDOOR APPLICATION ONLY!  
ALL SERVICE TO BE PERFORMED BY AN  
AUTHORIZED SERVICE PERSONNEL.

### **TOOLS/ITEMS REQUIRED BUT NOT SUPPLIED**

- SERVICE STOP VALVE WITH 3/8" COMPRESSION OUTLET
- FASTENERS FOR WALL TYPE (8 REQ'D.)
- SLIP JOINT DRAIN UNION OR COMPRESSION CLAMP
- 5/32" HEX-WRENCH

### **Installer**

To assure you install this model easily and correctly, PLEASE READ THESE SIMPLE INSTRUCTIONS BEFORE STARTING THE INSTALLATION. CHECK YOUR INSTALLATION FOR COMPLIANCE WITH ALL PLUMBING, ELECTRICAL AND OTHER APPLICABLE CODES. FOLLOW ALL WARNINGS AND CAUTIONS CAREFULLY. After installation, leave these instructions with the customer for future reference.

### **Warnings**

1. Use with clean, clear, fresh potable drinking water only! Do not use with water that is microbiologically unsafe or of unknown quality without adequate disinfection before the system.
2. These products are designed to operate on 20 to 105 PSI supply line pressure. If inlet pressure is above 105 PSI, a pressure regulator must be installed in supply line. Any damage caused by reason of connecting this product to supply line pressure lower than 20 PSI or higher than 105 PSI is not covered by warranty.

Patent [zurn-elkay.com/patents](http://zurn-elkay.com/patents)

⚠ **WARNING:** Cancer and Reproductive Harm - [www.P65Warnings.ca.gov](http://www.P65Warnings.ca.gov)

⚠ **ADVERTENCIA:** Cáncer y daño reproductivo - [www.P65Warnings.ca.gov](http://www.P65Warnings.ca.gov)

⚠ **AVERTISSEMENT:** Cancer et effets néfastes sur la reproduction - [www.P65Warnings.ca.gov](http://www.P65Warnings.ca.gov)

# ROUGH-IN EMASM ADA STAND-ALONE MOUNTING

**IMPORTANT!****INSTALLATION NOTES:**

- Ensure wall is structurally sound to bear the loads imparted by the Surface Mount Bottle Filler.
- Ambient air temperature limits: 10°C - 38°C (50°F - 100.4°F). Climate Class SN-ST.
- Not suitable for installation in areas where water jets could be used.

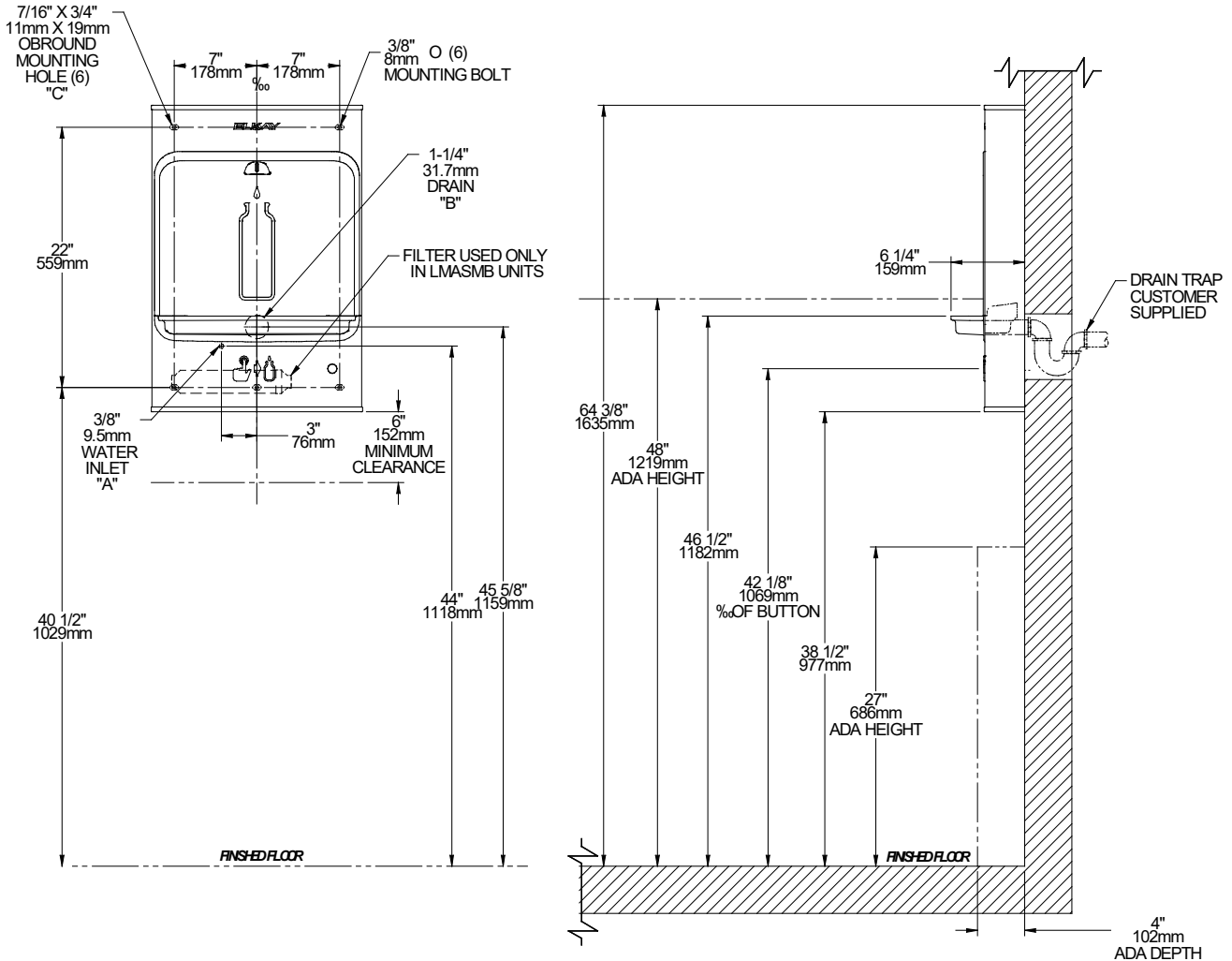
**FIG. 1****LEGEND:**

A = RECOMMENDED WATER SUPPLY LOCATION ; 1/2" IPS MAXIMUM PIPE SIZE. SERVICE STOP VALVE NOT FURNISHED.

B = RECOMMENDED WASTE LOCATION. WASTE SHOWN IN WALL BUT MAY BE BEHIND WALL.

OUTLET 1-1/4" O.D. (TRAP NOT FURNISHED)

C = 7/16" X 3/4" OBROUND MOUNTING HOLES FOR FASTENING BACKPLATE TO WALL.

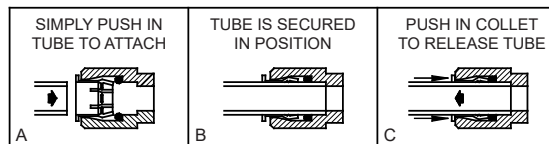
**OPERATION OF QUICK CONNECT FITTINGS**

PUSHING TUBE IN BEFORE PULLING IT OUT HELPS TO RELEASE TUBE

**FIG. 2**

# ROUGH-IN EMASM ADA ABOVE COOLER MOUNTING

**IMPORTANT!****INSTALLATION NOTES:**

- Ensure wall is structurally sound to bear the loads imparted by the Surface Mount Bottle Filler.
- Ambient air temperature limits: 10°C - 38°C (50°F - 100.4°F). Climate Class SN-ST.
- Not suitable for installation in areas where water jets could be used.

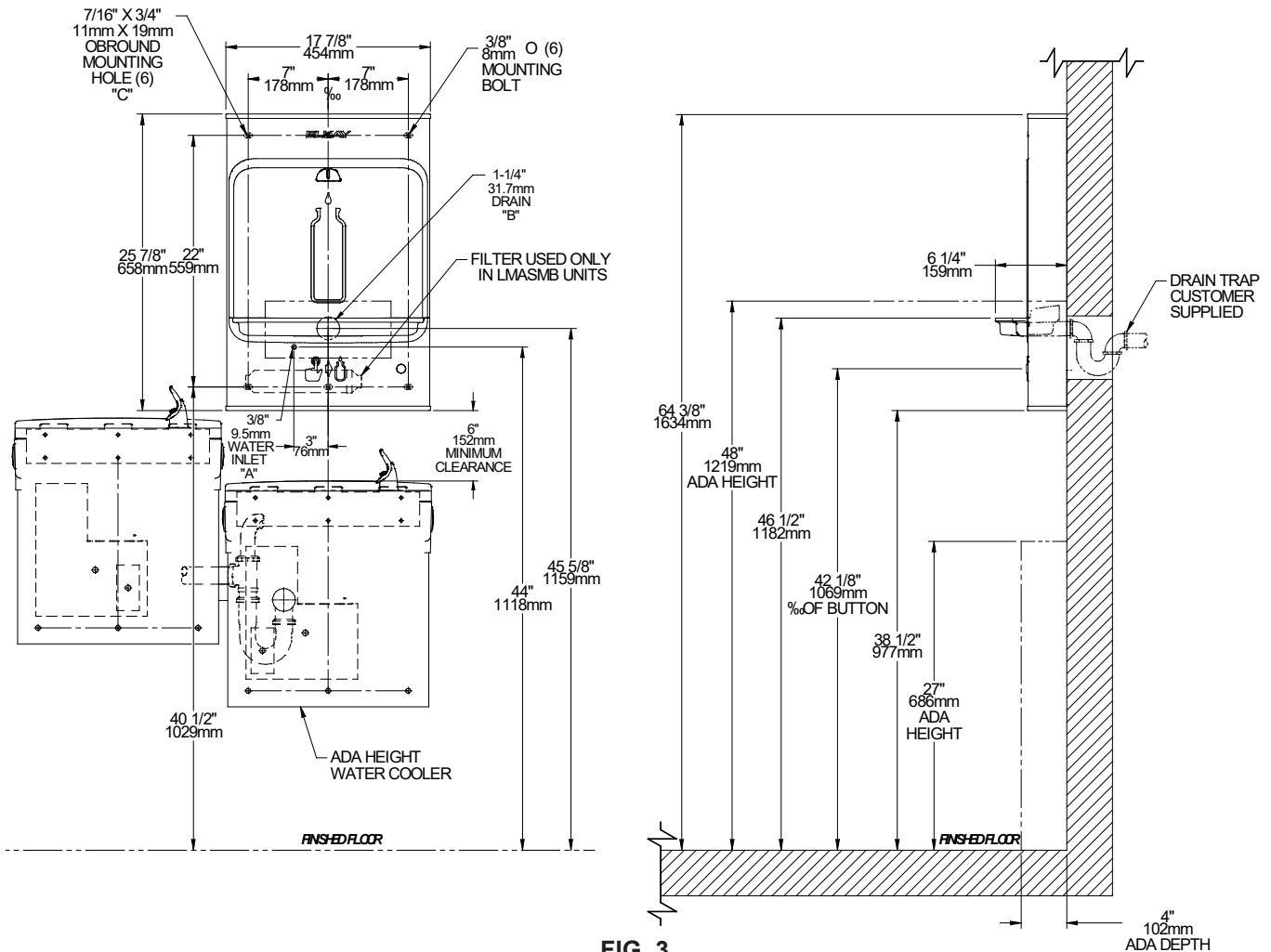
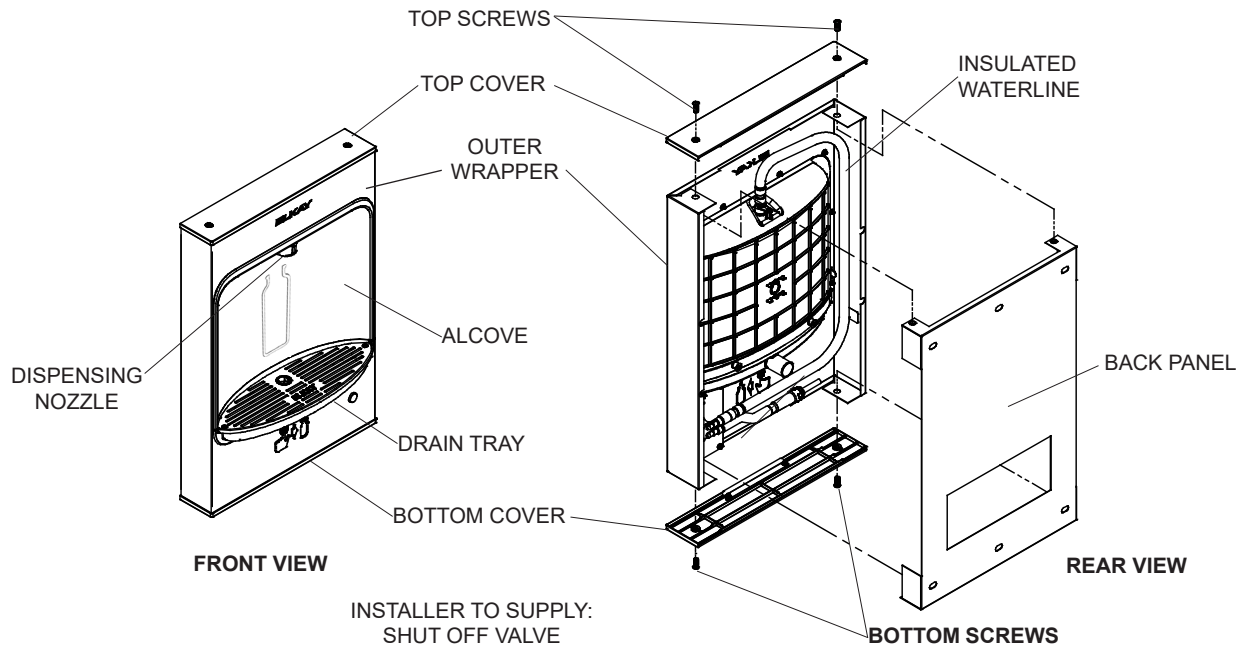

FIG. 3

## INSTALLATION INSTRUCTIONS

### Pre-Installation (reference Rough-In, Fig. 1 and Fig. 3)

1. **Ensure Wall is structurally sound** to bear the loads imparted by the EMASM Bottle Filler (On-Wall Bottle Filler).
2. **Ensure Water Supply Line and Drain Line are sized** and located as specified the Rough-in diagram.
3. **Attach Service Stop Valve (not supplied) to Water Supply line** orienting the 3/8" O.D. female compression outlet horizontally to the left. Purge water line and test for leakage. Correct any leakage.
4. **Ensure package contains the following components:**



### EMASM UNIT SHOWN

### Wall Mounting (reference Rough-In, Fig. 1 and Fig. 3)

1. **Remove Top Cover from Bottle Filler** by removing two (2) screws from top of unit. Use a 5/32" hex wrench (not supplied).
2. **Remove Bottom Cover from Bottle Filler** by removing two (2) screws from bottom of unit. Use a 5/32" hex wrench (not supplied).
3. **With the Top and Bottom Covers removed**, the Back panel is now free to be removed from Bottle Filler.
4. **Fasten Back Panel to structurally secure wall** through five 7/16" obround holes with fasteners appropriate for wall type. Locate Back Panel as specified in Rough-In.
5. **Ensure Back Panel is not obstructed** by the roughed-in Water and Drain Lines. If Back Panel is prevented from seating properly, reposition Water and/or Drain Lines slightly until the Bottom Cover fits easily.
6. **Before hanging the On-Wall Bottle Filler**, ensure the Insulated Waterline is routed inside of the Wrapper If outside the Wrapper, reposition to inside or else the unit cannot be installed properly.
7. **Hang the Bottle Filler onto the Back Panel**, aligning two tabs into the top of the Back Panel.
8. **Secure Bottle Filler to Back Panel** by replacing Top Cover on top of unit and fastening with two (2) supplied screws.
9. **Replace the Bottom Cover** on bottom of the unit and fasten in place with two (2) supplied screws.

**Plumbing Connections**

- Ensure lines and ports remain clean and free of contaminants during assembly.
- Purge each component if necessary.
- To ensure quick-connect connections seal properly, follow instructions per Figure 2, Page 2.

**Connect Plumbing Lines**

1. **Connect water supply line to unit:**
2. **Connect the 3/8" O.D. Copper tube** from the in-line strainer to the 3/8" to the Service Stop Valve.
3. **Connect the 1-1/4" O.D. Drain Tray Outlet** to the in-wall Drain Line using a Slip Joint Drain Union or compression clamp (not supplied). Tighten all connections water tight.
4. **Turn water supply on**, inspect for leaks and correct any leaks before continuing.

**Instruction for Use**

1. **Place container under the dispenser nozzle** and depress the actuator button. Hold until container is filled to the level desired.
2. **To stop water flow, release actuator button.** Pull container away from dispenser nozzle.

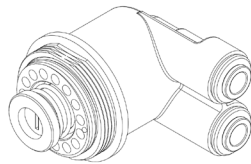
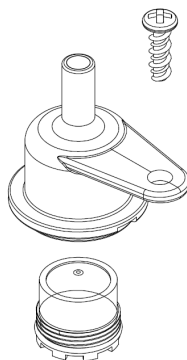
**REGULATOR****AERATOR****REPLACEMENT PARTS**

| PART NO.             | DESCRIPTION                                 |
|----------------------|---|
| 1000001673<br>98546C | 1.0 GPM REGULATOR KIT- EMASM<br>AERATOR KIT |



**0000001496**

PRINTED IN U.S.A.

FOR PARTS, CONTACT YOUR LOCAL DISTRIBUTOR OR CALL 1.800.834.4816  
REPAIR SERVICE INFORMATION TOLL FREE NUMBER 1.800.260.6640

ELKAY MANUFACTURING COMPANY • 1333 BUTTERFIELD ROAD • DOWNERS GROVE, IL 60515 • 630.574.8484 • [www.elkay.com](http://www.elkay.com)