

### PRODUCT SPECIFICATIONS

Bi-Level Filter Maintenance Kit with High Capacity Filter. Overall dimensions are 17-9/16" x 13-3/4" x 10-9/16".

<b>Special Features:</b>	Filtered
<b>Mounting Type:</b>	Wall Mount (On Wall)
<b>Finish:</b>	Stainless Steel
<b>Dimensions:</b>	17-9/16" x 13-3/4" x 10-9/16"
<b>Shipping Weight:</b>	8 lbs.
<b>Flow Rate:</b>	1.5 GPM (5.6 L/m)
<b>Capacity:</b>	
<b>Temperature:</b>	40-100°F (4-38°C)
<b>Initial Pressure Drop:</b>	2-5 PSI (14-34 kPa)
<b>Maximum Pressure:</b>	105 PSI (724 kPa)
<b>Minimum Pressure:</b>	20 PSI (138 kPa)
<b>Water Inlet:</b>	3/8" (9.5mm) O.D. tube
<b>Water Outlet:</b>	1/4" (6.4mm) O.D. tube

**Special Note:** Kit includes left-side access cooler wrapper only. Right side stainless steel cooler wrapper for bi-level units sold separately. Order to pair with EZFMTLP (#1000000888).

- Cooler side panel provides convenient access to filter, water shut-off valve, and power supply without removing entire wrapper
- Two alignment pins on the panel make it easy to attach
- At least 36 in. of space on left side of drinking water unit is recommended
- Retrofit kit is compatible with Elkay EZ/LZ bi-level filtered coolers and bottle filling stations
- WaterSentry 51600C 6,000-gallon filter is tested and certified to NSF 42 and 53 for the reduction of lead, Class 1 particulate, chlorine taste and odor
- Kit includes cooler wrapper with side access panel, 51600C water filter, security Torx bit and screws



**Included with Product:** One stainless steel wrapper with side access panel (for bi-level stations) and filter

A Century of Tradition and Quality. For more than 100 years, Elkay has been making innovative products and providing exceptional customer care. We take pride in offering plumbing products that make life easier, inspire change and leave the world a better place.

[Installation Instructions \(PDF\) - 2000000888](#)

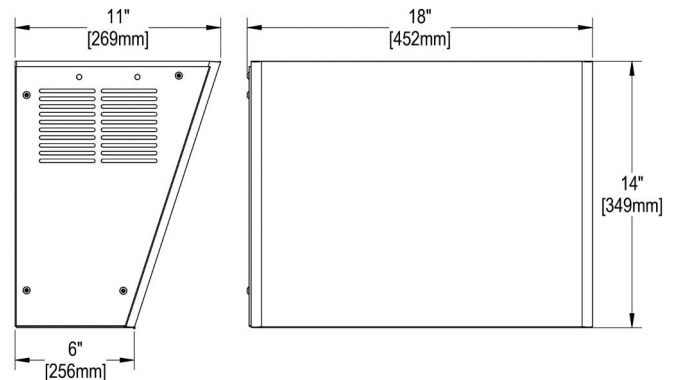

PART: \_\_\_\_\_ QTY: \_\_\_\_\_

PROJECT: \_\_\_\_\_

CONTACT: \_\_\_\_\_

DATE: \_\_\_\_\_

NOTES: \_\_\_\_\_

APPROVAL: \_\_\_\_\_

*In keeping with our policy of continuing product improvement, Elkay reserves the right to change product specifications without notice. Please visit [elkay.com](http://elkay.com) for the most current version of Elkay product specification sheets. This specification describes an Elkay product with design, quality, and functional benefits to the user. When making a comparison of other producers' offerings, be certain these features are not overlooked.*