

Installation Instructions

Freeze Resistant Package

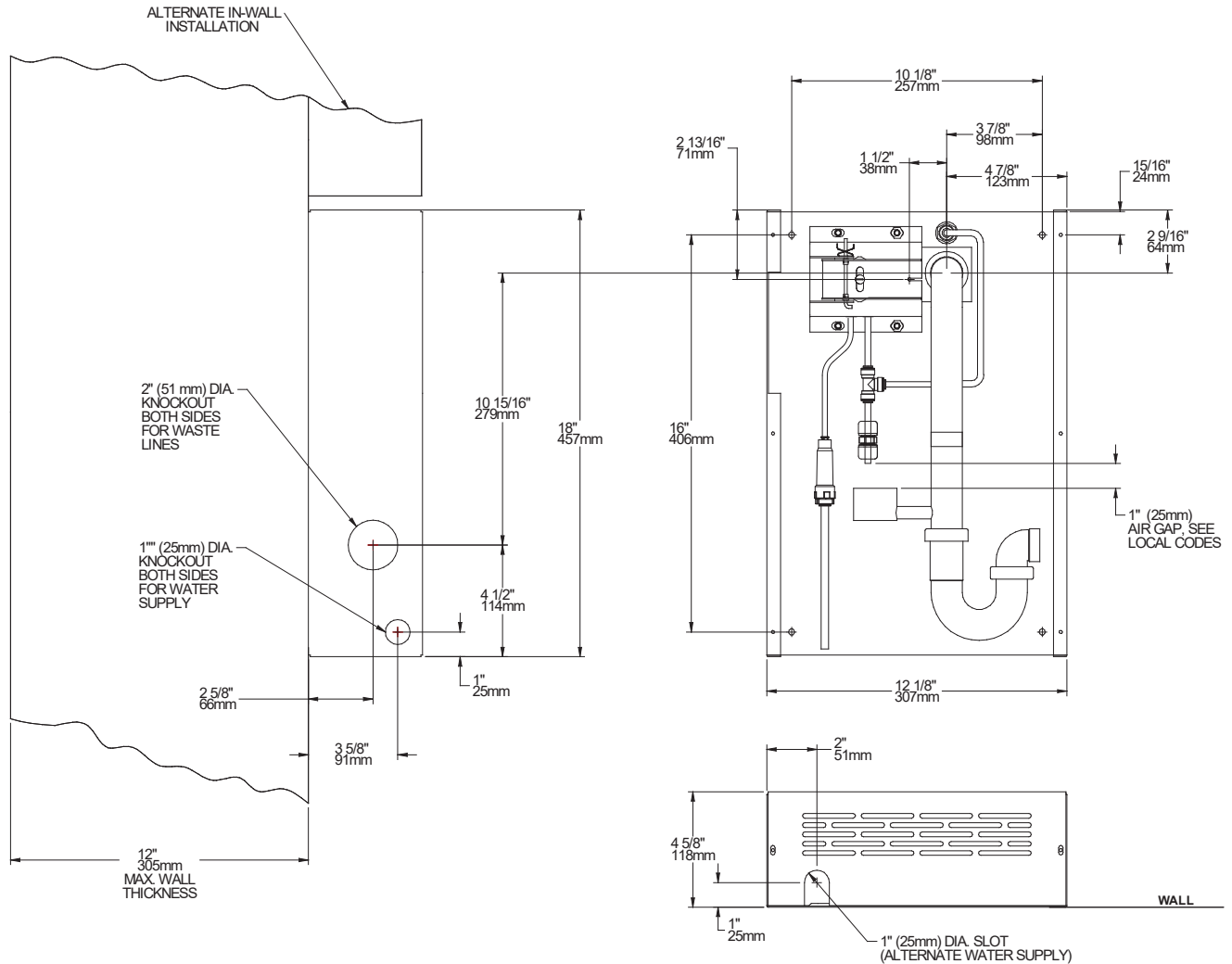

FIG. 1

WARNING: This Freeze Resistant Package must be installed on an interior heated wall. The front of the box must have unobstructed air flow. Failure to maintain the interior wall temperature and the inside of the Freeze Resistant Package above 50° F (10° C) can and will cause damage to the Freeze Resistant Package. This damage can result in bursting and rupturing of interior plumbing which will result in uncontrollable water flow and flooding of the area. Rough-In dimensions will vary depending upon the type of fountain that this package is installed with. Dimensions shown are for reference only.

CABLE SHEATH ADJUSTMENT

To Increase Free Play



To Reduce Free Play

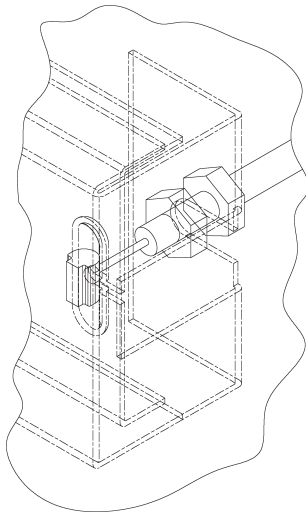
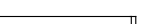

FIG. 2

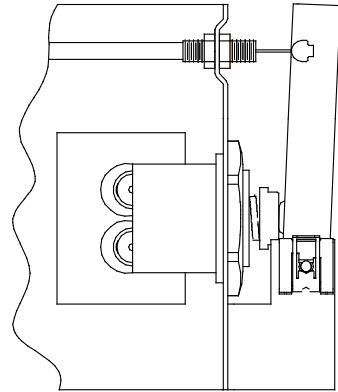

FIG. 3

Note: Fountain Style May Vary

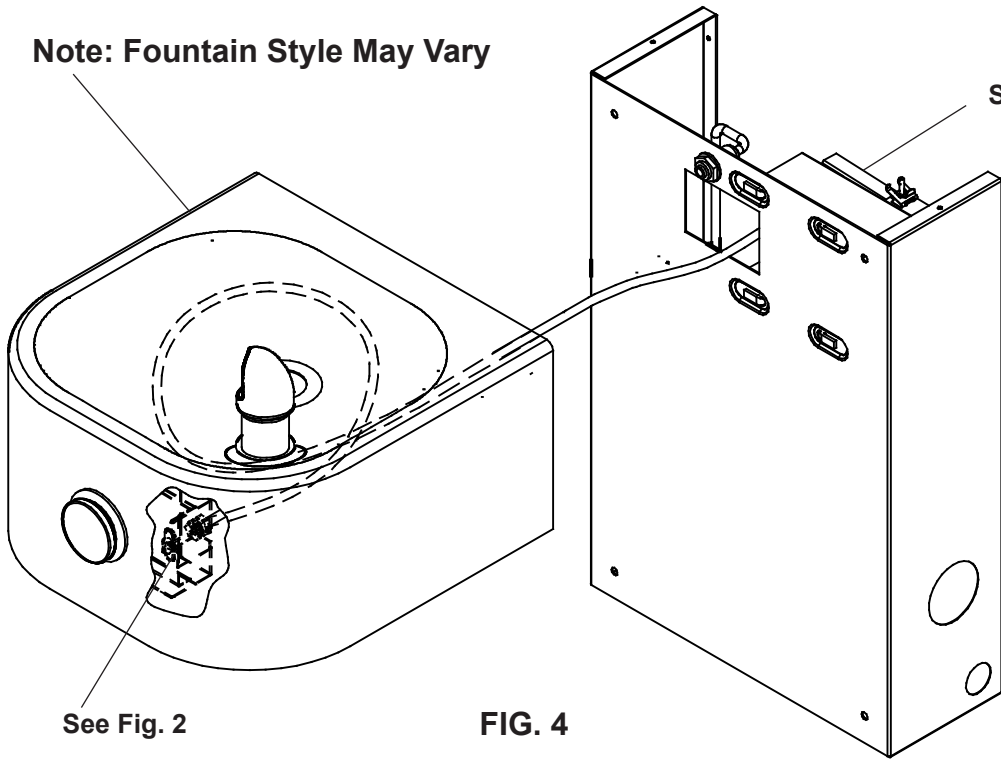

FIG. 4

See Fig. 2

See Fig. 6

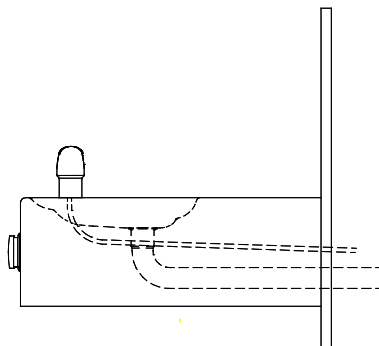

FIG. 5

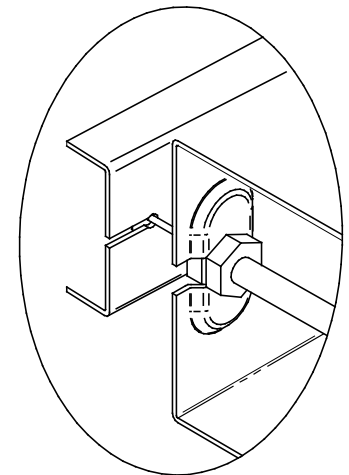

FIG. 6

INSTALLATION INSTRUCTIONS

The freeze resistant package must be mounted on an interior wall in a heated area. The room temperature of the interior heated area must be 50° F (10° C) or higher. The freeze resistant package may be surface or recessed mounted. If recess mounted the surface of the cover must be flush with the interior wall surface. The package is furnished with screws for mounting the cover to the box. If the box is recess mounted, do not fasten the top and bottom of the cover to the box. Use the holes on the front only.

1. Assemble the operating cable to the fountain bracket. (Fountain should be mounted to exterior wall). The adjustment nuts should be adjusted as per the fountain's instructions. Create a loop in the cable and thread the free end of the cable through the wall into the freeze resistant box.
2. Connect free end of operating cable to the valve-operating bracket in the freeze resistant box.
3. Remove cable free play by adjusting the jam nuts on the ends of the operating cable. See Figure 3.
4. Connect water line from fountain bubbler into freeze resistant box. The connection to the box uses a quick connect water fitting. Position the water line, in the fountain, to drain back into interior mounted box. Any water left standing, in the exterior line, can freeze. See Figure 5.

To insert tubing, push tube straight into fitting until it reaches a positive stop. To remove tubing from the fittings, relieve water pressure, push in on dark gray collar while pulling out on the tubing. See Figure 8.

5. Connect drain and water supply lines to the freeze resistant fountain. Refer to Figure 1 for component positions. Inline strainer must be used on the inlet water line. See Figure 7.

Start-up

1. Turn on building water supply and check all connections for leaks. Repair as required.
2. Stream height is factory set at 35 PSI. If stream height needs to be changed adjust screw on regulator, behind regulator pivot bracket. See Figure 11. Clockwise adjustment raises stream height, counter clockwise adjustment will lower stream.
3. Adjust operating cable as required. Cable system should have a minimal amount of free play to allow for proper valve operation. If the system is too tight the valve will stay in the on position creating constant water flow. Too much free play will result in non-operation of the valve with the push-buttons.
4. Note: Water from the drain back tube will continue to run while the valve is actuated. (Reference Item 6).
5. After cable system is adjusted properly stuff flexible insulation into any openings between the outside wall and the interior box.
6. Recheck all connections. If all connections are leak free replace cover(s) on the freeze resistant box(es) and fountain(s).

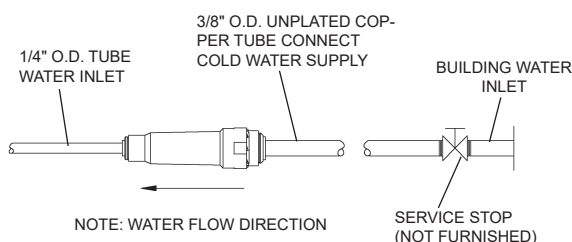

FIG. 7

OPERATION OF QUICK CONNECT FITTINGS

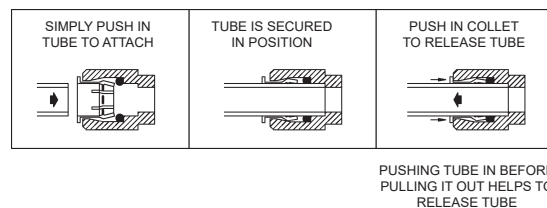

FIG. 8

PARTS LIST

ITEM NO.	PART NO.	DESCRIPTION
1	98733C	KIT - REGULATOR/HOLDER/NUTS
2	27312C	COVER - BODY
3	98858C	KIT - FREEZE BOX REGULATOR BRKTS/ ROD/BUSHINGS/CLIP
4	70682C	FITTING - TEE 1/4"
5	27984C	FREEZE RESISTANT BODY ASSY/SCREW
6	98859C	KIT - FREEZE BOX CHECK VALVE/O-RING
7	98860C	KIT - FREEZE BOX WASTE LINE
8	55996C	STRAINER
NS	75582C	OPERATING CABLE

NS - NOT SHOWN

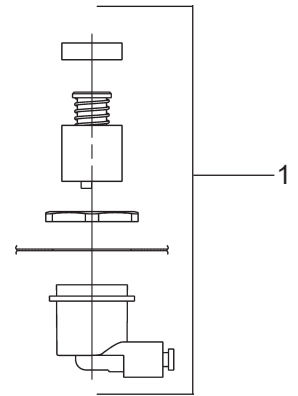

FIG. 9

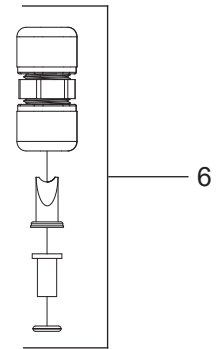

FIG. 10

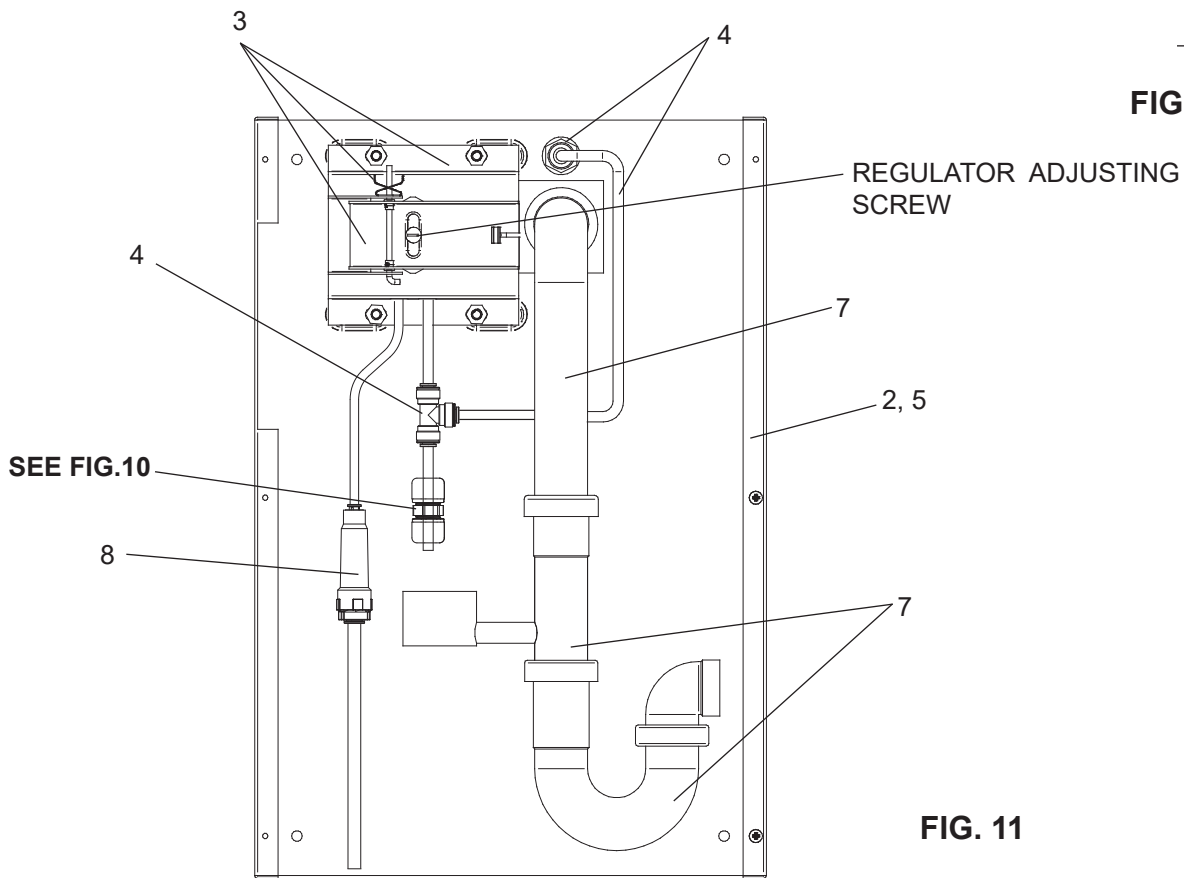

FIG. 11

FOR PARTS, CONTACT YOUR LOCAL DISTRIBUTOR OR CALL 1.800.834.4816

REPAIR SERVICE INFORMATION TOLL FREE NUMBER 1.800.260.6640

PRINTED IN U.S.A.

ELKAY MANUFACTURING COMPANY • 1333 BUTTERFIELD ROAD SUITE 200 • DOWNERS GROVE, IL 60515 • 630.574.8484 • www.elkay.com