

PRODUCT SPECIFICATIONS

ezH2O® VR Mechanical Bottle Filling Station w/Bi-Level Integral Soft Sides® Fountain Filtered Non-Refrigerated Stainless. Features shall include Ambient Water, Filtered, Includes Back Plate, Laminar Flow, Mechanically Activated, New Offering, Vandal Resistant. Furnished with Vandal Resistant bubbler. Mechanical Bottle Filler Button with Mechanical Front Bubbler Button activation. Product shall be Wall Mount (In-Wall Frame/Plate), for Indoor + Outdoor applications, serving 2 station(s).

Special Features:	Ambient Water, Filtered, Includes Back Plate, Laminar Flow, Mechanically Activated, New Offering, Vandal Resistant
Finish:	Stainless Steel (S)
Power:	No Electrical Required
Bubbler Style:	Vandal Resistant
Activation by:	Mechanical Bottle Filler Button with Mechanical Front Bubbler Button
Mounting Type:	Wall Mount (In-Wall Frame/Plate)
Chilling Capacity:	Non-refrigerated
Dimensions (L x W x H):	38-1/2" x 19-3/8" x 34-5/8"
Installation Location**:	Indoor + Outdoor
No. of Stations Served:	2
**When used in non-temperature controlled environments, unit(s) must be adequately winterized and/or protected from extreme heat to prevent damage where climates dictate.	

Special Note: When used in non-temperature-controlled environments, unit(s) must be adequately winterized and/or protected from extreme heat to prevent damage where climates dictate. The filters are certified for water temperatures up to 100°F.

- Mechanically-Activated unit continues to supply water in event of service disruptions.
- Standard Filter Included: Filter is tested and certified to NSF/ANSI 42, 53, 372 and 401 for the reduction of lead, microplastics, Class 1 particulate, cysts, and chlorine taste and odor. 3,000 gallon capacity or 1 year after installation.
- Laminar flow provides clean fill with minimal splash.



Included with Product: Bottle Filler (EBWDCM0SSC), Fountain Only (EDFPV217LWS), Frame (MFWS202)

▼ Ships in multiple boxes.

A Century of Tradition and Quality. For more than 100 years, Elkay has been making innovative products and providing exceptional customer care. We take pride in offering plumbing products that make life easier, inspire change and leave the world a better place.



PRODUCT COMPLIANCE

- ADA & ICC A117.1
- ASME A112.19.3/CSA B45.4
- NSF/ANSI 42, 53, 61 (Q≤1), 372 (lead free), & 401



Complies with ADA & ICC A117.1 accessibility requirements when installed according to the requirements outlined in these standards. Installation may require additional components and/or construction features to be fully compliant. Consult the local Authority Having Jurisdiction if necessary.



- [Installation Instructions \(PDF\) - 2000001276](#)
- [Installation Instructions \(PDF\) - 2000001464](#)

Water Systems are warranted for 12 months from date of installation. **Warranty pertains to drinking water applications only. Non-drinking water applications are not covered under warranty.**

[Warranty \(PDF\)](#)

PART: _____ QTY: _____
 PROJECT: _____
 CONTACT: _____
 DATE: _____
 NOTES: _____
 APPROVAL: _____

In keeping with our policy of continuing product improvement, Elkay reserves the right to change product specifications without notice. Please visit elkay.com for the most current version of Elkay product specification sheets. This specification describes an Elkay product with design, quality, and functional benefits to the user. When making a comparison of other producers' offerings, be certain these features are not overlooked.

Optional Accessories		
ACCESS12X38-5	Stainless Steel Access Panel for Bi-Level Architectural Fountains Spec Sheet (PDF)	
51300C	WaterSentry® Lead + Microplastics NSF/ANSI Certified 3000 Gal 12 Month Filter Spec Sheet (PDF)	
97258C	Cane Apron for Contour™ & Soft Sides® Models Black Spec Sheet (PDF)	

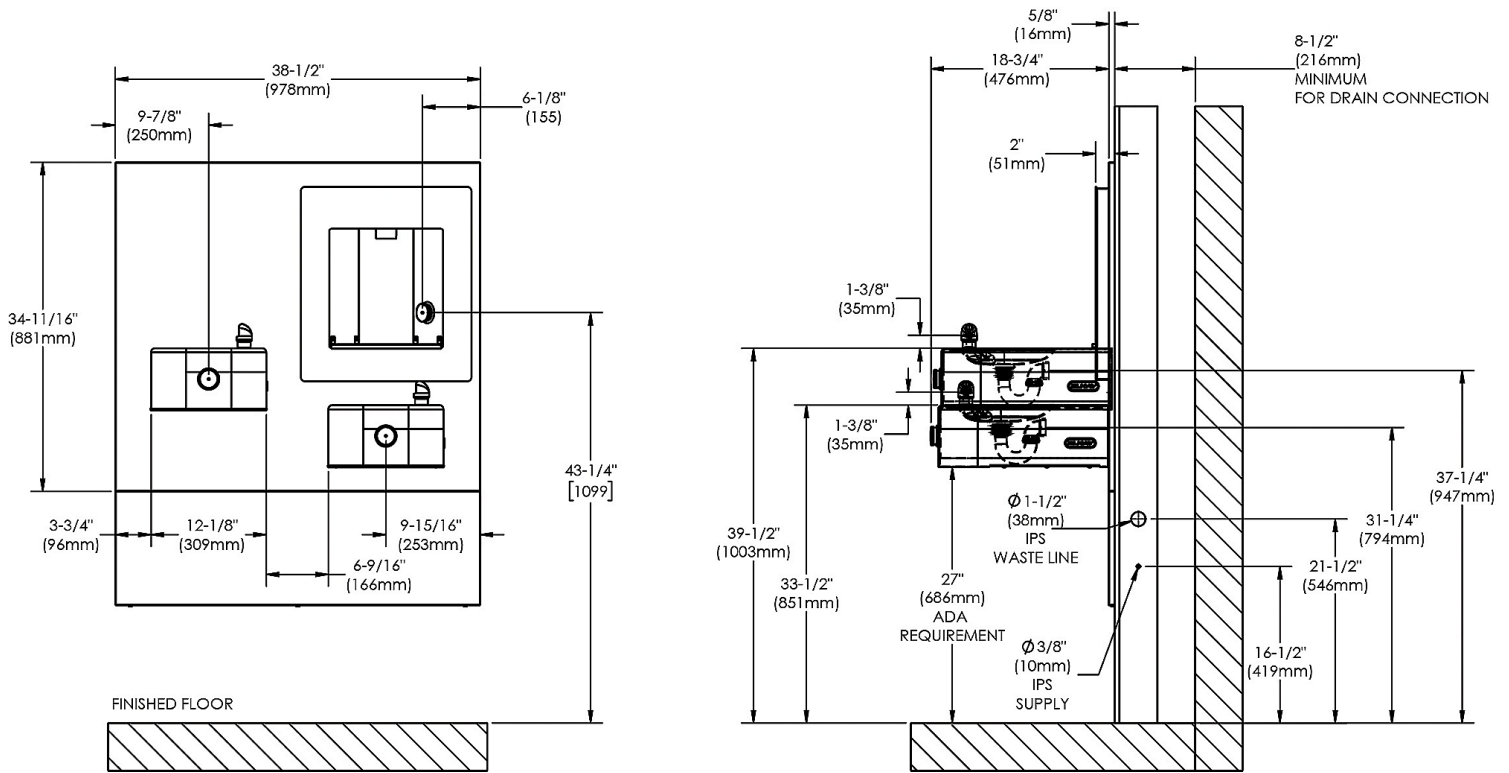

In keeping with our policy of continuing product improvement, Elkay reserves the right to change product specifications without notice. Please visit elkay.com for the most current version of Elkay product specification sheets. This specification describes an Elkay product with design, quality, and functional benefits to the user. When making a comparison of other producers' offerings, be certain these features are not overlooked.