

ELKAY®

Enhanced

INSTALLATION & USE MANUAL

LZ™ Series Bottle Filling Stations & Coolers SMART CONNECTED-READY



Pre-installation steps

Install Zurn Gateway and Register Product in plumbSMART

1. Install Zurn Gateway (required and sold separately) per the gateway instructions manual, if an existing gateway is not within communication range.
2. Be sure the gateway is powered on and connected (per gateway installation instructions) prior to installing your bottle filler. Serial number located on back of the Gateway, is required to register the gateway to your tenant.
3. If you have not already set up an tenant account and your administrator access, request at 844-987-67 37 or zurnconnectedproducts@zurn.com
4. Log into plumbsmart.zurn.com
5. Register Connected product in plumbSMART using plumbSMART Registration ID located on plumbSMART ID Registration Label, (See Fig. 8a, Pg. 6). (Watch How-To videos to get started. Located in the support section inside the portal.)

Patent zurn-elkay.com/patents

⚠ **WARNING:** Cancer and Reproductive Harm - www.P65Warnings.ca.gov

⚠ **ADVERTENCIA:** Cáncer y daño reproductivo - www.P65Warnings.ca.gov

⚠ **AVERTISSEMENT:** Cancer et effets néfastes sur la reproduction - www.P65Warnings.ca.gov

INSTRUCTIONS FOR REMOVING WRAPPER

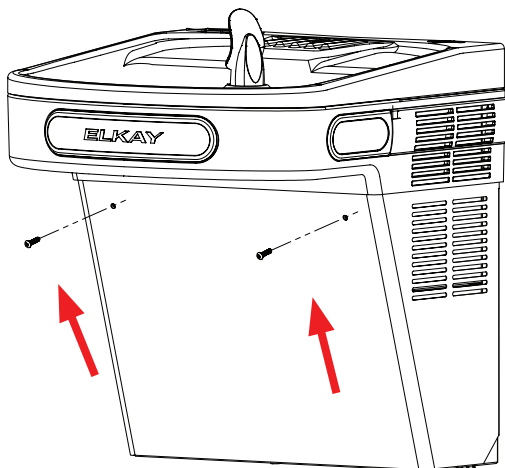

Fig. B(i)

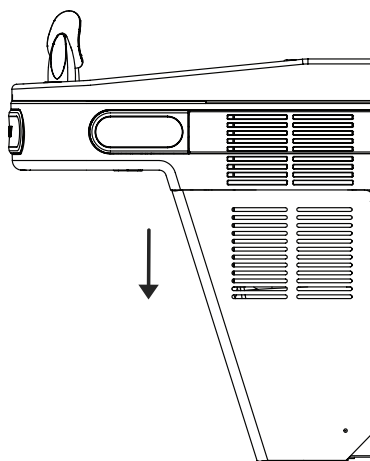
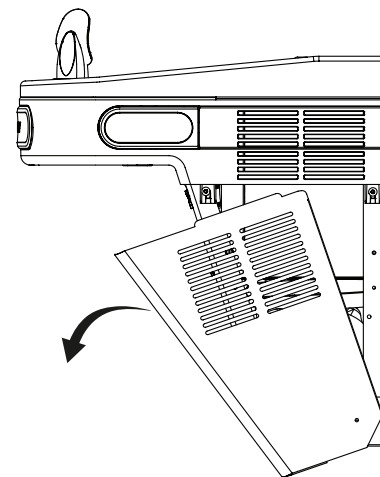

Fig. B(ii)



- 1) Remove the two security screws (size T25) from the front panel. (see Fig B(i))
NOTE: SCREW THREADS INTO BUSHING WHILE ANGLED. DO NOT ATTEMPT TO THREAD SCREW INTO BUSHING HORIZONTALLY.
- 2) Gently pull the wrapper down and rotate the wrapper to a downward position (see Fig B(ii)).
- 3) To remove the wrapper, hold each side and gently pull wrapper up and out of pivoting bracket (see Fig B(iii)).

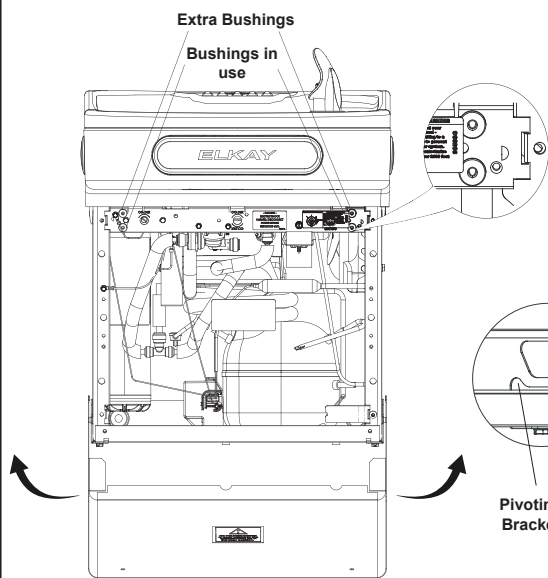

Fig. B(iii)

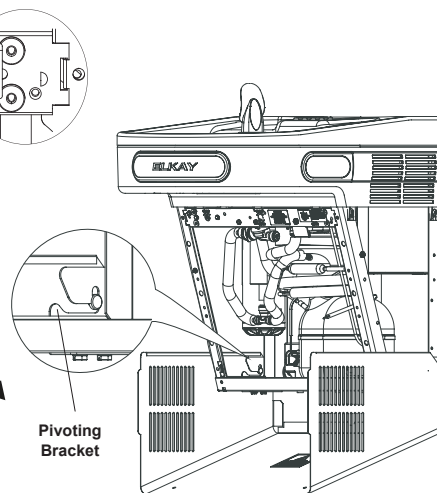

Fig. B(iv)

Fig. B(v)

CAUTION: WRAPPER DROPS AND SWINGS WHEN SECURITY SCREWS ARE REMOVED.

CAUTION: DO NOT LEAN ON WRAPPER.

CAUTION: DO NOT USE POWER TOOL TO TIGHTEN. DO NOT OVERTIGHTEN.

NOTE:

1. Ensure that there are no plumbing or external objects below the wrapper in the specified dimension. The specified (3.27") minimum distance is required for the wrapper to swing out (see Fig B(iv)).
2. Removing the wrapper from the pivoting bracket when servicing the unit is recommended. The wrapper may be left in place for quick serviceability (see Fig B(iii)).
3. When re-attaching wrapper, ensure each side of wrapper is engaged to pivoting bracket (see Fig B(v)).
4. Once the wrapper is in place, rotate wrapper up and under the shroud. Ensure thru holes on wrapper are aligned with plastic bushing threads on the frame prior to engaging security screws. Ensure screw is angled relative to the ground and perpendicular to wrapper surface prior to engagement. Hand tighten prior to using hand tool to avoid cross-threading.
5. Four plastic bushings are located in the cross brace of the frame. The lower two bushings align with wrapper holes and the top two bushings are extras in case of replacement (see Fig B(iii)).

HANGER BRACKET INSTALLATION

- 1) Remove hanger bracket fastened to back of cooler by removing one (1) screw.
- 2) Mount the hanger bracket as shown in Figure 1 (Pg. 2).

NOTE: Hanger Bracket **MUST** be supported securely. Add fixture support carrier if wall will not provide adequate support. Anchor hanger securely to wall using all six (6) 1/4 in. dia. mounting holes.

IMPORTANT: 5-7/8 in. (150mm) dimension from wall to centerline of trap must be maintained for proper fit.

INSTALLATION OF COOLER

- 3) Hang the cooler on the hanger bracket. Be certain hanger bracket is engaged properly in the slots on the cooler back as shown in Figure 1 (Pg. 2).
- 4) Refer Fig B(i) to B(iv), Pg. 3 for wrapper removing instructions.
- 5) Secure cooler frame to wall by installing (2) screws and washers (not supplied) in lower holes. (See Fig. 2, Pg. 5). Make sure the screws engage in a structural member.
- 6) Connect the supply water to the filter inlet tube.
- 7) Install trap.

IMPORTANT: If it is necessary to cut the drain, loosen the screw at the black rubber boot and remove tube, check for leaks after re-assembly.

BOTTLE FILLER INSTALLATION

- 8) Remove two (2) mounting screws with 5/32" Allen wrench holding bottle filler to wall mounting plate (See Fig.8, Pg. 6). Note do not discard mounting screws, they will be needed to secure bottle filler to wall mounting plate.
- 9) Remove wall mounting plate from Bottle Filler (see Fig 8, Pg. 6). Place wall mounting plate against wall on top of basin. Center the wall mounting plate side to side with the basin. Mark the six (6) mounting holes with a pencil. Place tape over wiring harness connection on top of cooler to prevent debris from falling into Connection.
- 10) Remove wall mounting plate from wall. **NOTE:** Mounting plate **MUST** be supported securely. Add fixture support carrier if wall will not provide adequate support.
- 11) Install wall mounting plate to wall using six (6) 7/16" obround mounting holes (mounting bolts not included) (See Fig.8, Pg. 6). Use appropriate fasteners for your wall type.
- 12) Install gasket on bottom of bottle filler tower with gasket support bracket & (2) screws. (See Fig. 4, Pg. 5).
- 13) Route 3/8" tubing through the opening in the bottle filler gasket and plug into bulkhead fitting in basin. Route the wiring harness through the gasket and plug into the connector on the top of the basin. Water line should be cut to length prior to attaching to bulkhead fitting.
- 14) Place bottle filler on four (4) hooks on the mounting plate installed on wall. Make sure round boss in gasket fits in hole of basin. (See Fig. 8, Pg. 6).
- 15) Plug electrical cord into outlet on wall.
- 16) Remove filter from carton, remove protective cap, attach filter to filter head by firmly inserting into head and rotating filter clockwise. Ensure that front facing label can be read when filter is installed. (See Fig. 11, Pg. 8).
- 17) Turn water supply on and inspect for leaks in both cooler and bottle filler. Fix all leaks before continuing.
- 18) Reinstall two mounting screws from first step (See Fig. 8, Pg. 6). Caution, do not over tighten screws.
- 19) Once power is applied to the cooler the BLUE LED light will illuminate on the bottle filler showing good filter status along with the LCD Bottle Counter.
- 20) Verify proper dispensing by placing cup, hand, or any opaque object in front of sensor area and verify water dispenses. **NOTE:** The first initial dispenses might have air in line which may cause a sputter or hazy appearance of water. This will be eliminated once all air is purged from the line. Run water and flush filter to purge air and fine carbon particles from filter before use. Visit elkay.com/filtration for additional details.
- 21) Once unit tests out, install Lower Panel back on water coolers.
- 22) When re-attaching wrapper, push wrapper up and under the shroud. Make sure wrapper and bushing holes are aligned prior to inserting screw. Units are now ready for use.

Note: Danger! Electrical shock hazard. Disconnect power before servicing unit.

Instructions For Replacing Filters

- 1) Refer Fig B(i) to B(iv), Pg. 3 for wrapper removing instructions.
- 2) Turn off water supply; dispense water to relieve pressure.
- 3) Disconnect electrical power by unplugging unit's power cord.
- 4) Turn used filter counterclockwise 1/4 turn to remove from filter head.
- 5) Remove cap from new filter and use to seal used filter.
- 6) Insert new filter into existing filter head and turn fully clockwise. Make sure you can read the label on the front of the filter once it is installed. (See Fig.11, Pg. 8).
- 7) Connect electrical power by plugging in unit's power cord.
- 8) Turn on water supply and flush filter to purge air and fine carbon particles from filter before use. Visit elkay.com/filtration for additional details. Also run water through bottle filler until all air is removed and water flow is clear.

Note: Filter status light will automatically reset once new filter is installed.

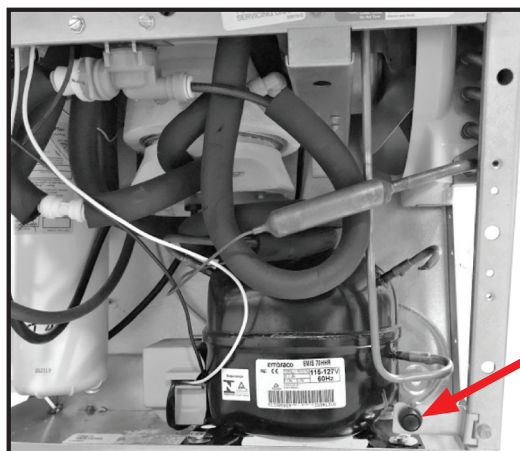

Fig. A

Instructions To Access Programming Button

- 1) Remove lower cover on refrigerated unit by removing (2) screws (see Fig 7, Pg. 6) and rotating the front panel down (see Fig B(i) to B(iv), Pg. 3) for wrapper removing instructions.
- 2) Button is located in lower right corner of unit (See Fig. A, Pg. 4).

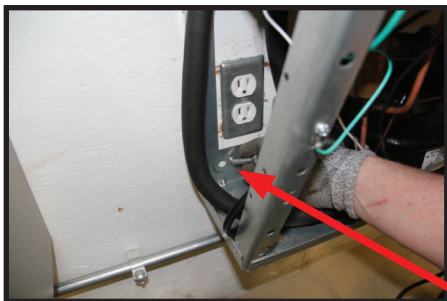

FIG. 2

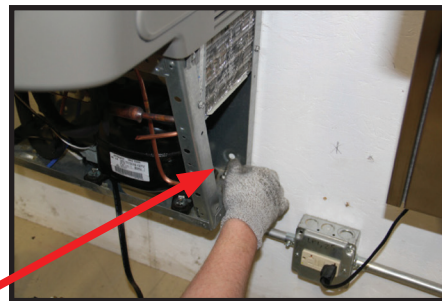

FIG. 3

Secure cooler frame to wall by installing (2) screws and washers (not supplied).

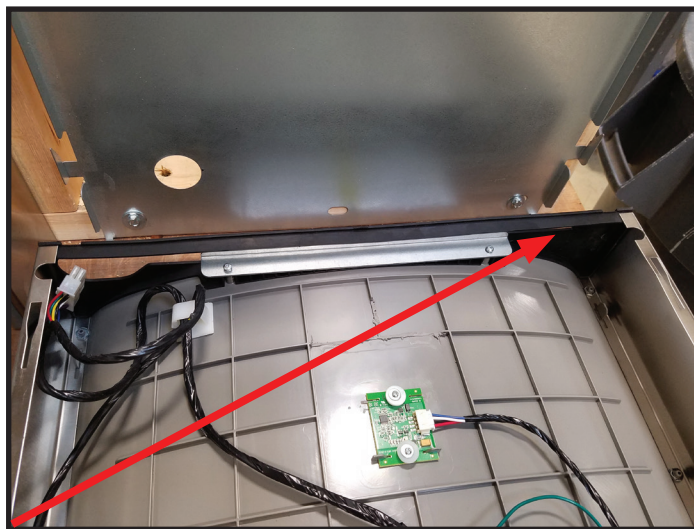

Fig. 4

Lay gasket along back of bottle filler mounting plate. Align BF and lay on cooler basin.

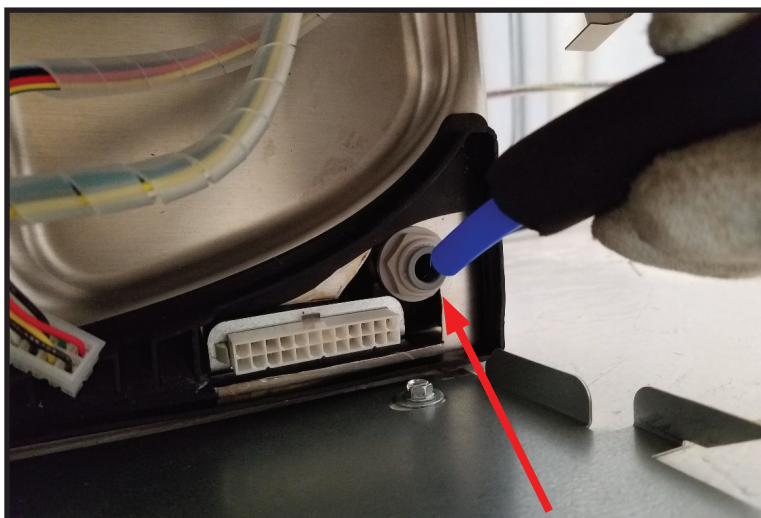

Fig. 5

Attach the 3/8 water line into the bulkhead fitting.
(Gasket removed from bottle filler for clarity)



Fig. 6

Connect the bottle filler electrical harness.
(Gasket removed from bottle filler for clarity)

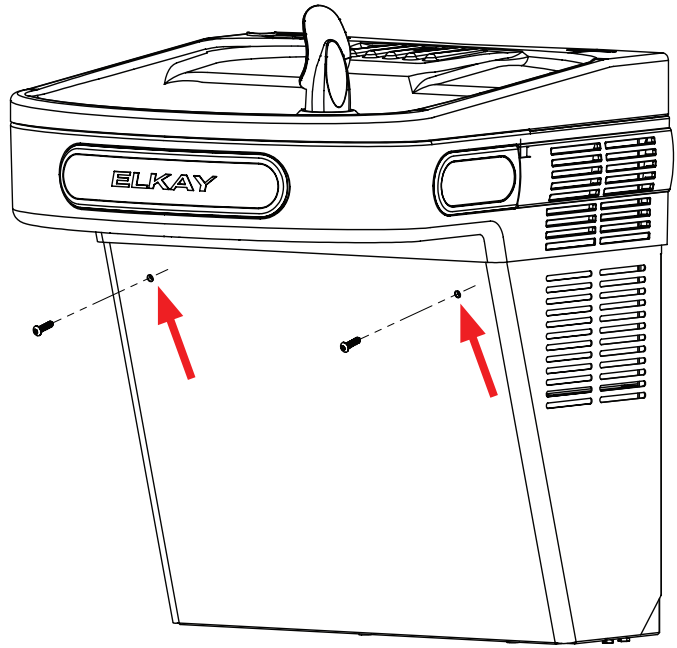

Fig. 7



Fig. 8a

plumbSMART
registration ID

MOUNTING BOLT HOLES (6)

WALL MOUNTING PLATE

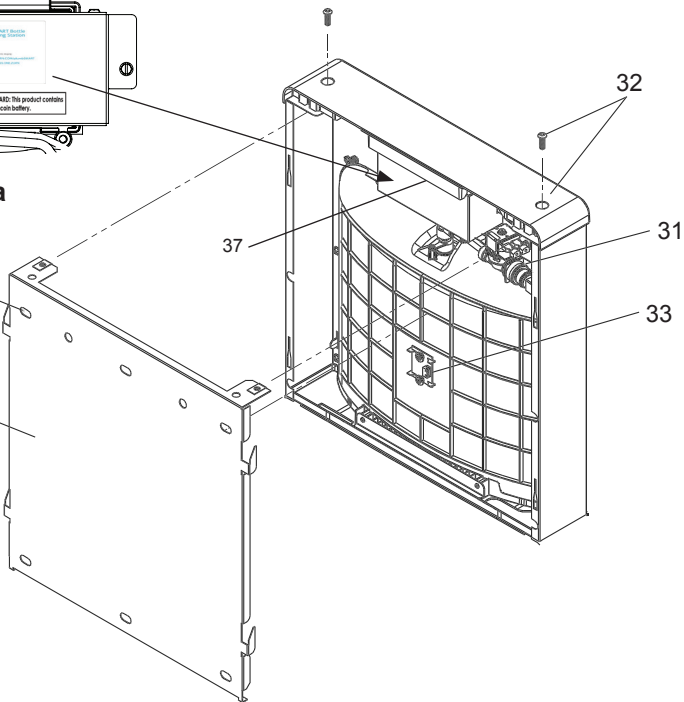

Fig. 8
BOTTLE FILLING UNIT

115V Refrigerated Wiring Diagram with Alpha/Numeric Display Connected-Ready - Enhanced Bottle Filler

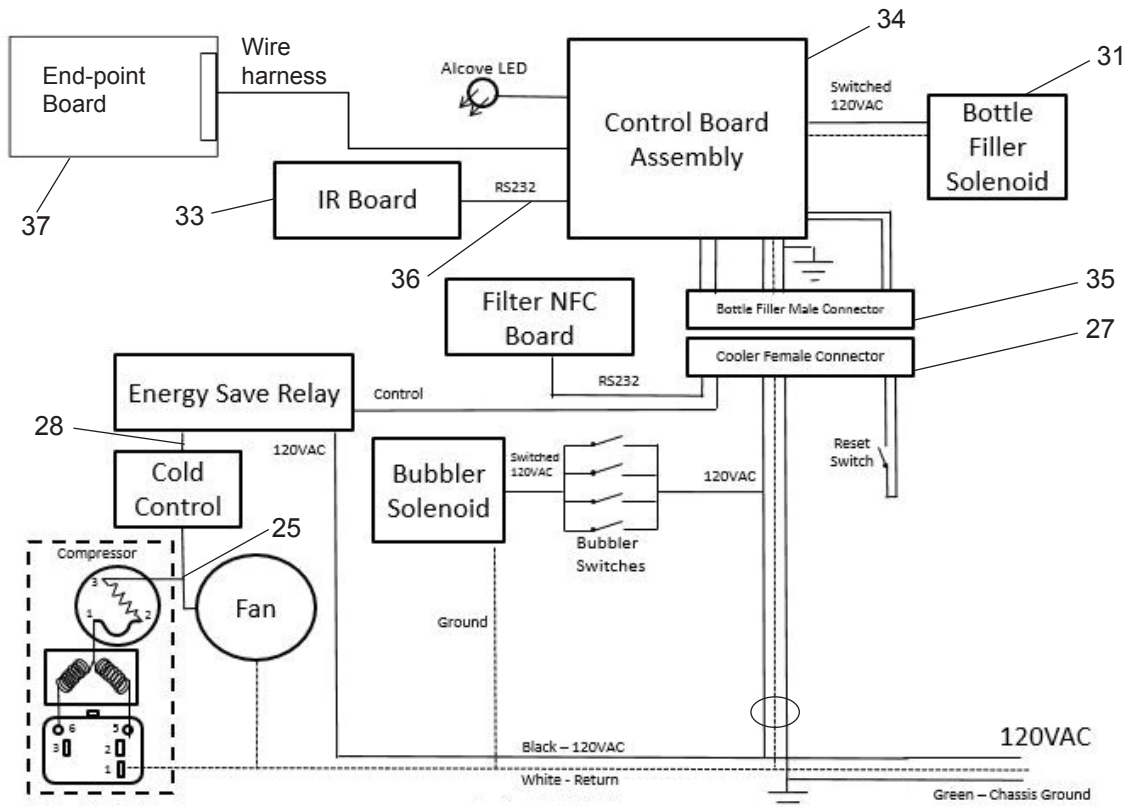

Fig. 9

⚠ **WARNING**

- INGESTION HAZARD:** This product contains a button cell or coin battery.
- DEATH** or serious injury can occur if ingested.
- A swallowed button cell or coin battery can cause **Internal Chemical Burns** in as little as **2 hours**.
- KEEP** new and used batteries **OUT OF REACH** of CHILDREN
- Seek immediate medical attention** if a battery is suspected to be swallowed or inserted inside any part of the body.

OPERATION OF QUICK CONNECT FITTINGS

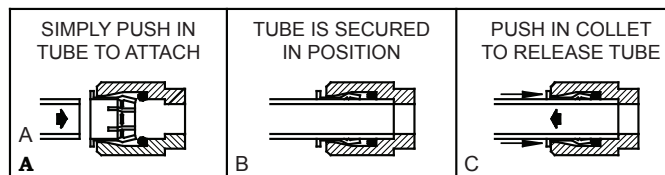
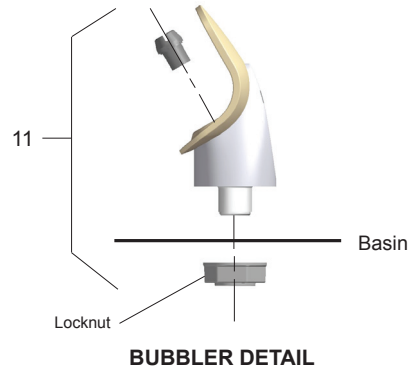

Fig. 10



Front of Filter Back of Filter

Fig. 11



BUBBLER DETAIL

Fig. 12

NOTE:
When installing replacement bubbler and pedestal, tighten nut only to hold parts snug in position. Do Not Overtighten.



Fig. 13

NOTE:
The filter status indicator shows the filter condition using colors. Blue indicates normal operation, no immediate attention needed. Red indicates immediate attention required to maintain proper function.



Scan for trouble shooting and to sign up for auto replenishment of authentic Elkay filters.

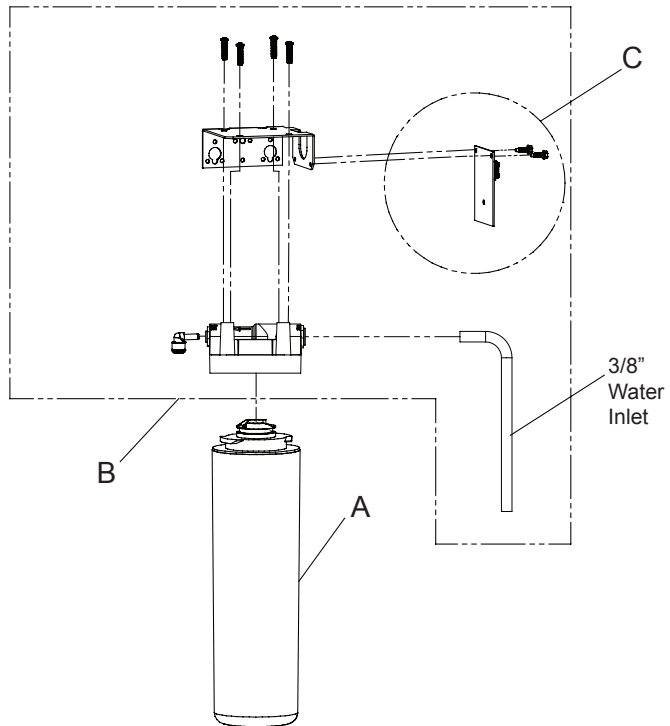

Fig. 14

WATERSENTRY® Filter Detail

WATERSENTRY® FILTER PARTS LIST		
ITEM NO.	PART NO.	DESCRIPTION
1	51300C	Filter 3000 Gal (standard)
2	51600C	Filter 6000 Gal (high capacity)
3	71300C	Filter 2250 Gal (PFOA/PFOS)
4	1000005214	Kit - Filter Head Fittings includes John Guest Fittings & 3/8" Elbow Filter Bracket/Screws
5	1000004409	Kit - NFC Board/Cover

Note: Danger! Electrical shock hazard. Disconnect power before servicing unit.

Service Instructions

Lower and Upper Shroud

To access the refrigeration system and plumbing connections, Remove two (2) screws from front of cooler to remove the lower shroud. To remove the upper shroud for access to the pushbars, regulator, solenoid valve or other components located in the top of the unit, remove lower shroud, disconnect drain, remove four screws from tabs along lower edge of upper shroud, unplug two wires and water tube.

Bubbler

To remove the bubbler, first disconnect the power supply. The underside of the bubbler can be reached through the access panel on the underside of the upper shroud. Remove the access panel by removing the retaining screw. To remove the bubbler, loosen locknut from the underside of the bubbler and remove the tubing from the quick connect fitting per the Operation Of Quick Connect Fittings section in the General Instructions. After servicing, replace the access panel and retaining screw.

Switches Behind the Push Bar

The regulator in an EZ cooler is always held fully open by the use of a single regulator nut (See Item 9, Fig. 15). Water is not dispensed until the pushbar is depressed to activate a switch which then opens a solenoid valve.

To remove sidebars, from the inside compress the flared tabs and pull out carefully. To reinstall side pushbars, the front of the pushbar is inserted first. While keeping the switch depressed, snap the rear of the pushbar into position.

Cleaning

Stainless Steel

- General cleaning: use an ordinary mild detergent and soft cloth, rinse and towel dry.
- Steel soap pads should never be used; particles can adhere to a stainless steel basin surface and will eventually rust.
- Light scratches are normal for stainless steel basins; over time they will blend into the uniform finish pattern.
- Do not use cleaners containing acids or chlorides, these will cause the stainless steel to oxidize.

Plastic Components

- General cleaning: use an ordinary mild detergent and soft cloth, rinse and towel dry.
- Wiping the surface clean to remove debris or build up will not hurt the antimicrobial properties.

Temperature Control

- Factory set at 50°F (+/- 5°F) under normal conditions. For altitude adjustments, refer to sticker on left side of top bar.

Stream Height Adjustment

VIEW OF UNDERSIDE OF BASIN SHROUD

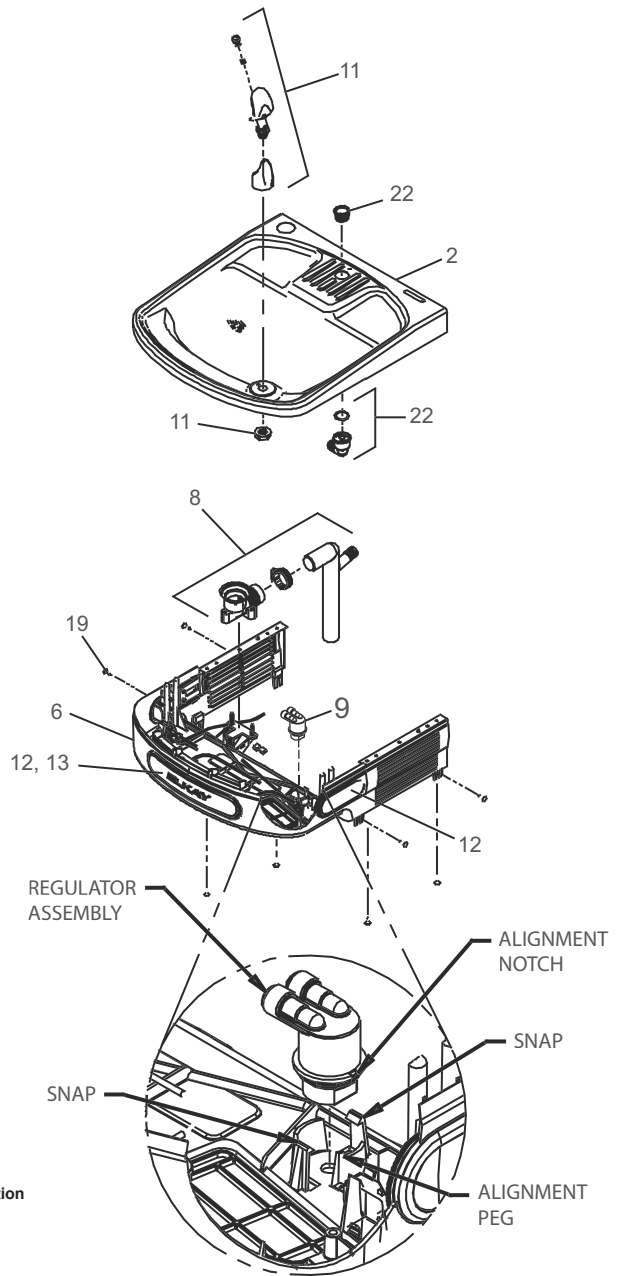
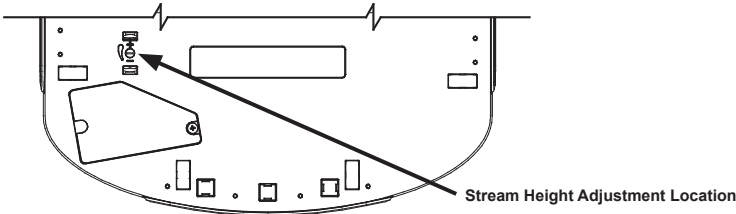

Fig. 15

Programming Instruction

Depress Button for 3 seconds to activate main menu - release									
Cycles thru main menu items 2 seconds each for 2 cycles then exits menu unless selected									
Cycles thru sub menu items 2 seconds each for 2 cycles then returns to main menu unless selected									
Selections are saved when the menu is exited									
Top level	Action	Sub Menu 1	Action	Sub Menu/action	Action	Sub Menu/action	Action	Sub Menu/action	End Action
Info	Momentary	Scrolls through all the settings on unit							Returns to Main Menu
Info	Momentary	Flashes error code							Returns to Main Menu
Set time	Momentary								Drops to next level when selected
		Day (Sunday-Saturday)	Momentary						Use push button to select the day on the display
		AM/PM	Momentary						Use push button to select AM or PM
		Hour (12 hour)	Momentary						Use push button to select Hour
		Min 6-69 in 5 minute increments	Momentary						Use push button to select closest minute
Filter	Momentary								Drops to next level when selected
		No	Momentary	Turn off filter status and errors					No Filter unit - Error codes related to filter status turned off
		Yes	Momentary	Default setting - Turn on filter status and errors					Filter status has default ON / Default has read write to filter, LED status display, filter error capability
Refig	Momentary								Drops to next level when selected
		No	Momentary	Disables E/S relay sets bottle fill time to 1.5gpm					Refrigeration off
		Yes	Momentary	Default setting - Enables E/S relay - sets time to 1.1gpm					Refrigeration on
Range	Momentary								Drops to next level when selected
		1-10	Momentary	Default setting 5 - Adjusts distance from sensor the bottle needs to be before turning before turning on or off the bottle filler					The lower the number, the closer to the sensor the bottle needs to be to activate
B-Light	Momentary								Returns to Main Menu
		25%	Momentary						Drops to next level when selected
		50%	Momentary						Returns to Main Menu
		75%	Momentary	Default Setting					Returns to Main Menu
		100%	Momentary						Returns to Main Menu
EnerSave	Momentary								Drops to next level when selected
		Off	Momentary	Default Setting					Returns to Main Menu
		On	Momentary	Set Energy Save Schedule					Drops to next level when selected
							Select Weekday		Drops to next level when selected
								Momentary	Select time on
								Momentary	Select time off
									Drops to next level when selected
									Drops to next level when selected
								Momentary	Select time on
								Momentary	Select time off
									Drops to next level when selected
									Returns to Main Menu

Enhanced EZH2O Error Codes

Error Code	Error Description	Corrective Action
	Bottle filler area obstructed	<ul style="list-style-type: none"> • Remove obstruction. • Clean lens on IR sensor • Unplug unit for at least 30 seconds and restart • If error repeats, replace IR sensor
E013	Missing or Incompatible Filter	<ul style="list-style-type: none"> • Check that filter is installed correctly (label facing forward, white tag facing back) • Unplug unit for at least 30 seconds and restart • Replace filter • Replace filter head assembly with repair kit • If error repeats, contact certified service professional
E013 & E014	Missing NFC Board	<ul style="list-style-type: none"> • Unplug unit for at least 30 seconds and restart • Verify cable connector is plugged into NFC board on filter head assembly • Replace filter head assembly with repair kit • If error repeats, contact certified service professional

Pictured is unit only without bottle filler.

Note: Danger! Electrical shock hazard. Disconnect power before servicing unit.

Uses HFC-134A refrigerant

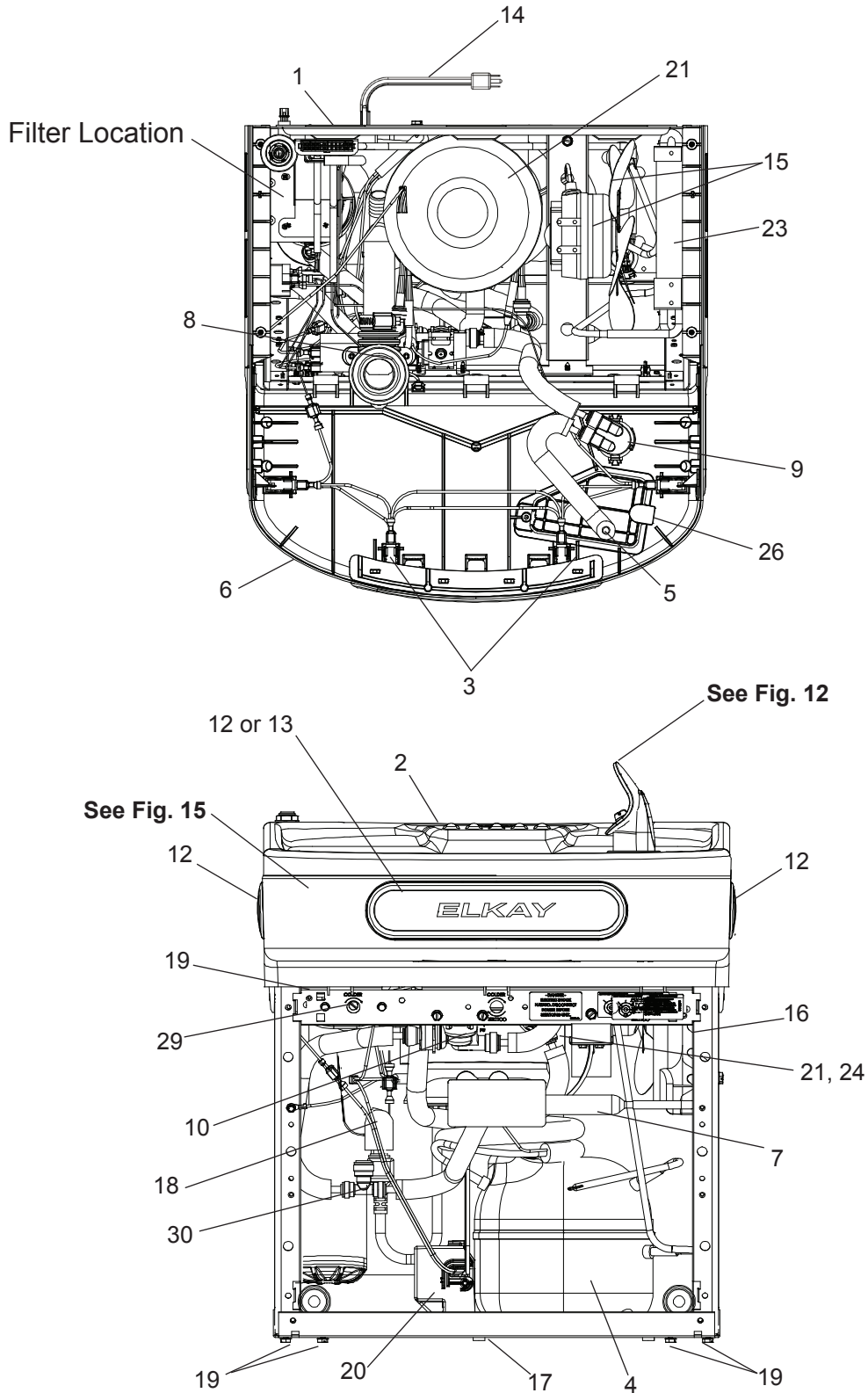

Fig. 16

115V PARTS LIST FOR LZS8WSAP-W1		
ITEM NO.	PART NO.	DESCRIPTION
1	28401C	Hanger Bracket
2	0000001337	Basin - Stainless Steel
3	36216C	Wiring - Front/Side Push Bar
*4	36322C	Compr - Service Pak 115V EMIS70HHR
5	56092C	Tube - Poly (72")
6	2000001564	Assy - Arctic White Shroud - Upper (Front Side Push)
7	66703C	Drier
8	1000001877	Kit - Drain Replacement (Bottle Filler) (Bracket, Tube, Fitting, Clamp)
9	1000004564	Kit - Regular/Holder/Nut
10	1000004572	Kit - Solenoid Valve/Regulator Assembly
11	2000002087	Kit - Flexi Bubbler/"O"-Ring/Nut (Arctic White)
12	2000002077	Kit - Pushbar (Front/Side) TL (Arctic White)
13	2000002079	Kit - Pushbar (Front Only) (Arctic White)
14	1000004568	Power Cord
15	98775C	Kit - Fan Motor/Blade/Screws/Nut
16	98776C	Kit - Condenser/Drier/Wire Ties
17	98777C	Kit - Compr Mtg Hdwe/Grommets/Clips/Studs
18	98778C	Kit - Heatx/Drier
19	98898C	Kit - Hardware
20	0000000238	Kit - 115V Electricals (Relay, Overload, Cover)
21	98724C	Kit - Evap. Replacement
22	1000001812	Kit - Bottle Filler Drain
23	56237C	Shroud
24	1000001602	Kit - 75583C Elbow 5/16" x 1/4" (3 Pack)
25	1000004559	Wire Assy - Jumper
26	56213C	Access Panel
27	1000004547	Harness - Cooler
28	1000004550	Wire - 6" Jumper
29	98773C	Kit - Cold Control
NS	1100000029	Drop Down Wrapper Replacement Kit (Arctic White)

115V PARTS LIST FOR LZS8WSMP-W1		
ITEM NO.	PART NO.	DESCRIPTION
1	28401C	Hanger Bracket
2	0000001337	Basin - Stainless Steel
3	36216C	Wiring - Front/Side Push Bar
*4	36322C	Compr - Service Pak 115V EMIS70HHR
5	56092C	Tube - Poly (72")
6	2000001859	Assy - Midnight Black Shroud - Upper (Front Side Push)
7	66703C	Drier
8	1000001877	Kit - Drain Replacement (Bottle Filler) (Bracket, Tube, Fitting, Clamp)
9	1000004564	Kit - Regular/Holder/Nut
10	1000004572	Kit - Solenoid Valve/Regulator Assembly
11	2000002086	Kit - Flexi Bubbler/"O"-Ring/Nut (Midnight Black)
12	2000002076	Kit - Pushbar (Front/Side) TL (Midnight Black)
13	2000002078	Kit - Pushbar (Front Only) (Midnight Black)
14	1000004568	Power Cord
15	98775C	Kit - Fan Motor/Blade/Screws/Nut
16	98776C	Kit - Condenser/Drier/Wire Ties
17	98777C	Kit - Compr Mtg Hdwe/Grommets/Clips/Studs
18	98778C	Kit - Heatx/Drier
19	98898C	Kit - Hardware
20	0000000238	Kit - 115V Electricals (Relay, Overload, Cover)
21	98724C	Kit - Evap. Replacement
22	1000001812	Kit - Bottle Filler Drain
23	56237C	Shroud
24	1000001602	Kit - 75583C Elbow 5/16" x 1/4" (3 Pack)
25	1000004559	Wire Assy - Jumper
26	56213C	Access Panel
27	1000004547	Harness - Cooler
28	1000004550	Wire - 6" Jumper
29	98773C	Kit - Cold Control
NS	1100000028	Drop Down Wrapper Replacement Kit (Midnight Black)

NS = Not Shown

NS = Not Shown

BOTTLE FILLER REPLACEMENT PART KITS FOR LZS8WSAP-W1		
ITEM NO.	PART NO.	DESCRIPTION
NS	98546C	Kit - Aerator Replacement
30	98549C	Kit - Hardware & Waterway (BF)
31	1000004573	Kit - Solenoid 120V (BF)
NS	2000002090	Nameplate - Elkay Filtered (AW)
32	2000002072	Kit - Top Cover Assy (BF) (AW)
33	1000005219	Kit - IR Sensor K+
34	2000001906	Kit - Connected Ready LED Board (BBB/R)
NS	1000004436	Kit - Tower/Basin Gasket
35	1000004546	Harness - Bottle Filler
36	1000004549	Harness - LED/IR Board
37	PLZSRK-W1	Endpoint Board Service Kit

BOTTLE FILLER REPLACEMENT PART KITS FOR LZS8WSMP-W1		
ITEM NO.	PART NO.	DESCRIPTION
NS	98546C	Kit - Aerator Replacement
30	98549C	Kit - Hardware & Waterway (BF)
31	1000004573	Kit - Solenoid 120V (BF)
NS	2000002089	Nameplate - Elkay Filtered (MB)
32	2000002071	Kit - Top Cover Assy (BF) (MB)
33	1000005219	Kit - IR Sensor K+
34	2000001906	Kit - Connected Ready LED Board (BBB/R)
NS	1000004436	Kit - Tower/Basin Gasket
35	1000004546	Harness - Bottle Filler
36	1000004549	Harness - LED/IR Board
37	PLZSRK-W1	Endpoint Board Service Kit

NS = Not Shown

NS = Not Shown

115V PARTS LIST FOR LZS8WSSP-W1		
ITEM NO.	PART NO.	DESCRIPTION
1	28401C	Hanger Bracket
2	0000001337	Basin - Stainless Steel
3	36216C	Wiring - Front/Side Push Bar
*4	36322C	Compr - Service Pak 115V EMIS70HHR
5	56092C	Tube - Poly (72")
6	56229C	Assy - Shroud - Upper (Front Side Push) (Standard Gray)
7	66703C	Drier
8	1000001877	Kit - Drain Replacement (Bottle Filler) (Bracket, Tube, Fitting, Clamp)
9	1000004564	Kit - Regular/Holder/Nut
10	1000004572	Kit - Solenoid Valve/Regulator Assembly
11	56073C	Kit - Flexi Bubbler/"O"-Ring/Nut (Standard Gray)
12	98734C	Kit - Pushbar (Front/Side) EZS TL (Standard Gray)
13	1000001600	Kit - Pushbar (Front Only) (Standard Gray)
14	1000004568	Power Cord
15	98775C	Kit - Fan Motor/Blade/Screws/Nut
16	98776C	Kit - Condenser/Drier/Wire Ties
17	98777C	Kit - Compr Mtg Hdwe/Grommets/Clips/Studs
18	98778C	Kit - Heatx/Drier
19	98898C	Kit - Hardware
20	0000000238	Kit - 115V Electricals (Relay, Overload, Cover)
21	98724C	Kit - Evap. Replacement
22	1000001812	Kit - Bottle Filler Drain
23	56237C	Shroud
24	1000001602	Kit - 75583C Elbow 5/16" x 1/4" (3 Pack)
25	1000004559	Wire Assy - Jumper
26	56213C	Access Panel
27	1000004547	Harness - Cooler
28	1000004550	Wire - 6" Jumper
29	98773C	Kit - Cold Control
NS	1100000018	Drop Down Wrapper Replacement Kit - Stainless Steel

ATTENTION:
 If the product serial number is before 190424189, please refer to archived documents section of Elkay.com for the most accurate parts list. (www.elkay.com/archived-documents)

NS = Not Shown

***INCLUDES RELAY & OVERLOAD. IF UNDER WARRANTY, REPLACE WITH SAME COMPRESSOR USED IN ORIGINAL ASSEMBLY.**
NOTE: All correspondence pertaining to any of the above water coolers or orders for repair parts MUST include Model No. and Serial No. of cooler, name and part number of replacement part.

**BOTTLE FILLER
 REPLACEMENT PART KITS
 FOR LZS8WSSP-W1**

ITEM NO.	PART NO.	DESCRIPTION
NS	98546C	Kit - Aerator Replacement
30	98549C	Kit - Hardware & Waterway (BF)
31	1000004573	Kit - Solenoid 120V (BF)
NS	1000002088	Nameplate - Elkay Filtered (SG)
32	1000002433	Kit - Top Cover Assy (BF) (SG)
33	1000005219	Kit - IR Sensor K+
34	2000001906	Kit - Connected Ready LED Board (BBB/R)
NS	1000004436	Kit - Tower/Basin Gasket
35	1000004546	Harness - Bottle Filler
36	1000004549	Harness - LED/IR Board
37	PLZSRK-W1	Endpoint Board Service Kit (BBB/R)

NS = Not Shown

FCC COMPLIANCE STATEMENT

CAUTION: Changes or modifications not expressly approved could void your authority to use this equipment

This device complies with Part 15 of the FCC Rules. Operation to the following two conditions: (1) This device may not cause harmful interference, and (2) this device must accept any interference received, including interference that may cause undesired operation

Note: This equipment has been tested and found to comply with the limits for a Class B digital device, pursuant to part 15 of the FCC Rules. These limits are designed to provide reasonable protection against harmful interference in a residential installation. This equipment generates, uses and can radiate radio frequency energy and, if not installed and used in accordance with the instructions, may cause harmful interference to radio communications. However, there is no guarantee that interference will not occur in a particular installation. If this equipment does cause harmful interference to radio or television reception, which can be determined by turning the equipment off and on, the user is encouraged to try to correct the interference by one or more of the following measures:

- Reorient or relocate the receiving antenna.
- Increase the separation between the equipment and receiver.
- Connect the equipment into an outlet on a circuit different from that to which the receiver is connected.
- Consult the dealer or an experienced radio/TV technician for help.

The device shall be used in such a manner that the potential for human contact normal operation is minimized. This equipment complies with FCC radiation exposure limits set forth for an uncontrolled environment. This equipment should be installed and operated with a minimum distance of 20cm between the radiator and your body. This device and its antenna(s) must not be co-located or operating in conjunction with any other antenna or transmitter.

INDUSTRY CANADA STATEMENT

This device complies with Industry Canada license-exempt RSS standard(s). Operation is subject to the following two conditions: (1) this device may not cause interference, and (2) this device must accept any interference, including interference that may cause undesired operation of the device.

Le présent appareil est conforme aux CNR d'Industrie Canada applicables aux appareils radio exempts de licence. L'exploitation est autorisée aux deux conditions suivantes : (1) l'appareil ne doit pas produire de brouillage, et (2) l'utilisateur de l'appareil doit accepter tout brouillage radioélectrique subi, même si le brouillage est susceptible d'en compromettre le fonctionnement.

The device shall be used in such a manner that the potential for human contact normal operation is minimized. This equipment complies with RSS-102 radiation exposure limits. This equipment should be installed and operated with a minimum distance of 20 cm between the radiator and your body. This device and its antenna(s) must not be co-located or operating in conjunction with any other antenna or transmitter.

Le dispositif doit être utilisé de manière à minimiser le potentiel de fonctionnement normal par contact humain. Cet équipement est conforme aux limites d'exposition au rayonnement RSS-102. Cet équipement doit être installé et utilisé avec une distance minimale de 20 cm entre le radiateur et votre corps. Cet appareil et son (ses) antenne (s) ne doivent pas être co-localisés ou utilisés conjointement avec une autre antenne ou un autre émetteur.



FOR PARTS, CONTACT YOUR LOCAL DISTRIBUTOR OR CALL 1.800.834.4816
REPAIR SERVICE INFORMATION TOLL FREE NUMBER 1.800.260.6640

PRINTED IN U.S.A.

ELKAY MANUFACTURING COMPANY • 1333 BUTTERFIELD ROAD • DOWNERS GROVE, IL 60515 • 630.574.8484 • www.elkay.com