

# **ELKAY®**

## **Enhanced**

### **INSTALLATION & USE MANUAL**

#### **LZ™ Series Bottle Filling Stations & Coolers**



\*Versatile cooler design allows units to be installed either left-hand high and right-hand low or left-low and right high. Basin change may be required. See desired rough-in to help determine if the basin change is necessary.

**Important:** The refrigerated coolers must be hung on the right side.

**Patent** [zurn-elkay.com/patents](http://zurn-elkay.com/patents)

⚠ **WARNING:** Cancer and Reproductive Harm - [www.P65Warnings.ca.gov](http://www.P65Warnings.ca.gov)

⚠ **ADVERTENCIA:** Cáncer y daño reproductivo - [www.P65Warnings.ca.gov](http://www.P65Warnings.ca.gov)

⚠ **AVERTISSEMENT:** Cancer et effets néfastes sur la reproduction - [www.P65Warnings.ca.gov](http://www.P65Warnings.ca.gov)

**STANDARD ROUGH-IN FOR LEFT-HAND HIGH, BOTTLE FILLER LOW MODELS**  
 BOSQUEJO ESTÁNDAR PARA MODELOS CON LA LLENADORA DE BOTELLAS BAJA Y LA PARTE IZQUIERDA ALTA  
 DISPOSITION DE CANALISATIONS STANDARD, POUR INSTALLATION GAUCHE HAUTE ET REMPLISSEUSE DE BOUTEILLE BASSE

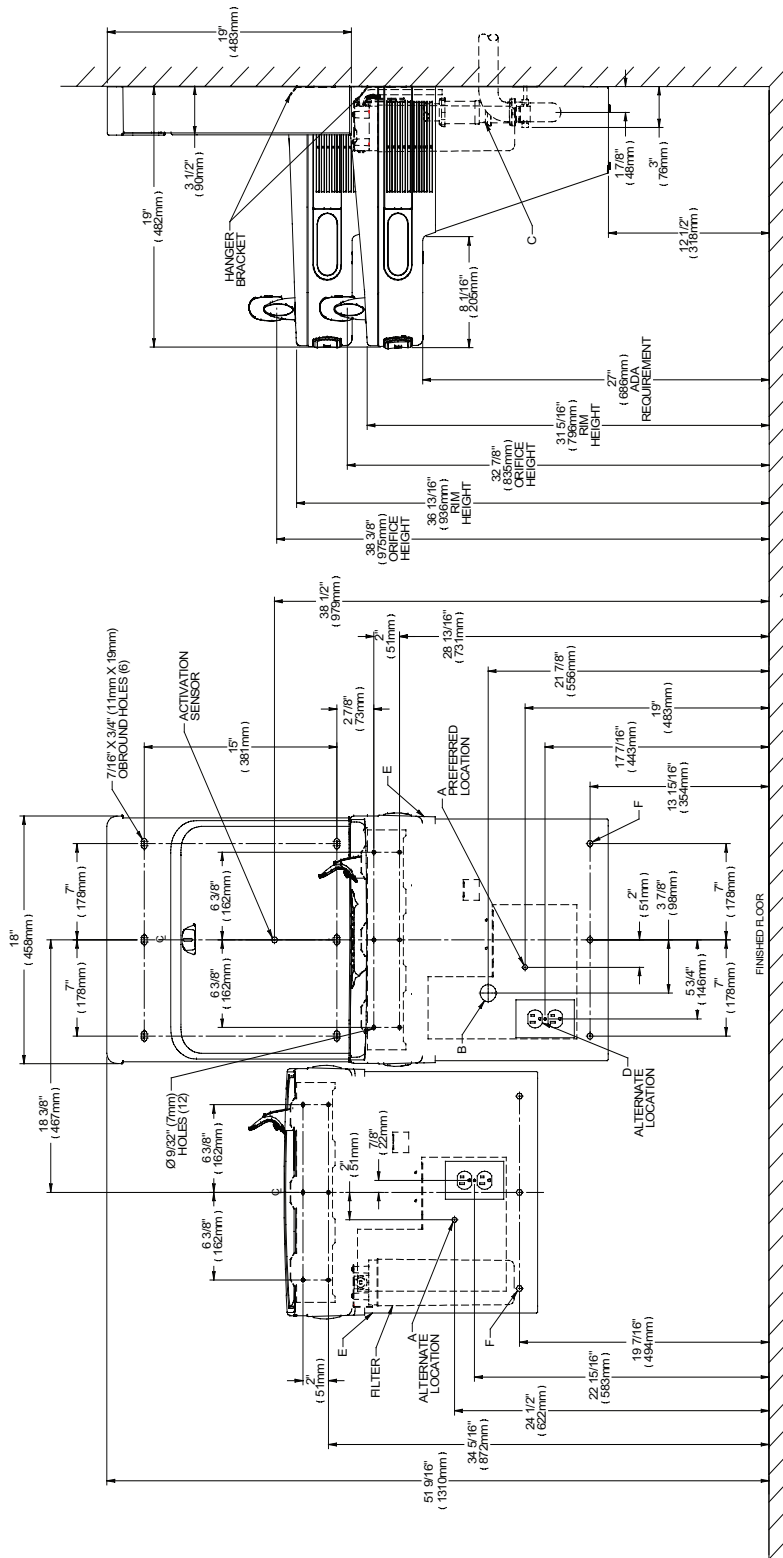

**FIG. 1**

**REDUCE HEIGHT BY 3 INCHES FOR INSTALLATION OF CHILDREN'S ADA COOLER**  
 REDUZCA LA ALTURA EN 76 mm (3") PARA LA INSTALACIÓN DEL BEBEDERO CON CLASIFICACIÓN ADA PARA NIÑOS  
 RÉDUISSE LA HAUTEUR DE 76 mm (3") POUR LES INSTALLATIONS À LA NORME ADA ENFANTS

- LEGEND/LEYENDA/LÉGENDE**
- A =** RECOMMENDED WATER SUPPLY LOCATION 3/8 O.D. UNPLATED COPPER TUBE CONNECT STUB WITH SHUT OFF (BY OTHERS) 3 IN. (76mm)  
 UBICACIÓN RECOMENDADA DEL SUMINISTRO DE AGUA. TUBERÍA DE COBRE SIN REVESTIMIENTO DE 3/8" DE DIÁM. EXT. ADAPTADOR DE CONEXIÓN CON VÁLVULA DE CIERRE (DE TERCEROS) MÁXIMO A 76 mm (3") DE LA PARED.  
 EMPLACEMENT RECOMMANDÉ DE L'ARRIVÉE D'EAU. TUBE EN CUIVRE NON PLAQUÉ DE 3/8 PO DE DIA. EXT. RACCORDER À LA CONDUITE D'ALIMENTATION AVEC UN ROBINET D'ARRÊT (NON FOURNI) À 76 mm (3 PO) MAXIMUM DU MUR.  
 PRESSIÓN MÁXIMA DE SUMINISTRO DE AGUA: 105 PSI (0.73 MPa)
  - B =** RECOMMENDED LOCATION FOR WASTE OUTLET 1-1/2" O.D. DRAIN STUB 2 IN. OUT FROM WALL  
 UBICACIÓN RECOMENDADA DE LA SALIDA DE DESECHOS. ADAPTADOR DE DESAGUE DE 1-1/2" DE DIÁM. EXT. A 51 mm (2") DE LA PARED.  
 EMPLACEMENT RECOMMANDÉ DE LA SORTIE D'ÉVACUATION DE 1-1/2 PO DE DIA. EXT. DÉPASSANT DE 51 mm (2 PO) HORS DU MUR  
 NO SE INCLUDE SIFÓN DE 1-1/2" (2 PO) NON FOURNI
  - C =** 1-1/2" TRAP NOT FURNISHED  
 SIFÓN DE 1-1/2 PO NON FOURNI
  - D =** ELECTRICAL SUPPLY (3) WIRE RECESSED BOX DUPLEX OUTLET\*\*  
 SUMINISTRO ELÉCTRICO (3) CAJA ENCHUFE DE ALAMBRE SALIDA DÚPLEX  
 ALIMENTATION ÉLECTRIQUE (3) BÔTIER ENCASTRE  
 PARA GARANTIR LA VENTILACIÓN ADECUADA, MANTENGA 152 mm (6") (MIN.) DE SEPARACIÓN DESDE LAS REJILLAS DEL GABINETE HASTA LA PARED.  
 POUR ASSURER UNE AÉRATION SUFFISANTE, PRÉVOIR UN DÉGAGEMENT DE 152 mm (6 PO) (MIN.) ENTRE LES ÉVÉNENTS DE L'ENCEINTE ET LE MUR.
  - E =** INSURE PROPER VENTILATION BY MAINTAINING 6" (152 mm) (MIN.) CLEARANCE FROM CABINET LOUVERS TO WALL.  
 \*\*NEW INSTALLATIONS MUST USE GROUND FAULT CIRCUIT INTERRUPTER (GFCI)  
 \*\*Las nuevas instalaciones deben usar un interruptor de circuito de falla a tierra (GFCI, por sus siglas en inglés)  
 NOTE: It is highly recommended that the circuit be dedicated and the load protection be sized for 20 amps.  
 NOTE: Es muy recomendable que el circuito esté dedicado y que la protección de carga tenga un tamaño de 20 amperios.
  - F =** 7/16 BOLT HOLES FOR FASTENING UNIT TO WALL  
 ORIFICIOS PARA PERNOS DE 7/16. PARA FIJAR LA UNIDAD A LA PARED  
 TROUS DE VIS DE 7/16 PO POUR LA FIXATION DE L'APPAREIL AU MUR  
 \*\*NEW INSTALLATIONS MUST USE GROUND FAULT CIRCUIT INTERRUPTER (GFCI)  
 \*\*Las nuevas instalaciones deben usar un interruptor de circuito de falla a tierra (GFCI, por sus siglas en inglés)
- REMARKS:** Il est fortement recommandé de dédier le circuit et de dimensionner la protection de charge à 20 ampères.

**ALTERNATE ROUGH-IN FOR RIGHT-HAND HIGH, BOTTLE FILLER LOW MODELS – REQUIRES BASIN ASSY CHANGE**

BOSQUEJO ALTERNATIVO PARA MODELOS CON LA LLENADORA DE BOTELLAS BAJA Y LA PARTE DERECHA ALTA: REQUIERE CAMBIAR EL CONJUNTO DE TARJA  
 AUTRE DISPOSITION DE CANALISATIONS, POUR INSTALLATION DROITE HAUTE ET REMPLISSEUSE DE BOUTEILLE BASSE – MODIFICATION DE LA FONTAINE REQUISE

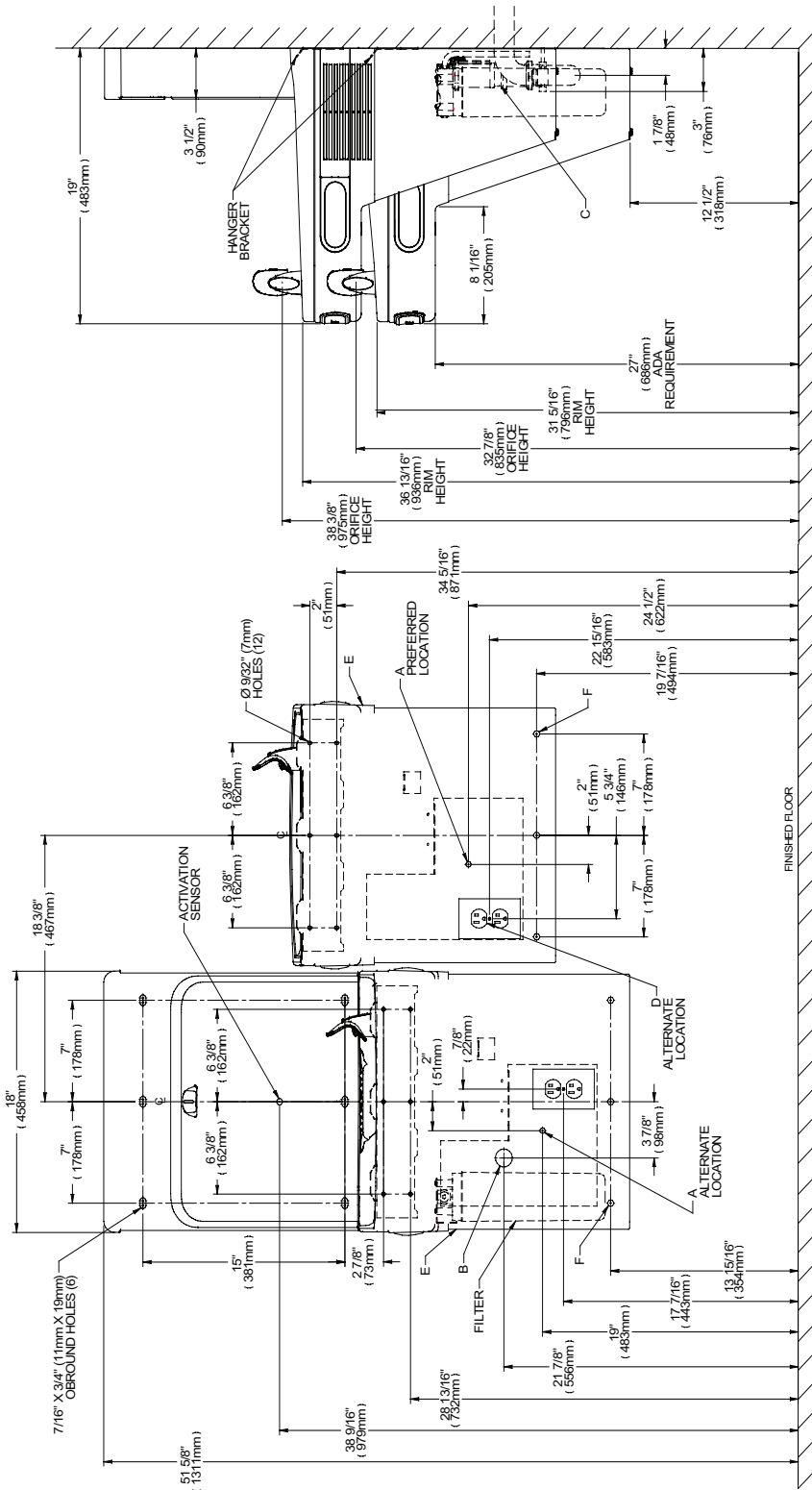

**FIG. 2**

**REDUCE HEIGHT BY 3 INCHES FOR INSTALLATION OF CHILDREN'S ADA COOLER**  
 REDUZCA LA ALTURA EN 76 mm (3") PARA LA INSTALACIÓN DEL BEBEDERO CON CLASIFICACIÓN ADA PARA NIÑOS  
 RÉDUCEZ LA HAUTEUR DE 76 mm (3 PO) POUR LES INSTALLATIONS À LA NORME ADA ENFANTS

**NOTE: TO COMPLETE THIS OPTION, THE VERSATILE BF BASIN KIT (VERSATILEBFKIT) MUST BE ORDERED SEPARATELY.**  
 NOTA: PARA COMPLETAR ESTA OPCIÓN, SE DEBE PEDIR POR SEPARADO EL KIT DE LAVABO VERSÁTIL BF (VERSATILEBFKIT).  
 REMARQUE : POUR COMPLETER CETTE OPTION, LE KIT DE LAVABO POLYVALENT BF (VERSATILEBFKIT) DOIT ÊTRE COMMANDE SEPARÉMENT.

- LEGEND/LEYENDA/LEGÈNDE**
- A =** RECOMMENDED WATER SUPPLY LOCATION 3/8 O.D. UNPLATED COPPER TUBE CONNECT STUB WITH SHUT OFF (BY OTHERS) 3 IN. (76mm)  
 MAXIMUM OUT FROM WALL, MAXIMUM WATER SUPPLY PRESSURE: 105 PSI (0.73 MPa)  
 UBICACIÓN RECOMENDADA DEL SUMINISTRO DE AGUA, TUBERÍA DE COBRE SIN REVESTIMIENTO DE 3/8" DE DIAM. EXT. ADAPTADOR DE CONEXIÓN CON VALVULA DE CIERRE (DE TERCEROS) MÁXIMO A 76 mm (3") DE LA PARED.  
 PRESIÓN MÁXIMA DE SUMINISTRO DE AGUA: 105 PSI (0.73 MPa)  
 EMPLACEMENT RECOMMANDÉ DE L'ARRIVÉE D'EAU, TUBE EN CUIVRE NON PLÂQUÉ DE 3/8 PO DE DIA. EXT. RACCORDER À LA CONDUITE D'ALIMENTATION AVEC UN ROBINET D'ARRÊT (NON FOURNI) A 76 mm (3 PO) MAXIMUM DU MUR
  - B =** RECOMMENDED LOCATION FOR WASTE OUTLET 1-1/2" O.D. DRAIN STUB 2 IN. OUT FROM WALL  
 UBICACIÓN RECOMENDADA DE LA SALIDA DE DESCHOS, ADAPTADOR DE DESAGUE DE 1-1/2" DE DIAM. EXT.: A 51 mm (2") DE LA PARED.  
 EMPLACEMENT RECOMMANDÉ DE LA SORTIE D'ÉCOULEMENT, CONDUITE D'ÉVACUATION DE 1-1/2 PO DE DIA. EXT. DÉPASSANT DE 51 mm (2 PO) HORS DU MUR
  - C =** 1-1/2" TRAP NOT FURNISHED  
 NO SE INCLUDE SIFÓN DE 1-1/2"  
 SIPHON DE 1-1/2 PO NON FOURNI
  - D =** ELECTRICAL SUPPLY (3) WIRE RECESSED BOX DUPLEX OUTLET\*\*  
 SUMINISTRO ELÉCTRICO (3) CAJA ENCHUFE DE ALAMBRE SALIDA DUPLEX  
 ALIMENTATION ÉLECTRIQUE (3) BOUTIER ENCASTRÉ
  - E =** INSURE PROPER VENTILATION BY MAINTAINING 6" (152 mm) (MIN.) CLEARANCE FROM CABINET LOUVERS TO WALL.  
 PARA GARANTIZAR LA VENTILACIÓN ADECUADA, MANTENGA 152 mm (6") (MIN.) DE SEPARACIÓN DESDE LAS REJILLAS DEL GABINETE HASTA LA PARED.  
 POUR ASSURER UNE AÉRATION SUFFISANTE, PRÉVOIR UN DÉGAGEMENT DE 152 mm (6 PO) (MIN.) ENTRE LES ÉVÉNENTS DE L'ENCEINTE ET LE MUR.
  - F =** 7/16 BOLT HOLES FOR FASTENING UNIT TO WALL  
 ORIFICIOS PARA PERNOS DE 7/16. PARA FIJAR LA UNIDAD A LA PARED  
 TROUS DE VIS DE 7/16 PO POUR LA FIXATION DE L'APPAREIL AU MUR
- \*\*NEW INSTALLATIONS MUST USE GROUND FAULT INTERRUPTER (GFCI)**  
**\*\*Las nuevas instalaciones deben usar un interruptor de circuito de falla a tierra (GFCI, por sus siglas en inglés)**  
**\*\*It is highly recommended that the circuit be dedicated and the load protection be sized for 20 amps.**  
**NOTE: Es muy recomendable que el circuito esté dedicado y que la protección de carga tenga un tamaño de 20 amperios.**  
**REMARQUE: Il est fortement recommandé de dédier le circuit et de dimensionner la protection de charge à 20 ampères.**

**ALTERNATE ROUGH-IN FOR LEFT-HAND LOW, BOTTLE FILLER HIGH MODELS**  
 BOSQUEJO ALTERNATIVO PARA MODELOS CON LA LLENADORA DE BOTELLAS ALTA Y LA PARTE IZQUIERDA BAJA  
 AUTRE DISPOSITION DE CANALISATIONS, POUR INSTALLATION GAUCHE BASSE ET REMPLISSEUSE DE BOUTEILLE HAUTE

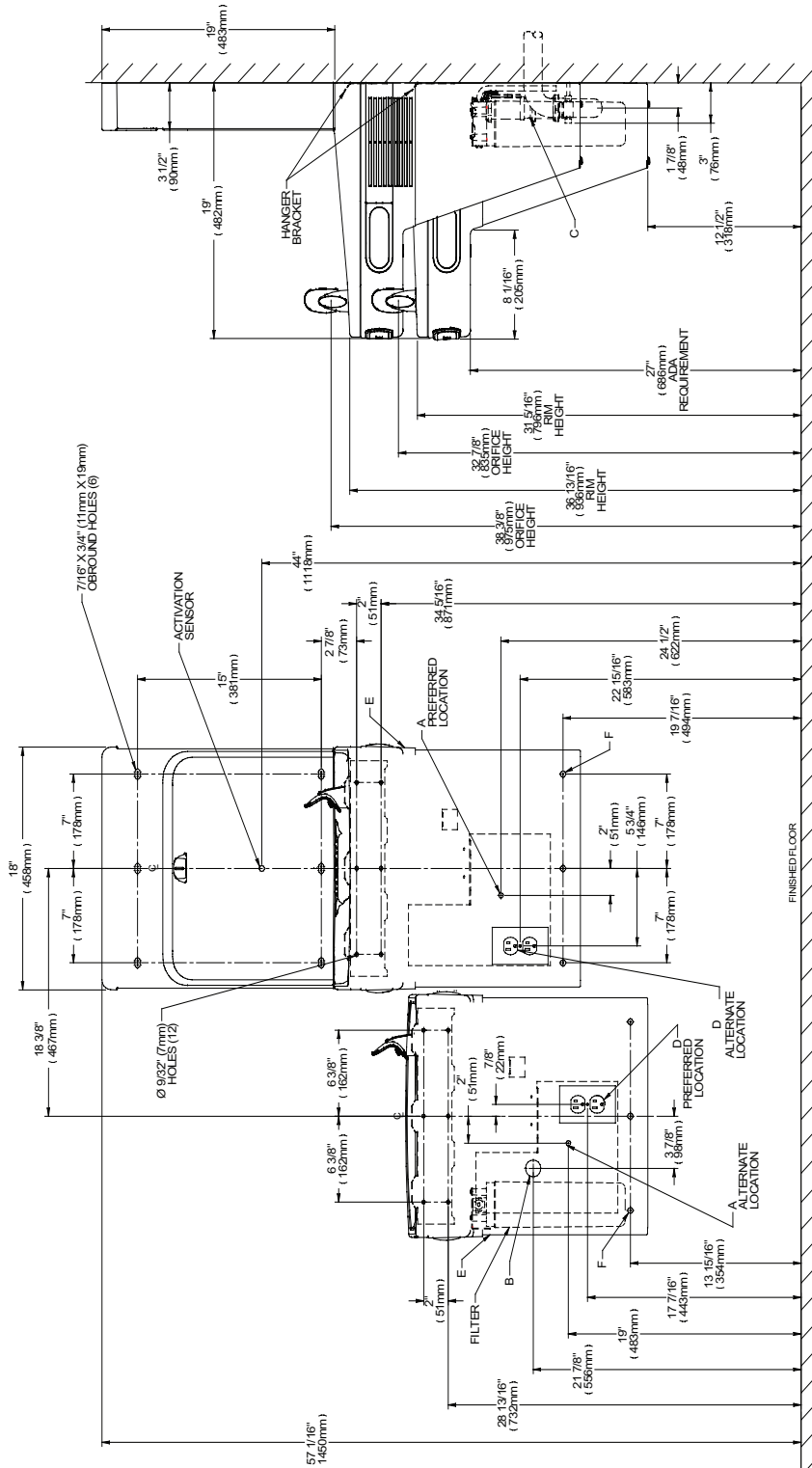

**FIG. 3**

**REDUCE HEIGHT BY 3 INCHES FOR INSTALLATION OF CHILDREN'S ADA COOLER**  
 REDUZCA LA ALTURA EN 76 mm (3") PARA LA INSTALACION DEL BEBEDERO CON CLASIFICACION ADA PARA NIÑOS  
 REDUIRE LA HAUTEUR DE 76 mm (3 PO) POUR LES INSTALLATIONS À LA NORME ADA ENFANTS

- LEGEND/LEYENDA/LÉGENDE**
- A =** RECOMMENDED WATER SUPPLY LOCATION 3/8 O.D. UNPLATED COPPER TUBE CONNECT STUB WITH SHUT OFF (BY OTHERS) 3 IN. (76mm)  
 MAXIMUM OUT FROM WALL, MAXIMUM WATER SUPPLY PRESSURE: 105 PSI (0.73 MPa)  
 UBICACION RECOMENDADA DEL SUMINISTRO DE AGUA, TUBERIA DE COBRE SIN REVESTIMIENTO DE 3/8" DE DIAM. EXT. ADAPTADOR DE CONEXION CON VALVULA DE CIERRE (DE TERCEROS) MÁXIMO A 76 mm (3") DE LA PARED.  
 PRESION MÁXIMA DE SUMINISTRO DE AGUA: 105 PSI (0.73 MPa)
  - B =** RECOMMENDED LOCATION FOR WASTE OUTLET 1-1/2" O.D. DRAIN STUB 2 IN. OUT FROM WALL  
 UBICACION RECOMENDADA DE LA SALIDA DE DESECHOS. ADAPTADOR DE DESAGUE DE 1-1/2" DE DIAM. EXT., A 51 mm (2") DE LA PARED.  
 EMPLACEMENT RECOMMANDÉ DE L'ARRIVÉE D'EAU. TUBE EN CUIVRE NON PLAQUÉ DE 3/8 PO DE DIA. EXT. RACCORDER À LA CONDUITE D'ALIMENTATION AVEC UN ROBINET D'ARRÊT (NON FOURNI) À 76 mm (3 PO) MAXIMUM DU MUR  
 PRESION MÁXIMA D'ALIMENTATION EN EAU: 105 PSI (0.73 MPa)
  - C =** 1-1/2" TRAP NOT FURNISHED  
 (2 PO) HORS DU MUR  
 NO SE INCLUDEYEF SIFÓN DE 1-1/2" SIFÓN DE 1-1/2 PO NON FOURNI
  - D =** ELECTRICAL SUPPLY (3) WIRE RECESSED BOX DUPLEX OUTLET\*\*  
 SUMINISTRO ELÉCTRICO (3) CAJA ENCHUFE DE ALAMBRE SALIDA DUPLEX ALIMENTACION ELÉCTRICA (3) BÓTIER ENCASTRE
  - E =** INSURE PROPER VENTILATION BY MAINTAINING 6" (152 mm) (MIN) CLEARANCE FROM CABINET LOUVERS TO WALL.  
 PARA GARANTIZAR LA VENTILACIÓN ADECUADA, MANTENGA 152 mm (6") (MIN.) DE SEPARACIÓN DESDE LAS REJILLAS DEL GABINETE HASTA LA PARED.  
 POUR ASSURER UNE AÉRATION SUFFISANTE, PRÉVOIR UN DÉGAGEMENT DE 152 mm (6 PO) (MIN.) ENTRE LES ÉVÉNENTS DE L'ENCEINTE ET LE MUR
  - F =** 7/16 BOLT HOLES FOR FASTENING UNIT TO WALL  
 ORIFICIOS PARA PERNOS DE 7/16. PARA FIJAR LA UNIDAD A LA PARED.  
 TROUS DE VIS DE 7/16 PO POUR LA FIXATION DE L'APPAREIL AU MUR
- \*\*NEW INSTALLATIONS MUST USE GROUND FAULT CIRCUIT INTERRUPTER (GFCI)  
 \*\*Las nuevas instalaciones deben usar un interruptor de circuito de falla a tierra (GFCI)  
 \*\*Les nouvelles installations doivent comporter un disjoncteur différentiel (GFCI)

**ALTERNATE ROUGH-IN FOR RIGHT-HAND LOW, BOTTLE FILLER HIGH MODELS – REQUIRES BASIN ASSY CHANGE**

BOSQUEJO ALTERNATIVO PARA MODELOS CON LA LLENADORA DE BOTELLAS ALTA Y LA PARTE DERECHA BAJA: REQUIERE CAMBIAR EL CONJUNTO DE TARJA AUTRE DISPOSITION DE CANALISATIONS, POUR INSTALLATION DROITE BASSE ET REMPLISSEUSE DE BOUTEILLE HAUTE – MODIFICATION DE LA FONTAINE REQUISE

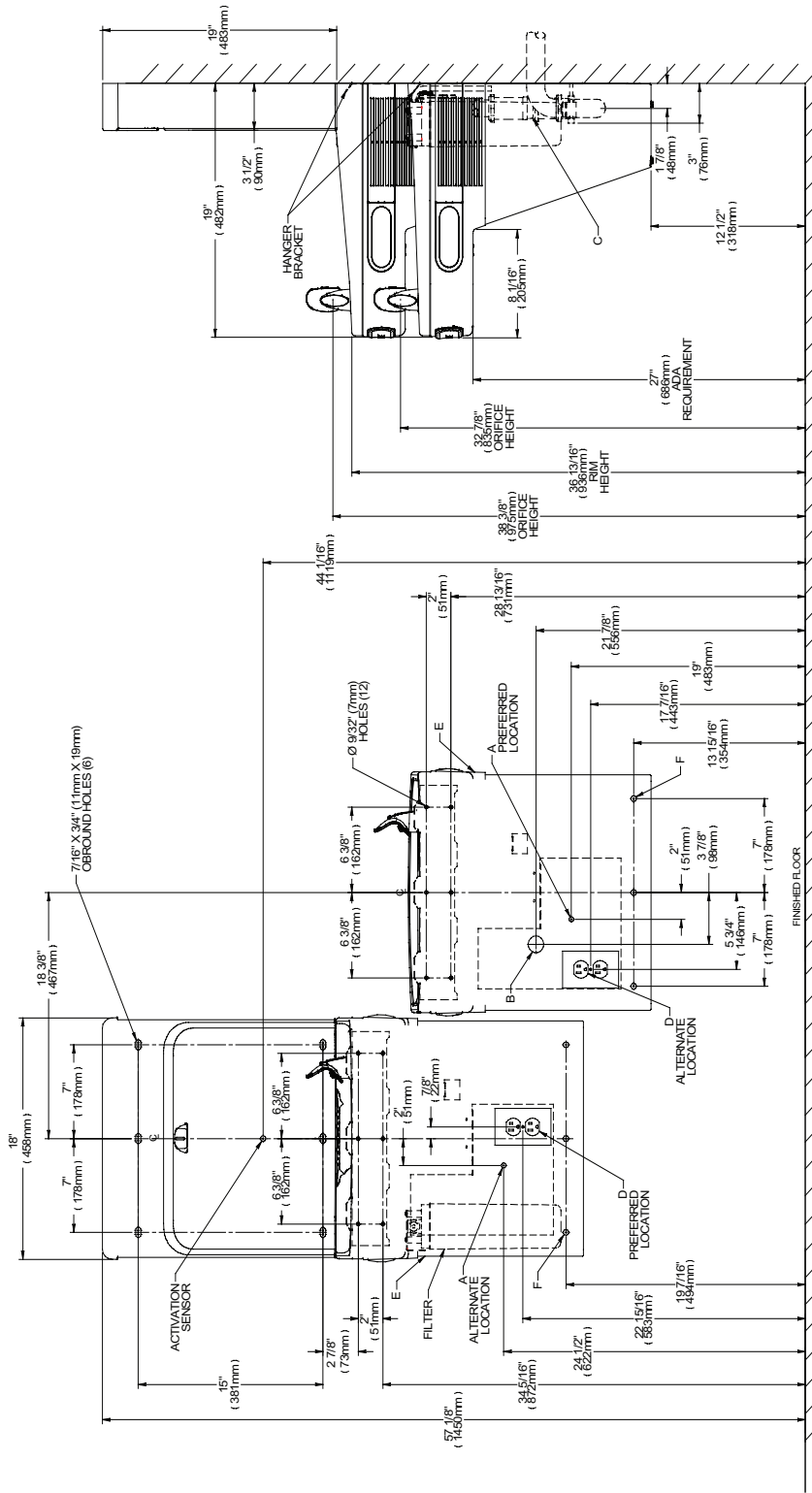

**FIG. 4**

**REDUCE HEIGHT BY 3 INCHES FOR INSTALLATION OF CHILDREN'S ADA COOLER**  
 REDUZCA LA ALTURA EN 76 mm (3") PARA LA INSTALACIÓN DEL BEBEDERO CON CLASIFICACIÓN ADA PARA NIÑOS  
 RÉDUIRE LA HAUTEUR DE 76 mm (3 PO) POUR LES INSTALLATIONS À LA NORME ADA ENFANTS

**NOTE: TO COMPLETE THIS OPTION, THE VERSATILE BF BASIN KIT (VERSATILEBFKIT) MUST BE ORDERED SEPARATELY.**  
**NOTA: PARA COMPLETAR ESTA OPCIÓN, SE DEBE PEDIR POR SEPARADO EL KIT DE LAVABO POLYVALENT BF (VERSATILEBFKIT).**  
**REMARQUE: POUR COMPLETER CETTE OPTION, LE KIT DE LAVABO POLYVALENT BF (VERSATILEBFKIT) DOIT ÊTRE COMMANDE SEPARÉMENT.**

**LEGEND/LEYENDA/LÉGENDE**

- A =** RECOMMENDED WATER SUPPLY LOCATION 3/8 O.D. UNPLATED COPPER TUBE CONNECT STUB WITH SHUT OFF (BY OTHERS) 3 IN. (76mm)  
 MAXIMUM OUT FROM WALL, MAXIMUM WATER SUPPLY PRESSURE: 105 PSI (0.73 MPa)  
 UBICACIÓN RECOMENDADA DEL SUMINISTRO DE AGUA, TUBERÍA DE COBRE SIN REVESTIMIENTO DE 3/8" DE DIÁM. EXT. ADAPTADOR DE CONEXIÓN CON VÁLVULA DE CIERRE (DE TERCEROS) MÁXIMO A 76 mm (3") DE LA PARED.
- B =** RECOMMENDED LOCATION FOR WASTE OUTLET 1-1/2" O.D. DRAIN STUB 2 IN. OUT FROM WALL.  
 UBICACIÓN RECOMENDADA DE LA SALIDA DE DESECHOS, ADAPTADOR DE DESAGÜE DE 1-1/2" DE DIÁM. EXT., A 51 mm (2") DE LA PARED.
- C =** 1-1/2" TRAP NOT FURNISHED  
 (2 PO) HORS DU MUR  
 NO SE INCLUDE SIFON DE 1-1/2"  
 SIPHON DE 1-1/2 PO. NON FOURNI
- D =** ELECTRICAL SUPPLY (BY WIRE RECESSED BOX DUPLEX OUTLET\*\*)  
 SUMINISTRO ELÉCTRICO (3 CAÑEROS DE UN AMBOS SALIDA DÚPLEX)
- E =** INSURE PROPER VENTILATION BY MAINTAINING 6" (152 mm) (MIN.) CLEARANCE FROM CABINET LOUVERS TO WALL.  
 PARA GARANTIZAR LA VENTILACIÓN ADECUADA, MANTENGA 152 mm (6") (MÍN.) DE SEPARACIÓN DESDE LAS REJILLAS DEL GABINETE HASTA LA PARED.  
 POUR ASSURER UNE AÉRATION SUFFISANTE, PRÉVOIR UN DÉGAGEMENT DE 152 mm (6 PO) (MÍN.) ENTRE LES ÉVÉNEMENTS DE L'ENCEINTE ET LE MUR.
- F =** 7/16" BOLT HOLES FOR FASTENING UNIT TO WALL.  
 ORIFICIOS PARA PEROS DE 7/16" PARA FIJAR LA UNIDAD A LA PARED.  
 TROUS DE VIS DE 7/16" POUR LA FIXATION DE L'APPAREIL AU MUR.

- D =** ELECTRICAL SUPPLY (BY WIRE RECESSED BOX DUPLEX OUTLET\*\*)  
 SUMINISTRO ELÉCTRICO (3 CAÑEROS DE UN AMBOS SALIDA DÚPLEX)
- E =** INSURE PROPER VENTILATION BY MAINTAINING 6" (152 mm) (MIN.) CLEARANCE FROM CABINET LOUVERS TO WALL.  
 PARA GARANTIZAR LA VENTILACIÓN ADECUADA, MANTENGA 152 mm (6") (MÍN.) DE SEPARACIÓN DESDE LAS REJILLAS DEL GABINETE HASTA LA PARED.  
 POUR ASSURER UNE AÉRATION SUFFISANTE, PRÉVOIR UN DÉGAGEMENT DE 152 mm (6 PO) (MÍN.) ENTRE LES ÉVÉNEMENTS DE L'ENCEINTE ET LE MUR.
- F =** 7/16" BOLT HOLES FOR FASTENING UNIT TO WALL.  
 ORIFICIOS PARA PEROS DE 7/16" PARA FIJAR LA UNIDAD A LA PARED.  
 TROUS DE VIS DE 7/16" POUR LA FIXATION DE L'APPAREIL AU MUR.

\*\*NEW INSTALLATIONS MUST USE GROUND FAULT CIRCUIT INTERRUPTER (GFCI)  
 \*\*Las nuevas instalaciones deben usar un interruptor de circuito de falla a tierra (GFCI)  
 \*\*Les nouvelles installations doivent comporter un disjoncteur différentiel (GFCI)

**INSTRUCTIONS FOR REMOVING WRAPPER**

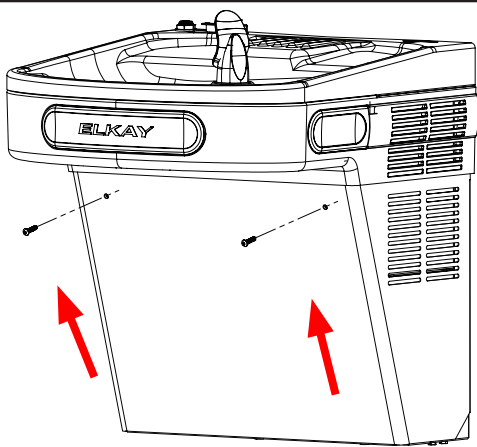

**Fig. D(i)**

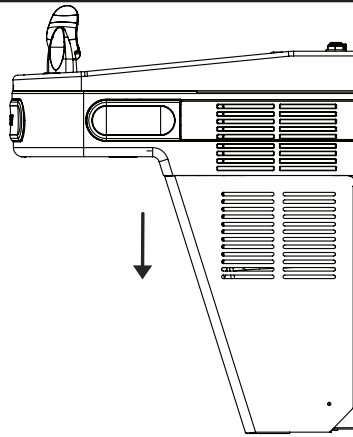

**Fig. D(ii)**

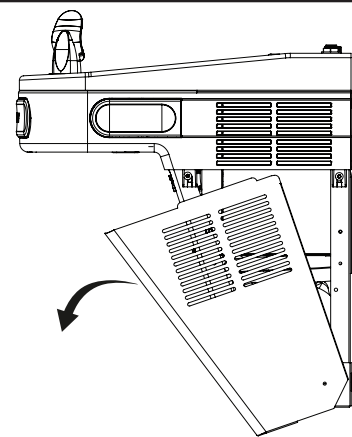

- 1) Remove the two security screws (size T25) from the front panel. (see Fig D(i)).  
**NOTE: SCREW THREADS INTO BUSHING WHILE ANGLED. DO NOT ATTEMPT TO THREAD SCREW INTO BUSHING HORIZONTALLY.**
- 2) Gently pull the wrapper down and rotate the wrapper to a downward position (see Fig D(ii)).
- 3) To remove the wrapper, hold each side and gently pull wrapper up and out of pivoting bracket (see Fig D(iii)).

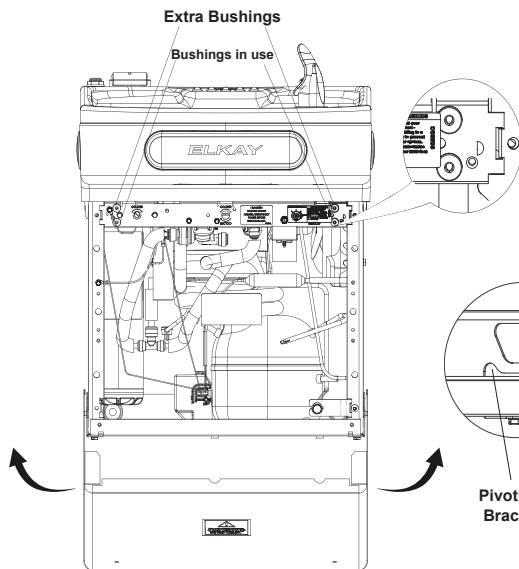

**Fig. D(iii)**

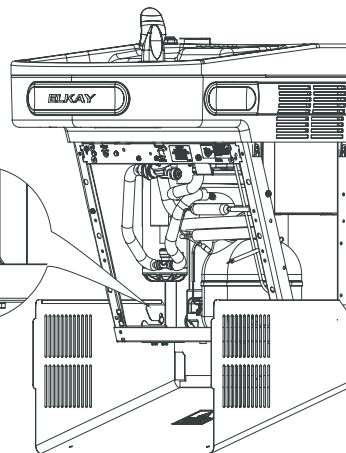

**Fig. D(v)**

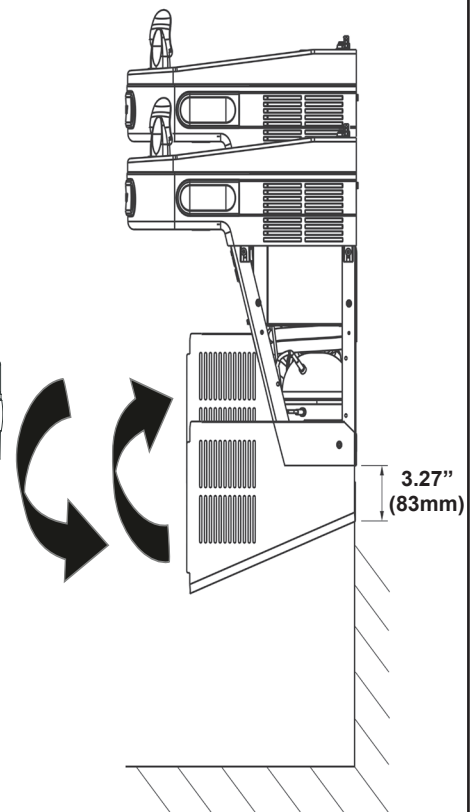
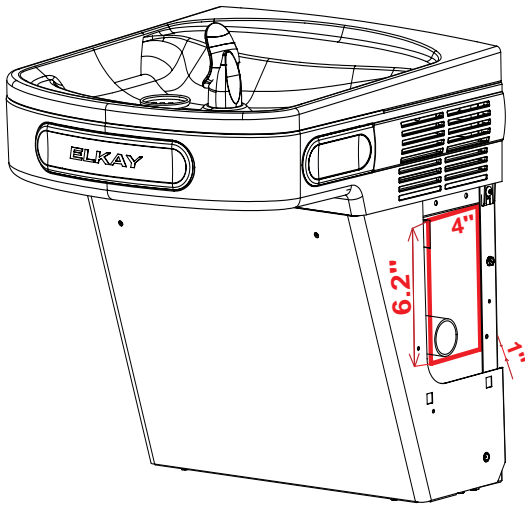

**Fig. D(iv)**

- CAUTION:** WRAPPER DROPS AND SWINGS WHEN SECURITY SCREWS ARE REMOVED.
- CAUTION:** DO NOT LEAN ON WRAPPER.
- CAUTION:** DO NOT USE POWER TOOL TO TIGHTEN. DO NOT OVERTIGHTEN.

**NOTE:**

1. Ensure that there are no plumbing or external objects below the wrapper in the specified dimension. The specified (3.27") minimum distance is required for the wrapper to swing out (see Fig D(iv)).
2. Removing the wrapper from the pivoting bracket when servicing the unit is recommended. The wrapper may be left in place for quick serviceability (see Fig D(iii)).
3. When re-attaching wrapper, ensure each side of wrapper is engaged to pivoting bracket (see Fig D(v)).
4. Once the wrapper is in place, rotate wrapper up and under the shroud. Ensure thru holes on wrapper are aligned with plastic bushing threads on the frame prior to engaging security screws. Ensure screw is angled relative to the ground and perpendicular to wrapper surface prior to engagement. Hand tighten prior to using hand tool to avoid cross-threading.
5. Four plastic bushings are located in the cross brace of the frame. The lower two bushings align with wrapper holes and the top two bushings are extras in case of replacement (see Fig D(iii)).



**Fig. E**

**NOTE:**

The highlighted portion in red color is acceptable plumbing rough-in for installation.

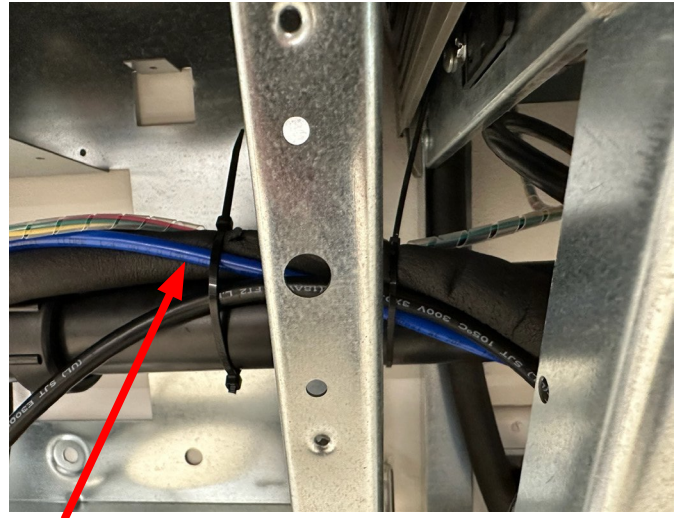

**Fig. F**

**NOTE:**

To mitigate the wrapper rotation interferences, zip tie lines (plumbing and electrical) running between the cooler units to the waste line (PVC pipe).

**HANGER BRACKETS INSTALLATION**

- 1) Remove hanger bracket fastened to back of coolers by removing one (1) screw.
- 2) Determine your mounting configuration from the figures shown on pages 2 - 5. Refrigeration unit must be on right hand side.

**IMPORTANT NOTE: If the Bottle Filler is to be mounted on the left hand cooler, a basin assembly change will be needed.**

**Determine your configuration by referring to the Configuration Instructions on page 10 prior to continuing.**

- 3) Mount the hanger bracket as shown in Figures 1 - 4 (Pages 2 - 5).

**NOTE:** Hanger Bracket **MUST** be supported securely. Add fixture support carrier if wall will not provide adequate support. Anchor hanger securely to wall using all six (6) 1/4 in. dia. mounting holes.

**IMPORTANT:** 5-7/8 in. (150 mm) dimension from wall to centerline of trap must be maintained for proper fit.

**INSTALLATION OF COOLER**

- 4) Refer Fig D(i) to D(iv), Pg. 6 for wrapper removing instructions.
- 5) Hang only the refrigerated cooler on the hanger bracket. Be certain hanger bracket is properly in the slots on the cooler backs as shown in Figures 1 (Pg. 2), 2 (Pg.3), 3 (Pg. 4), and 4 (Pg. 5).
- 6) Hang the non-refrigerated cooler on the hanger bracket. Be certain hanger bracket is engaged properly in the slots on the cooler backs as shown in Figures 1 (Pg. 2), 2 (Pg. 3), 3 (Pg. 4), and 4 (Pg. 5).
- 7) Unband the loose wires in the refrigerated cooler for the filter communication board. Stretch it out and thread through the left side of the refrigerated cooler and into the right side of the non-refrigerated cooler. Plug into the filter communication board that is behind the filter head.
- 8) Secure each cooler frame to wall by installing (2) screws and washers (not supplied) in lower holes. See pictures below.

**Make sure the screws engage in a structural member.**

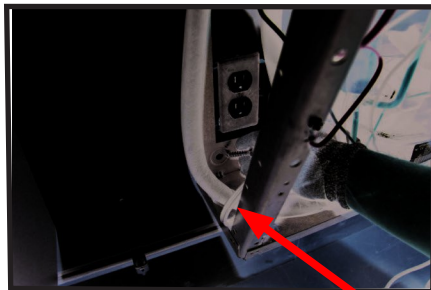

**FIG. 6**

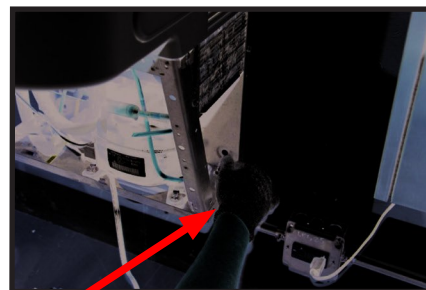

**FIG. 7**

- 9) Connect the supply water to the filter 3/8" copper inlet tube.
- 10) Connect the waterline from the outlet of the filter to the inlet of the evaporator in the refrigerated cooler by inserting it into the quick connector.
- 11) Connect the waterline from the solenoid in the non-refrigerated cooler to the open 1/4" inch tee fitting in the refrigerated cooler.
- 12) Find your cooler configuration on page 11 and connect the drain assembly together.
- 13) Install trap.

**IMPORTANT:** If it is necessary to cut the drain, loosen the screw at the black rubber boot and remove tube, check for leaks after re-assembly.

**BOTTLE FILLER INSTALLATION**

- 14) Remove two (2) mounting screws with 5/32" Allen wrench holding Bottle Filler to wall mounting plate (See Fig. 8). Note do not discard mounting screws, they will be needed to secure Bottle Filler to wall mounting plate.
- 15) Remove wall mounting plate from Bottle Filler (See Fig. 8 ). Place wall mounting plate against wall on top of basin. Center the wall mounting plate side to side with the basin. Mark the six (6) mounting holes with a pencil (See Fig. 1, Pg. 2). Place tape over wiring harness connection on top of cooler to prevent debris from falling into Connection(See Fig. 6, Pg. 7).
- 16) Remove wall mounting plate from wall. **NOTE:** Mounting plate **MUST** be supported securely. Add fixture support carrier if wall will not provide adequate support.
- 17) Install wall mounting plate to wall using six (6) 7/16" obround mounting holes (mounting bolts not included) (See Fig. 7, Pg. 7). Use appropriate fasteners for your wall type.
- 18) Install gasket on bottom of Bottle Filler with gasket support bracket & (2) screws. (See Fig. 8).

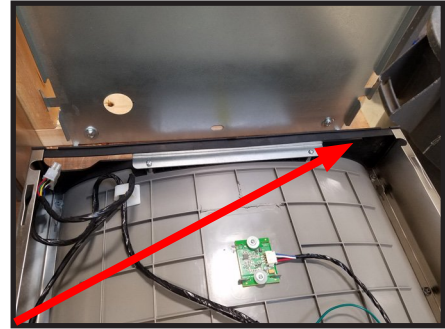

**FIG. 8**

- 19) Route 3/8" tubing through the opening in the bottle filler gasket and plug into bulkhead fitting in basin. Route the wiring harness through the gasket and plug into the connector on the top of the basin. Water line should be cut to length prior to attaching to bulkhead fitting.
- 20) Place Bottle Filler on the four (4) hooks on the mounting plate installed on wall.

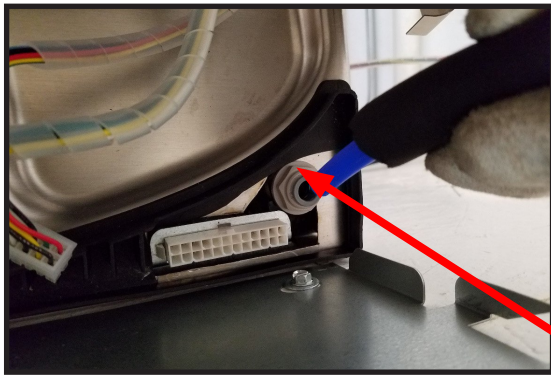

**Gasket removed from bottle filler for clarity.**

**Fig. 9**

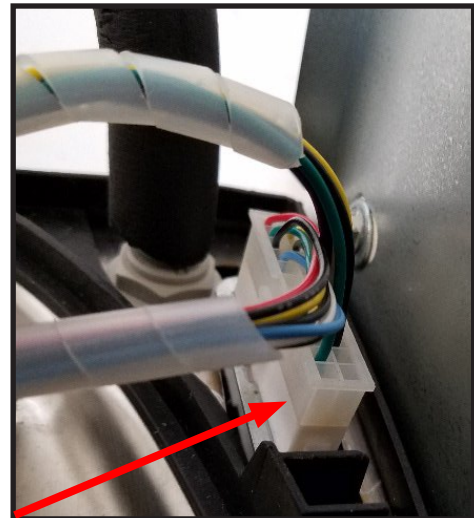

**Gasket removed from bottle filler for clarity.**

**Fig. 10**

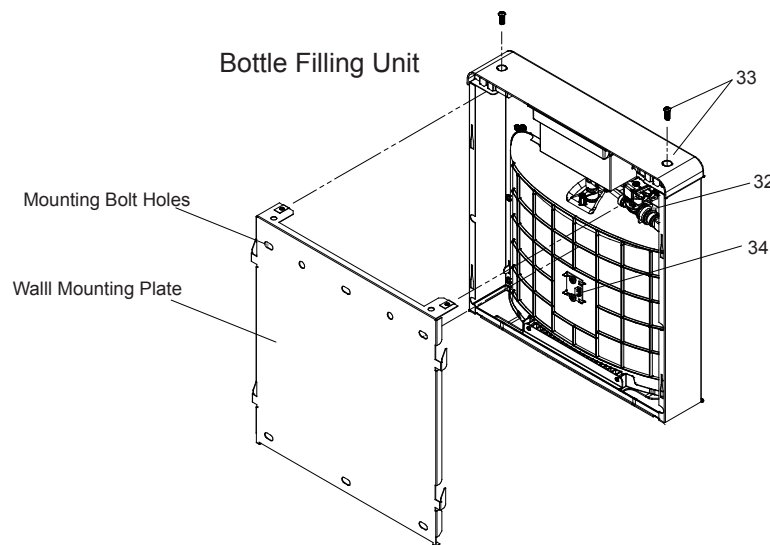

**FIG. 11**

**FINAL INSTALLATION (FILTER)**

- 21) Remove filter from carton, remove protective cap, attach filter to filter head by firmly inserting into head and rotating filter clockwise. Ensure that front facing label can be read when filter is installed. (See Fig. 12)
- 22) Turn water supply on and inspect for leaks. In both cooler and Bottle Filler. Fix all leaks before continuing.
- 23) Once cooler and bottle filter have been inspected for leaks and any leaks corrected, plug cooler into wall.
- 24) Reinstall two mounting screws from first step above. Caution do not over tighten screws.
- 25) Once power is applied to the cooler the BLUE LED light will illuminate on the bottle filler showing good filter status along with the LCD Bottle Counter.
- 26) Verify proper dispensing by placing cup, hand, or any opaque object in front of sensor area and verify that the water dispenses. Note: the first initial dispenses might have air in line which may cause a sputter and hazy appearance. Run water and flush filter to purge air and fine carbon particles from filter before use. This will be eliminated when all air is purged from the line.
- 27) Once unit tests out, install Lower Panels back on water coolers. (See pages 12-13 for versatile wrapper installation).
- 28) When re-attaching wrapper, push wrapper up and under the shroud. Make sure wrapper and bushing holes are aligned prior to inserting screw. Units are now ready for use.



**FIG. 12**

**Note: Danger! Electrical shock hazard. Disconnect power before servicing unit.**

**INSTRUCTIONS FOR REPLACING FILTERS**

- 1) Refer Fig D(i) to D(iv), Pg. 6 for wrapper removing instructions.
  - 2) Turn off water supply; dispense water to relieve pressure.
  - 3) Disconnect electrical power by unplugging unit's power cord.
  - 4) Turn used filter counterclockwise 1/4 turn to remove from filter head.
  - 5) Remove cap from new filter and use to seal used filter.
  - 6) Insert new filter into existing filter head and turn fully clockwise. Make sure you can read the label on the front of the filter once it is installed. (See Fig. 12).
  - 7) Connect electrical power by plugging in unit's power cord.
  - 8) Turn on water supply and run water and flush filter to purge air and fine carbon particles from filter before use. Visit [elkay.com/filtration](http://elkay.com/filtration) for additional details. Also run water through bottle filler until all air is removed and water flow is clear.
- Note:** Filter status light will automatically reset once new filter is installed.

**INSTRUCTIONS TO ACCESS PROGRAMMING BUTTON**

- 1) Remove lower cover on refrigerated unit by removing (2) screws.
- 2) Button is located in lower right corner of unit (See Fig. 13).

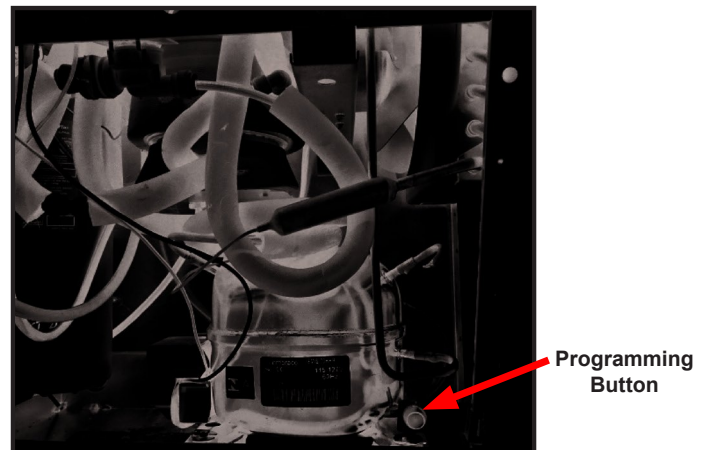

**FIG. 13**

## CONFIGURATION INSTRUCTIONS

### INSTRUCTIONS TO MOVE THE BOTTLE FILLER & BASIN TO THE LEFT SIDE (NON-REFRIGERATED) FOR ALTERNATE MOUNTING VERSATILE BI-LEVEL

NOTE: TO COMPLETE THIS OPTION, THE VERSATILE BF BASIN KIT (VERSATILEBFKIT) MUST BE ORDERED SEPARATELY.

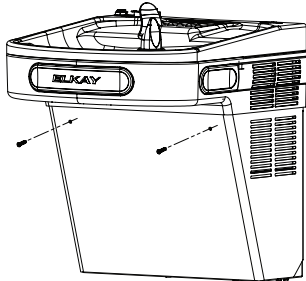
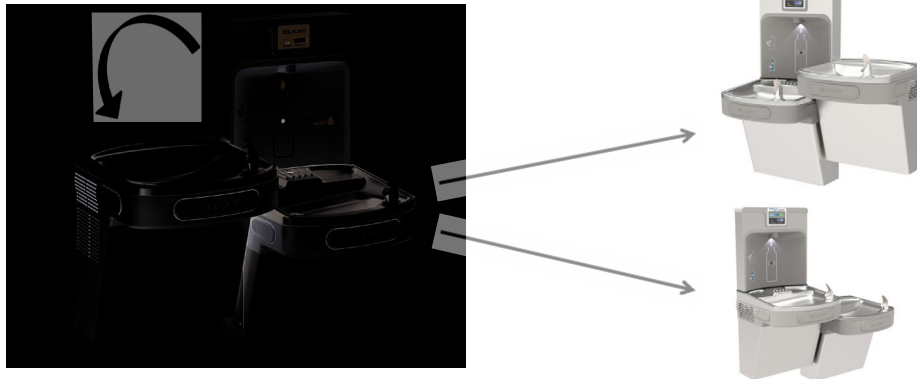

Fig. A

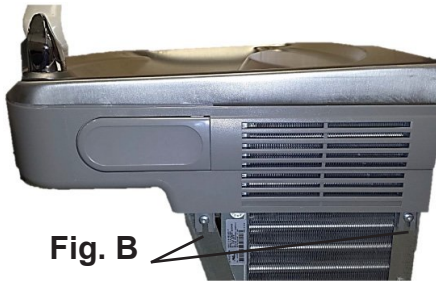

Fig. B

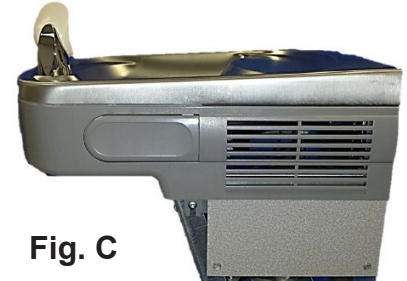

Fig. C

**ONLY move the filler panel and j-clip to the refrigerated (right) side if right side will be mounted "high"**

1. Refer Fig D(i) to D(iv), Pg. 6 for wrapper removing instructions.
2. Remove filler panel from cooler using a 5/16" socket.
3. Using a T25 (6-point star) bit, loosen the shroud screws on both sides of both coolers.
4. Lift the basin/shroud assembly from each cooler. Disconnect the water line from the solenoid and the shroud wires from the wiring harness and solenoid. Set aside.
5. Unfasten the electrical harness connector from the electrical bracket.  
Using a T25 (6-point star) bit, remove the electrical bracket from the mounting bracket. Snap the electrical harness connector into the cutout of the mounting bracket with the connector facing down. (See Fig 14.)
6. Install the electrical bracket on the filter bracket of the non-refrigerated cooler by removing the two screws towards the front of the cooler and reinstalling them through the bracket. Attach the female end of the bi-level extension into the electrical bracket.
7. Only move the filler panel and J-clip to the refrigerated (right) cooler if the right side will be mounted high.
8. Install the non-bottle filler basin on the refrigerated cooler. Connect the water line to the solenoid and the electrical connections to the wiring harness and solenoid. Tighten the (4) T25 screws.
9. Mount the refrigerated cooler on the right-hand hanger bracket. Secure to wall.
10. Install the bottle filler basin on the non-refrigerated cooler. Connect the water line to the solenoid and the electrical connections to the wiring harness and solenoid. Be certain the electrical connector is protruding through the cutout in the top of the basin. Tighten the (4) T25 screws.
11. Mount the non-refrigerated cooler on the left-hand hanger bracket. Secure to wall.
12. Route the bi-level extension through the coolers and connect to the refrigerated electrical harness mounted in the mounting bracket (See Figs. 15 & 16).
13. Hook up the drains using the attached drain kit.
14. Make all water and electrical connections.
15. Reinstall wrappers using (2) screws for each wrapper.

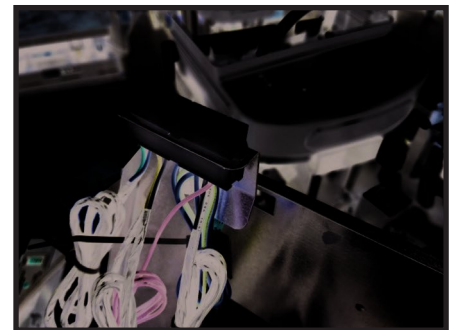

FIG. 14

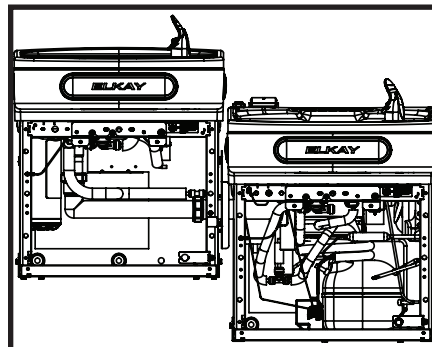

FIG. 15



FIG. 16

**Refrigerated Cooler side:**

Carefully lift and tip the shroud/basin assembly off the cooler frame.

Only disconnect the (2) black wires coming from the shroud assembly that go to the solenoid valve and to the cold control.

Disconnect the water line at the solenoid valve. Reference (See Fig. 20, Pg.15) for the operation of the quick connect fittings.

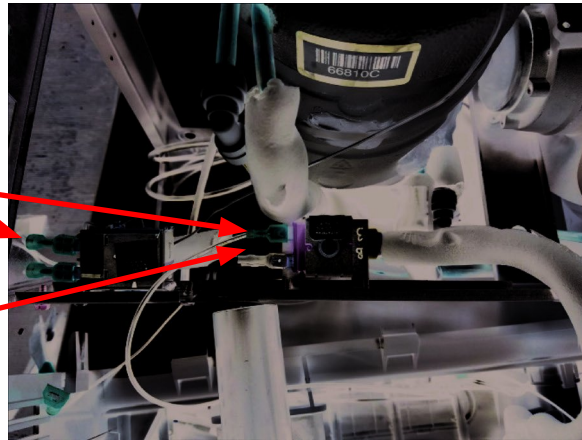

FIG.17

**Non-Refrigerated Cooler side:**

Carefully tip the shroud/basin assembly toward the cooler frame.

Connect one of the black wires to the solenoid valve and one to the power cord.

Re-connect the water line at the solenoid. Reference (See Fig. 20, Pg.15) for the operation of the quick connect fittings.

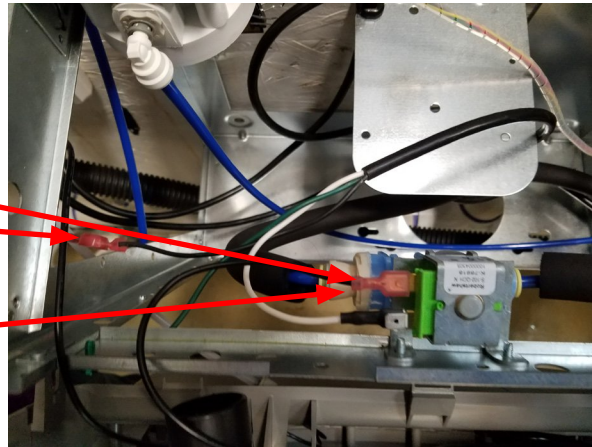

FIG.18

**Swap drain parts in shroud:** Loosen each hose clamp retaining the drain pieces. Remove each drain piece and swap to other basin. Tighten each hose clamp.

**Enhanced EZH2O Error Codes**

Error Code	Error Description	Corrective Action
	Please clear Bottle Filler	<ul style="list-style-type: none"> <li>Remove obstruction</li> <li>Clean lens on IR sensor</li> <li>Unplug unit for at least 30 seconds and restart</li> <li>If error repeats, replace IR sensor</li> </ul>
E013	Missing or Incompatible Filter	<ul style="list-style-type: none"> <li>Check that filter is installed correctly (label facing forward, round blue tag facing NFC Board)</li> <li>Unplug unit for at least 30 seconds and restart</li> <li>Replace filter</li> <li>Replace filter head assembly with repair kit</li> <li>If error repeats, contact certified service professional</li> </ul>
E013 & E014	Missing/Unplugged NFC Board	<ul style="list-style-type: none"> <li>Unplug unit for at least 30 seconds and restart</li> <li>Verify cable connector is plugged into NFC board on filter head assembly</li> <li>Replace filter head assembly with repair kit</li> <li>If error repeats, contact certified service professional</li> </ul>

# PLUMBING DIAGRAMS VERSATILE BI-LEVEL

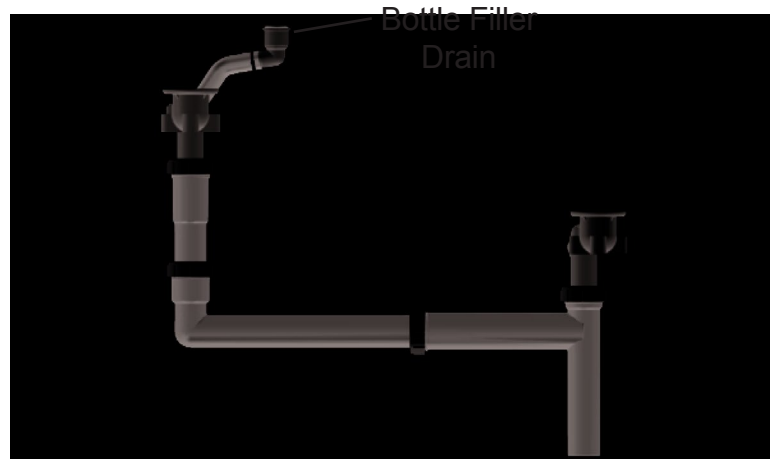
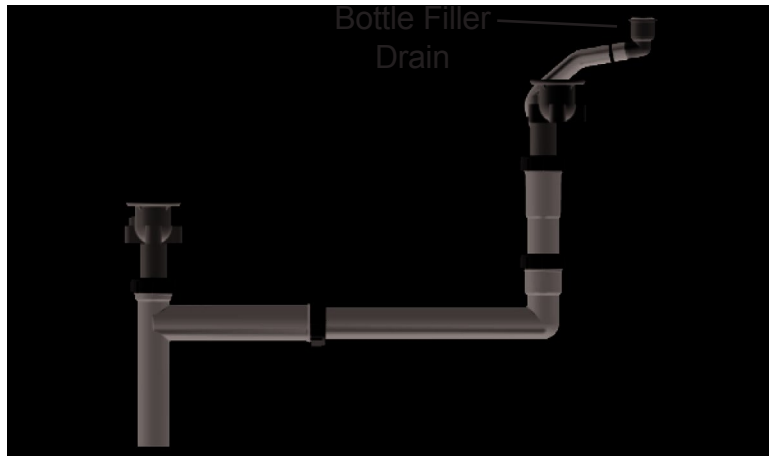
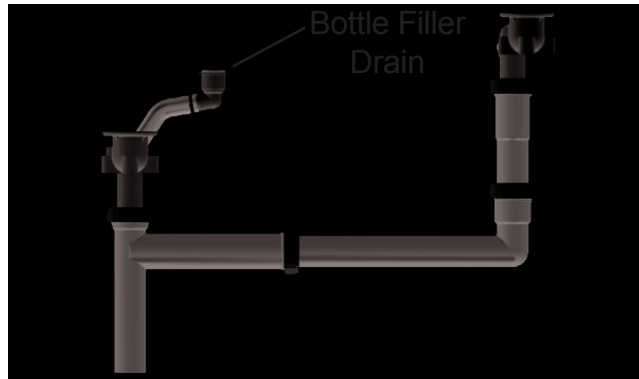
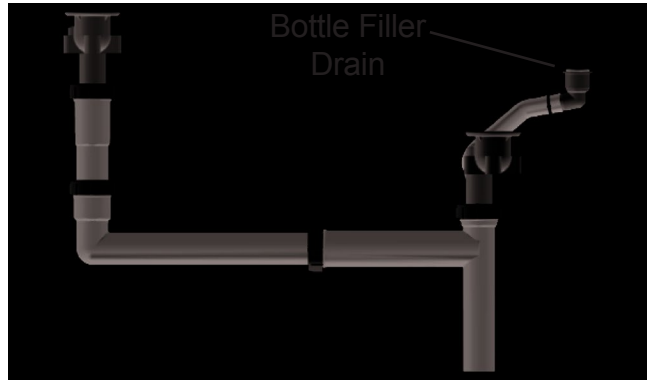

## Versatile Wrapper Installation Instructions

### Right Hand Wrapper (Low Side)

- 1) Remove the (2) screws from the wrapper, rotate the wrapper down, and remove.
- 2) Clip cover plate, sliding until plate sits flush with the wall.
- 3) Re-install wrapper with (2) screws.
- 4) Dispose of unused trim piece.

### Revestimiento del lado derecho (Lado bajo)

- 1) Retire los (2) tornillos del envoltorio, gire el envoltorio hacia abajo, y quitar.
- 2) Sujete la placa de la cubierta, deslizándola hasta que quede alineada con la pared.
- 3) Vuelva a instalar el revestimiento con los (2) tornillos.
- 4) Deseche la pieza de acabado que no usa.

### Enveloppe droite (côté gauche)

- 1) Retirez les (2) vis de l'emballage, faites pivoter l'emballage vers le bas, et supprimer.
- 2) Encliqueter la plaque de fermeture, en la glissant jusqu'au ras du mur.
- 3) Remonter l'enveloppe avec quatre (2) vis.
- 4) Jeter la pièce de garniture inutilisée.

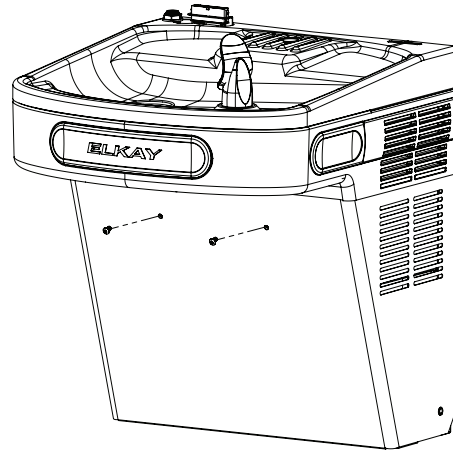
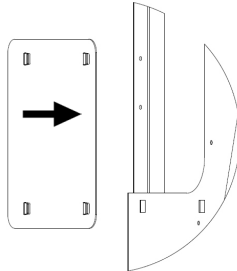

### Wrapper Fill Piece Location (Left Side High)

### Ubicación de la pieza de llenado del recubrimiento (lado izquierdo alto)

### Emplacement de la pièce de fermeture d'enveloppe (côté gauche haut)

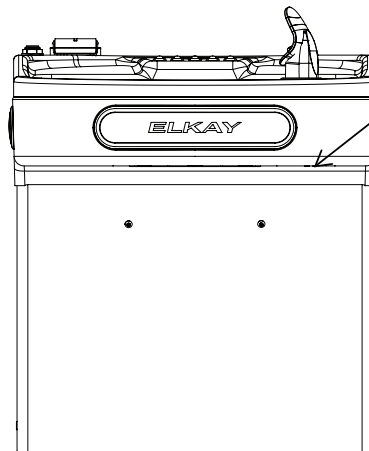

## Versatile Wrapper Installation Instructions continued. . .

Instrucciones de instalación de envoltura versátil continuadas. . .

Instructions d'installation de l'enveloppe polyvalente (suite). . .

### **Left Hand Wrapper (Low Side)**

- 1) Remove the (2) screws from the wrapper, rotate the wrapper down, and remove.
- 2) Clip cover plate, sliding until plate sits flush with the wall.
- 3) Re-install wrapper with (2) screws.
- 4) Dispose of unused trim piece.

### **Revestimiento del lado izquierdo (Lado bajo)**

- 1) Retire los (2) tornillos de la envoltura, gírela hacia abajo y retírela.
- 2) Sujete la placa de la cubierta, deslizándola hasta que quede alineada con la pared.
- 3) Vuelva a instalar el revestimiento con los (2) tornillos.
- 4) Deseche la pieza de acabado que no usa.

### **Enveloppe gauche (côté bas)**

- 1) Retirez les (2) vis de l'emballage, faites pivoter l'emballage vers le bas, et supprimer.
- 2) Encliqueter la plaque de fermeture, en la glissant jusqu'au ras du mur.
- 3) Remonter l'enveloppe avec quatre (2) vis.
- 4) Jeter la pièce de garniture inutilisée.

### **Wrapper Fill Piece Location (Right Side High)**

**Ubicación de la pieza de  
llenado del recubrimiento  
(lado derecho alto)**

**Emplacement de la pièce  
de fermeture d'enveloppe  
(côté droit haut)**

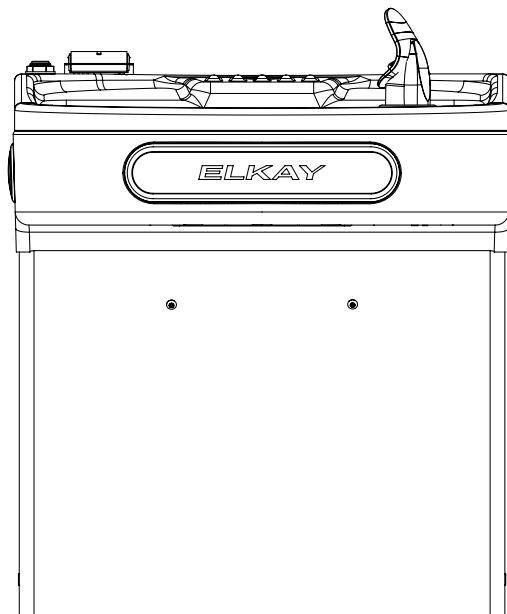
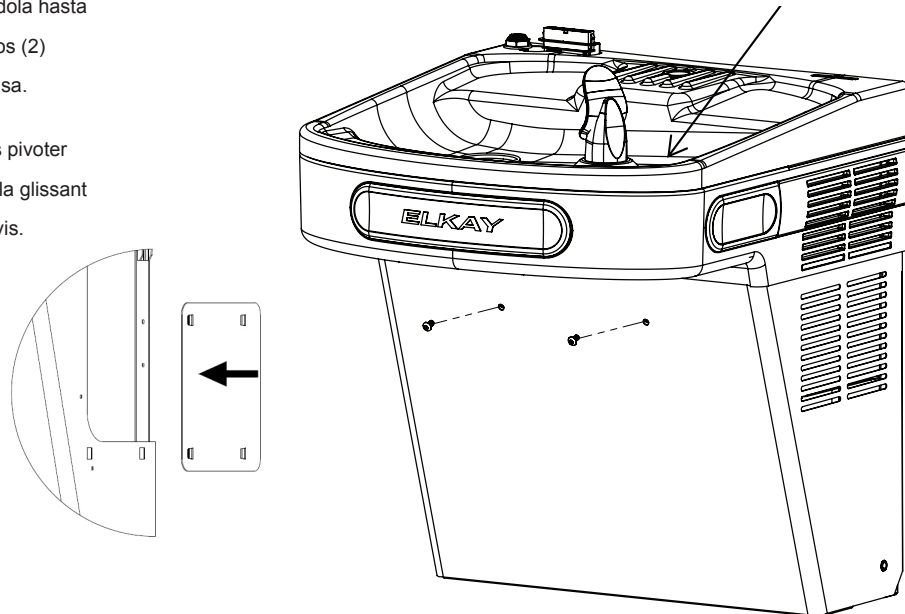

## 115V Refrigerated Wiring Diagram with Alpha/Numeric Display

### Enhanced Bottle Filling Station Electrical Diagram

LZSTL8WSAP  
LZSTL8WSAP-PF  
LZSTL8WSMP  
LZSTL8WSMP-PF  
LZSTL8WSSP-PF

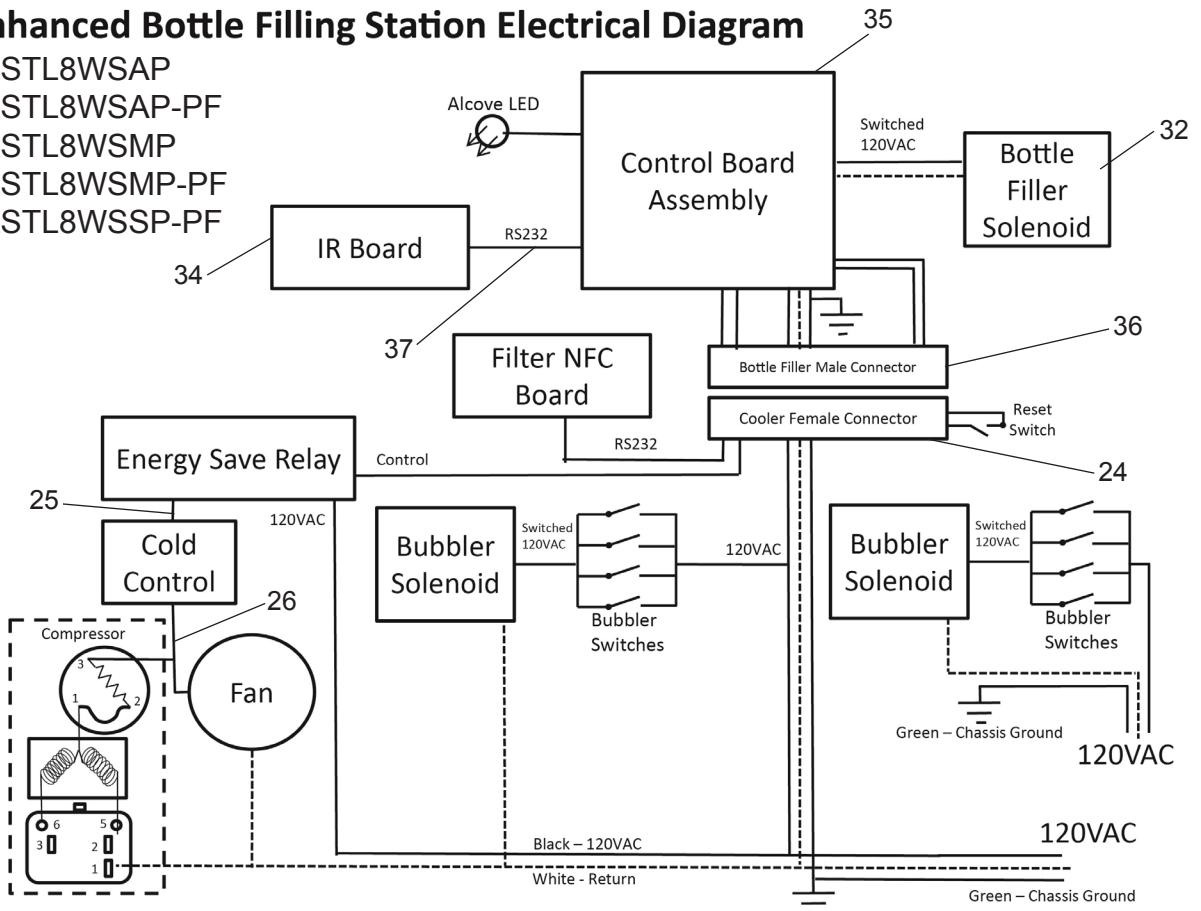
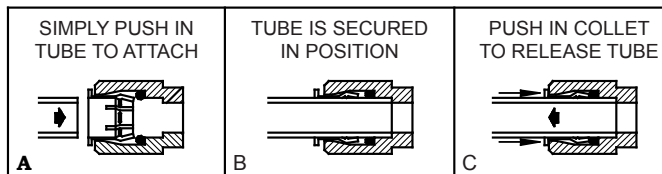

**Fig. 19**

**⚠ WARNING**

- **INGESTION HAZARD:** This product contains a button cell or coin battery.
- **DEATH** or serious injury can occur if ingested.
- A swallowed button cell or coin battery can cause **Internal Chemical Burns** in as little as **2 hours**.
- **KEEP** new and used batteries **OUT OF REACH** of CHILDREN
- **Seek immediate medical attention** if a battery is suspected to be swallowed or inserted inside any part of the body.

### OPERATION OF QUICK CONNECT FITTINGS



**Fig. 20**

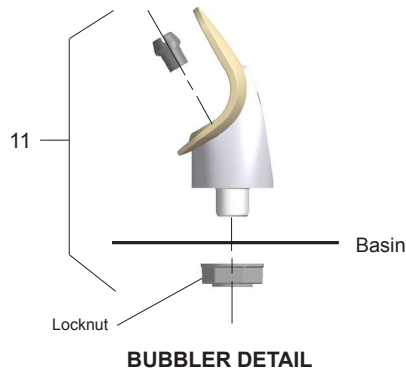

**Fig. 21**

**NOTE:**  
When installing replacement bubbler and pedestal, tighten nut only to hold parts snug in position. Do Not Overtighten.

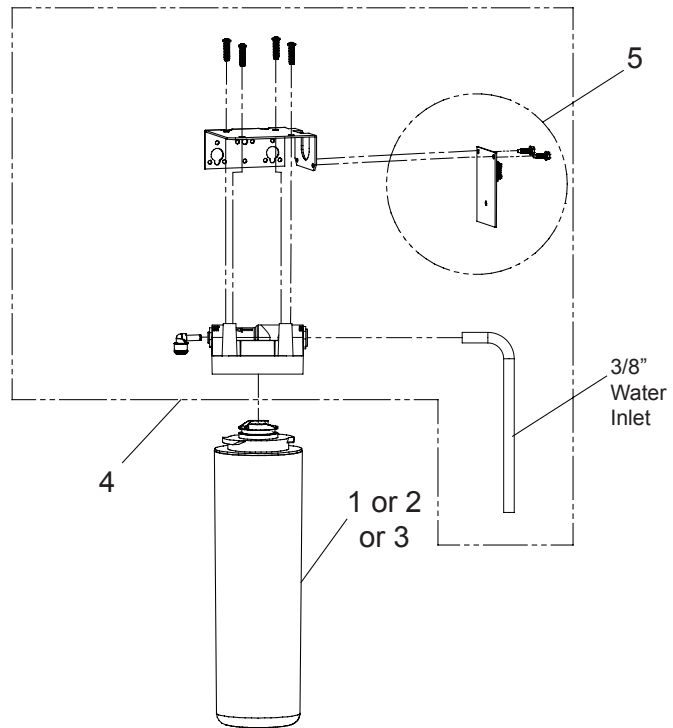

**Fig. 22**

**Note:**  
The filter status indicator shows the filter condition using colors. Blue indicates normal operation, no immediate attention needed. Red indicates immediate attention required to maintain proper function.



Scan for trouble shooting and to sign up for auto replenishment of authentic Elkay filters.



**Fig. 23**

**WATERSENTRY® Filter Detail**

WATERSENTRY® FILTER PARTS LIST		
ITEM NO.	PART NO.	DESCRIPTION
1	51300C	Filter 3000 Gal (standard)
2	51600C	Filter 6000 Gal (high capacity)
3	71300C	Filter 2250 Gal (PFOA/PFOS)
4	1000005214	Kit - Filter Head Fittings includes John Guest Fittings & 3/8" Elbow Filter Bracket/Screws
5	1000004409	Kit - NFC Board/Cover

**Note: Danger! Electrical shock hazard. Disconnect power before servicing unit.**

## Service Instructions

### Lower and Upper Shroud

To access the refrigeration system and plumbing connections, remove two (2) screws from front of cooler to remove the lower shroud. To remove the upper shroud for access to the pushbars, regulator, solenoid valve or other components located in the top of the unit, remove lower shroud, disconnect drain, remove four screws from tabs along lower edge of upper shroud, unplug two wires and water tube.

### Bubbler

To remove the bubbler, first disconnect the power supply. The underside of the bubbler can be reached through the access panel on the underside of the upper shroud. Remove the access panel by removing the retaining screw. To remove the bubbler, loosen locknut from the underside of the bubbler and remove the tubing from the quick connect fitting per the Operation Of Quick Connect Fittings section in the General Instructions. After servicing, replace the access panel and retaining screw.

### Switches Behind the Push Bar

The regulator in an EZ cooler is always held fully open by the use of a single regulator nut. Water is not dispensed until the pushbar is depressed to activate a switch which then opens a solenoid valve.

To remove sidebars, from the inside compress the flared tabs and pull out carefully. To reinstall side pushbars, the front of the pushbar is inserted first. While keeping the switch depressed, snap the rear of the pushbar into position.

## Cleaning

### Stainless Steel

- General cleaning: use an ordinary mild detergent and soft cloth, rinse and towel dry.
- Steel soap pads should never be used; particles can adhere to a stainless steel basin surface and will eventually rust.
- Light scratches are normal for stainless steel basins; over time they will blend into the uniform finish pattern.
- Do not use cleaners containing acids or chlorides, these will cause the stainless steel to oxidize.

### Plastic Components

- General cleaning: use an ordinary mild detergent and soft cloth, rinse and towel dry.
- Wiping the surface clean to remove debris or build up will not hurt the antimicrobial properties.

## Temperature Control

- Factory set at 50°F (+/- 5°F) under normal conditions. For altitude adjustments, refer to sticker on left side of top bar.

## Stream Height Adjustment

### VIEW OF UNDERSIDE OF BASIN SHROUD

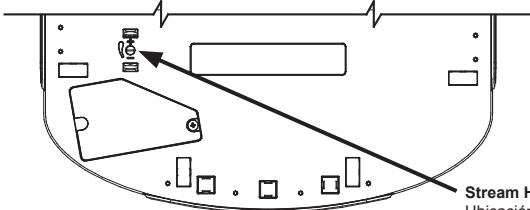

**Stream Height Adjustment Location**  
 Ubicación de ajuste de altura de corriente  
 Emplacement de réglage hauteur Stream

Refrigerated Unit

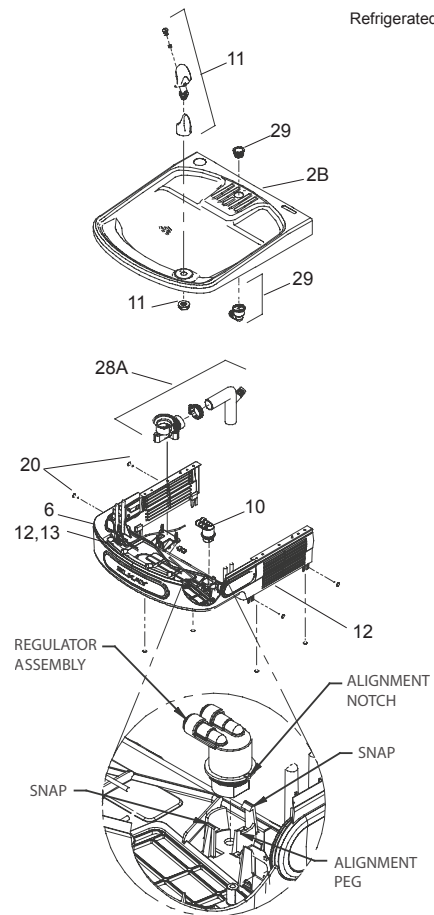

Fig. 24

Non-Refrigerated Unit

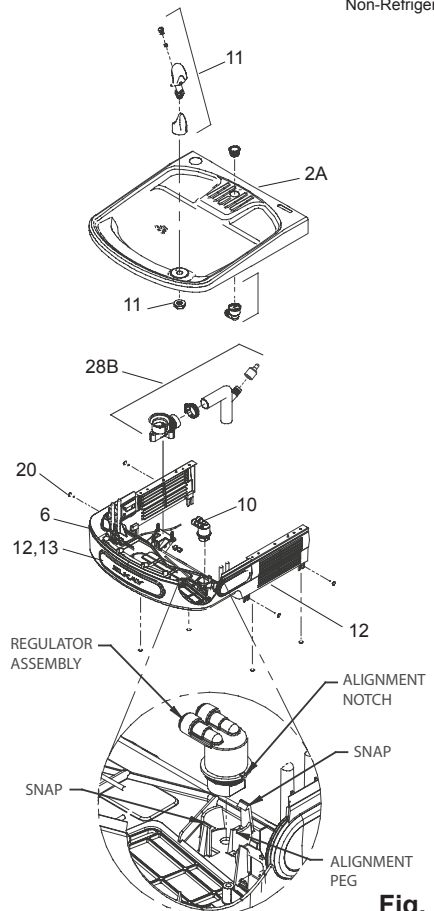

Fig. 25

## Programming Instruction

Depress Button for 3 seconds to activate main menu - release										
Cycles thru main menu items 2 seconds each for 2 cycles then exits menu unless selected										
Cycles thru sub menu items 2 seconds each for 2 cycles then returns to main menu unless selected										
Selections are saved when the menu is exited										
Top Level	Action	Sub Menu.1	Action	Sub Menu/action	Action	Sub Menu/action	Action	Sub Menu/action	Notes	End Action
Info	Momentary	Scrolls through all the settings on unit								Returns to Main Menu
Info	Momentary	Flashes error code								Returns to Main Menu
Set time	Momentary									Drops to next level when selected
		Day (Sunday-Saturday)	Momentary						Use push button to select the day on the display	Drops to next level when selected
		AM/PM	Momentary						Use push button to select AM or PM	Drops to next level when selected
		Hour (12 hour)	Momentary						Use push button to select Hour	Drops to next level when selected
		Min 0-69 in 5 minute increments	Momentary						Use push button to select closest minute	Returns to Main Menu
Filler	Momentary									Drops to next level when selected
		No	Momentary	Turn off filter status and errors					No Filter unit - Error codes related to filter status turned off	Returns to Main Menu
		Yes	Momentary	Default setting - Turn on filter status and errors					Filter status has default ON / Default has read write to filter, LED status display, filter error capability	Returns to Main Menu
Refrig	Momentary									Drops to next level when selected
		No	Momentary	Disables E/S relay sets bottle fill time to 1.5gpm					Refrigeration off	Returns to Main Menu
		Yes	Momentary	Default setting - Enables E/S relay - sets time to 1.1gpm					Refrigeration on	Returns to Main Menu
Range	Momentary									Drops to next level when selected
		1-10	Momentary	Default setting 5 - Adjusts distance from sensor the bottle needs to be before turning on or off the bottle filler					The lower the number, the closer to the sensor the bottle needs to be to activate	Returns to Main Menu
B-Light	Momentary									Drops to next level when selected
		25%	Momentary						The settings are for the brightness of the display and night light	Returns to Main Menu
		50%	Momentary							Returns to Main Menu
		75%	Momentary	Default Setting						Returns to Main Menu
		100%	Momentary							Returns to Main Menu
Enter/Save	Momentary									Drops to next level when selected
		Off	Momentary	Default Setting						Returns to Main Menu
		On	Momentary	Set Energy Save Schedule						Drops to next level when selected
								Select Weekday		Drops to next level when selected
										Drops to next level when selected
								Momentary	Select time on	Drops to next level when selected
								Momentary	Select time off	Drops to next level when selected
										Drops to next level when selected
								Select Week-end		Drops to next level when selected
										Drops to next level when selected
								Momentary	Select time on	Drops to next level when selected
								Momentary	Select time off	Returns to Main Menu

**Pictured is unit only without bottle filler.**

**Note: Danger! Electrical shock hazard. Disconnect power before servicing unit.**

Uses HFC-134A refrigerant

Usa refrigerante HFC-134A

Utilise du fluide frigorigène HFC-134A

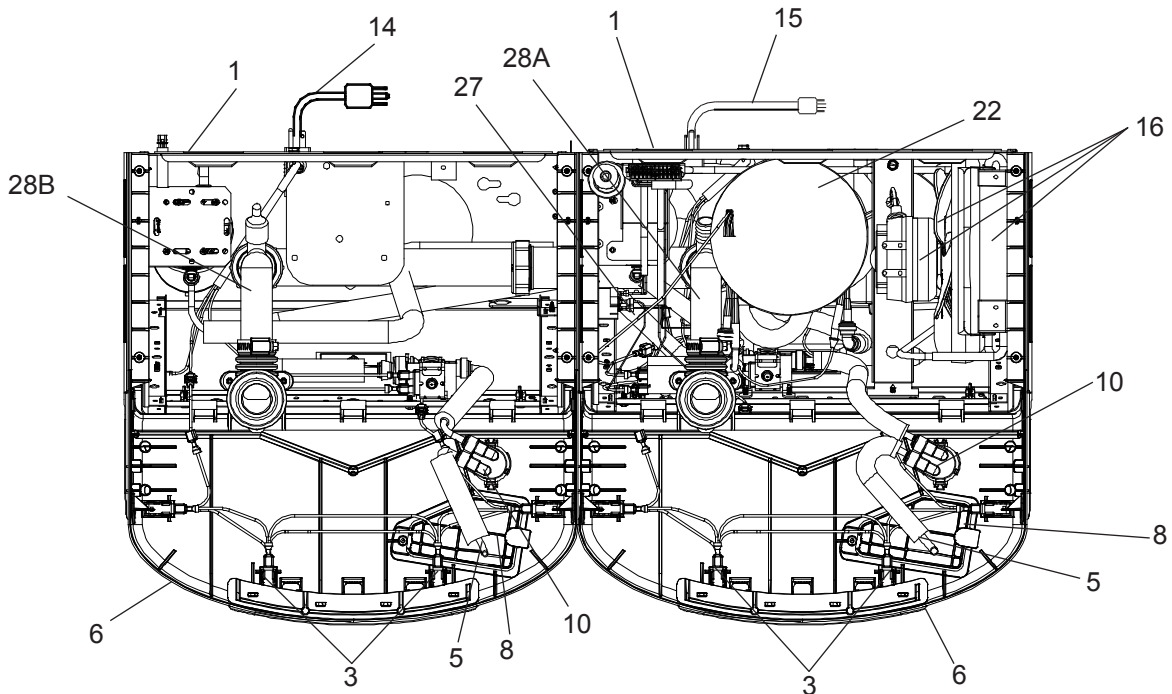

See Fig. 25

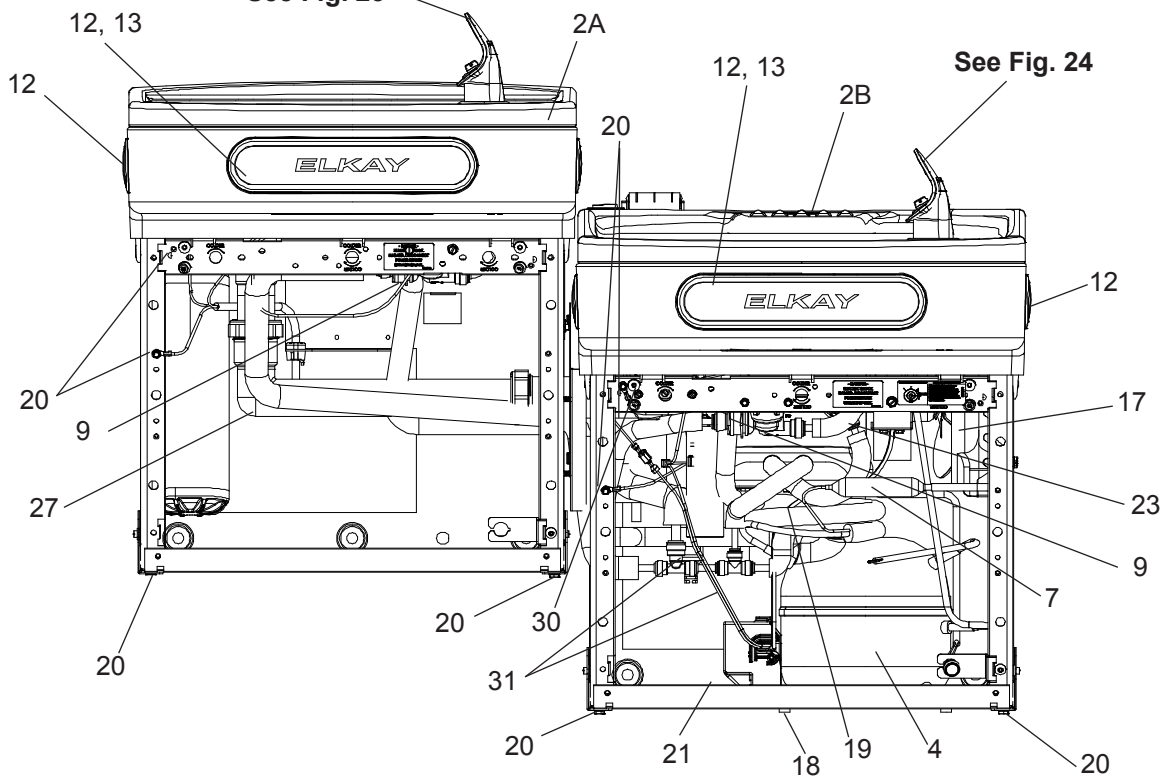

See Fig. 24

**Fig. 26**

**ATTENTION:**

If the product serial number is before 190424189, please refer to archived documents section of Elkay.com for the most accurate parts list. ([www.elkay.com/archived-documents](http://www.elkay.com/archived-documents))

**115V PARTS LIST / LISTA DE PIEZAS DE 115 V / LISTE DES PIÈCES 115 V  
LZSTL8WSAP, LZSTL8WSAP-PF, LZSTL8WSMP, LZS8TLWSMP-PF, LZS8TLWSSP-PF**

ITEM NO.	PART NO.	DESCRIPTION	DESCRIPCIÓN	DESCRIPTION
1	28401C	Hanger Bracket	Soporte colgante	Ferrure de suspension
2A	55001109	Basin - Stainless Steel	Tarja: Acero inoxidable	Cuve - Acier inoxydable
2B	000001337	Basin - Bottle Filler Stainless Steel	Tarja: Llenadora de botellas de acero inoxidable	Cuve - Remplisseuse de bouteille en acier inoxydable
3	36216C	Wiring - Front/Side Push Bar	Cableado: Barra de empuje delantera y lateral	Câblage - Poussoir frontal/latéral
*4	36322C	Compr - Service Pak 115V EMIS70HHR	Compresor: Paquete de servicio de 115 V EMIS70HHR	Compr - Ens. service 115 V EMIS70HHR
5	56092C	Tube - Poly (Cut To Length)	Tubería: Polietileno (corte a la longitud necesaria)	Tube - Poly (couper à la longueur)
6	2000001564	Assy - Arctic White Shroud - Upper (Front Side Push)	Conjunto - Cubierta blanca ártica - Superior (Empuje lateral delantero)	Assy - Arceau blanc arctique - Partie supérieure (poussée latérale avant)
	2000001859	Assy - Midnight Black Shroud - Upper (Front Side Push)	Conjunto - Cubierta negra medianoche - Superior (Empuje lateral delantero)	Assy - Midnight Black Shroud - Partie supérieure (poussée latérale avant)
	56229C	Assy - Shroud- Upper (Front Side Push) (Standard Gray)	Conjunto; recubrimiento; superior (Empuje delantero y lateral) (Standard Gray)	Carénage supérieur (poussoir frontal/latéral) (Standard Gray)
7	66703C	Drier	Secador	Déshydrateur
8	56213C	Access Panel	Panel de acceso	Panneau d'accès
9	1000004572	Kit - Solenoid Valve/Regulator Assembly	Kit - Conjunto de válvula solenoide / regulador	Kit - Assemblage électrovanne / régulateur
10	1000004564	Kit - Regulator / Holder / Nut	Kit regulador con soporte y tuerca	Kit régulateur avec support et écrou
11	2000002087	Kit - Flexi Bubbler (Arctic White)	Kit - Burbujeador flexible (Arctic White)	Kit - Barboteur flexible (Arctic White)
	2000002086	Kit - Flexi Bubbler (Midnight Black)	Kit - Burbujeador flexible (Midnight Black)	Kit - Barboteur flexible (Midnight Black)
	56073C	Kit - Flexi Bubbler (Standard Gray)	Kit - Burbujeador flexible (Standard Gray)	Kit - Barboteur flexible (Standard Gray)
12	2000002077	Kit - Pushbar (Front/Side) TL (Arctic White)	Kit: Barra de empuje (Delantera y lateral) TL (Arctic White)	Trousse - Poussoir (frontal/latéral) TL (Arctic White)
	2000002076	Kit - Pushbar (Front/Side) TL (Midnight Black)	Kit: Barra de empuje (Delantera y lateral) TL (Midnight Black)	Trousse - Poussoir (frontal/latéral) TL (Midnight Black)
	98734C	Kit - Pushbar (Front/Side) TL (Standard Gray)	Kit: Barra de empuje (Delantera y lateral) TL (Standard Gray)	Trousse - Poussoir (frontal/latéral) TL (Standard Gray)
13	2000002079	Kit - Pushbar (Front Only) (Arctic White)	Kit: Barra de empuje (Solo delantera) (Arctic White)	Trousse - Poussoir (frontal seulement) (Arctic White)
	2000002078	Kit - Pushbar (Front Only) (Midnight Black)	Kit: Barra de empuje (Solo delantera) (Midnight Black)	Trousse - Poussoir (frontal seulement) (Midnight Black)
	1000001600	Kit - Pushbar (Front Only) (Standard Gray)	Kit: Barra de empuje (Solo delantera) (Standard Gray)	Trousse - Poussoir (frontal seulement) (Standard Gray)
14	35980C	Power Cord Non-Refrigerated	Kit: Cable eléctrico L/R	Cordon d'alimentation L/R
15	1000004568	Power Cord - EZTL8	Cable Eléctrico EZTL8	Cordon d'alimentation EZTL8
16	98775C	Kit - Fan Motor/Blade/Screws/Nut	Kit: Motor del ventilador, aspa, tornillos y tuerca	Trousse - Moteur de ventilateur/pales/vis/écrou
17	98776C	Kit - Condenser/Drier/WireTies	Kit: Condensador/secador/lazos de alambre	Trousse - Statiques/sécheur/Colliers
18	98777C	Kit - Compr Mtg Hdwe/Grommets/ Clips/Studs	Kit: Piezas metálicas de montaje del compresor, arandelas, sujetadores y remaches	Trousse - Visserie fix. compr./œillets/clips/goujons
19	98778C	Kit - Heatx/Drier	Kit: Intercambiador de calor y secador	Trousse - Échangeur chaleur/déshydrateur
20	98898C	Kit - Hardware	Kit: Piezas metálicas	Trousse - Visserie
21	0000000238	Kit - 115V Electricals (Relay, Ovrd, Cover)	Kit: Eléctrico, relé, sobrecarga y cubierta	Trousse - Élect./relais/antisurcharge/capot
22	98724C	Kit - Evap. Replacement	Kit: Repuesto evaporador	Trousse - Évaporateur de rechange
23	1000001602	Kit - 75583C Elbow 5/16" x 1/4" (3 Pack)	Kit: 75583C Codo 5/16" x 1/4" (Paquete de 3)	Trousse - 75583C Coude 5/16 po x 1/4 po (paq. 3)
24	1000004547	Harness - Cooler	Arnés - Enfriador	Harnais - Glacière
25	1000004550	Wire - 6" Jumper	Cable - Puente de 6"	Fil - Cavalier de 6"
26	1000004559	Wire Assy - Jumper	Asamblea de alambre - Puente	Assemblage de fils - Cavalier
27	1000004447	Wasteline Drain Assy	Conjunto de tubería de desagüe BF	Écoulement conduite eau usée BF
28A	98900C	Kit - Drain Replace TL	Kit: Repuesto de desagüe TL	Trousse - Écoulement de rechange TL
28B	97969C	Kit - Drain Replace (TL) LR	Kit: Repuesto de desagüe (TL) LR	Trousse - Écoulement de rechange (TL) LR
29	1000001812	Kit - Bottle Filler Drain	Kit: Desagüe de la llenadora de botellas	Trousse - Écoulement remplisseuse de bouteille
30	98773C	Kit - Cold Control	Kit - Control de frío	Kit - Contrôle du Froid
NS	2000002082	Kit - Drop Down Wrapper Stainless TL (Arctic White)	Kit - Panel: (Recubrimiento) acero inoxidable TL (Arctic White)	Trousse - Panneau (Enveloppe) Acier inoxydable TL (Arctic White)
	2000002081	Kit - Drop Down Wrapper Stainless TL (Midnight Black)	Kit - Panel: (Recubrimiento) acero inoxidable TL (Midnight Black)	Trousse - Panneau (Enveloppe) Acier inoxydable TL (Midnight Black)
	2000001267	Kit - Drop Down Wrapper Stainless TL	Kit - Panel: (Recubrimiento) acero inoxidable TL	Trousse - Panneau (Enveloppe) Acier inoxydable TL
NS	2000002085	Kit - Drop Down Wrapper Stainless LZTLD (Arctic White)	Kit - Panel: (Revestimiento): Acero inoxidable LZTLD (Arctic White)	Trousse - Panneau (Enveloppe) Acier inoxydable LZTLD (Arctic White)
	2000002084	Kit - Drop Down Wrapper Stainless LZTLD (Midnight Black)	Kit - Panel: (Revestimiento): Acero inoxidable LZTLD (Midnight Black)	Trousse - Panneau (Enveloppe) Acier inoxydable LZTLD (Midnight Black)
	2000001274	Kit - Drop Down Wrapper Stainless LZTLD	Kit - Panel: (Revestimiento): Acero inoxidable LZTLD	Trousse - Panneau (Enveloppe) Acier inoxydable LZTLD
NS	2000002199	Filler - Wrapper AW LZTLD (Arctic White)	Llenadora: Revestimiento AW LZTLD (Arctic White)	Remplisseuse - Enveloppe LZTLD (Arctic White)
	2000002198	Filler - Wrapper MB LZTLD (Midnight Black)	Llenadora: Revestimiento MB LZTLD (Midnight Black)	Remplisseuse - Enveloppe LZTLD (Midnight Black)
	28025C	Filler - Wrapper Stainless LZTLD	Llenadora: Revestimiento acero inoxidable LZTLD	Remplisseuse - Enveloppe inox LZTLD
NS	1000001893	Panel - Universal Trim Stainless LZTLD	Panel: Banda universal acero inoxidable LZTLD	Panneau - Garniture universelle inox LZTLD
NS	VERSATILE-BFKIT	Kit - Versatile BF Basin	Kit - de lavabo BF versátil	Trousse - de lavabo polyvalent BF

NS = Not Shown  
NS = No se muestra  
NS = Non représenté

**\*INCLUDES RELAY & OVERLOAD. IF UNDER WARRANTY, REPLACE WITH SAME COMPRESSOR USED IN ORIGINAL ASSEMBLY.**

**NOTE:** All correspondence pertaining to any of the above water coolers or orders for repair parts MUST include Model No. and Serial No. of cooler, name and part number of replacement part.

**\*INCLUYE RELÉ Y SOBRECARGA. SI ESTÁ CUBIERTO POR LA GARANTÍA, REEMPLACE CON EL MISMO COMPRESOR QUE SE USA EN EL CONJUNTO ORIGINAL.**

**NOTA:** Toda la correspondencia que guarde relación con los bebedores descritos anteriormente, o los pedidos de piezas de repuesto, DEBEN incluir el n.º de modelo y el n.º de serie del bebedero, nombre y número de pieza del repuesto.

**\*COMPREND RELAIS ET LIMITEUR DE SURCHARGE. SI SOUS GARANTIE, REMPLACÉ PAR LE MÊME COMPRESSEUR QUE CELUI DE L'APPAREIL D'ORIGINE.**

**REMARQUE :** Toute correspondance concernant toute fontaine à eau fraîche ci-dessus ou toute commande de pièces détachées devra IMPÉRATIVEMENT inclure le numéro de modèle et le numéro de série de l'appareil, ainsi que le nom et le numéro de pièce des pièces de rechange.

**BOTTLE FILLER REPLACEMENT PART KITS**  
**KITS DE PIEZAS DE REPUESTO DE LA LLENADORA DE BOTELLAS**  
**TROUSSES DE PIÈCES DE RECHANGE POUR LA REMPLISSEUSE DE BOUTEILLE**  
**LZSTL8WSAP, LZSTL8WSAP-PF, LZSTL8WSMP, LZS8TLWSMP-PF, LZS8TLWSSP-PF**

ITEM NO.	PART NO.	DESCRIPTION	DESCRIPCIÓN	DESCRIPTION
NS	98546C	Kit - Aerator Replacement	Kit - Repuesto de aireador	Trousse - Aérateur de rechange
31	98549C	Kit - Hardware & Waterway (BF)	Kit - Piezas metálicas y canales (LIB)	Trousse - Visserie et circuit d'eau (RB)
32	1000004573	Kit - Solenoid Valve 120V (BF)	Kit - Conjunto de válvula solenoide	Trousse - Assemblage électrovanne
NS	2000002090	Nameplate - Elkay Filtered (AW)	Placa de identificación: Elkay con filtro (AW)	Plaque signalétique - Elkay à filtre (AW)
	2000002091	Nameplate - Elkay Filtered (MB)	Placa de identificación: Elkay con filtro (MB)	Plaque signalétique - Elkay à filtre (MB)
	2000002088	Nameplate - Elkay Filtered (SG)	Placa de identificación: Elkay con filtro (SG)	Plaque signalétique - Elkay à filtre (SG)
33	2000002072	Kit - Top Cover Assy (BF) (AW)	Kit - Conjunto de cubierta superior (LIB) (AW)	Trousse - Capot supérieur (RB) (AW)
	2000002071	Kit - Top Cover Assy (BF) (MB)	Kit - Conjunto de cubierta superior (LIB) (MB)	Trousse - Capot supérieur (RB) (MB)
	1000002433	Kit - Top Cover Assy (BF) (SG)	Kit - Conjunto de cubierta superior (LIB) (SG)	Trousse - Capot supérieur (RB) (SG)
34	1000005219	Kit - IR Sensor K+	Kit - Sensor infrarrojo	Trousse - Capteur IR
35	2000001906	Kit - Connected Ready LED Board (BBB/R)	Kit - Tablero LED listo para conectar (BBB/R)	Trousse - Carte LED prête à être connectée (BBB/R)
NS	1000004436	Kit - Tower/Basin Gasket	Kit - Torre y empaquetadura de la tarja	Trousse - Joint tour/fontaine
36	1000004546	Harness - Bottle Filler	Arnés - Llenadora de botellas	Harnais - Remplisseur De Bouteille
37	1000004549	Harness - LED/IR Board	Arnés - Tablero LED/IR	Harnais - Carte LED/IR

NS = Not Shown

**FCC COMPLIANCE STATEMENT**

CAUTION: Changes or modifications not expressly approved could void your authority to use this equipment

This device complies with Part 15 of the FCC Rules. Operation to the following two conditions: (1) This device may not cause harmful interference, and (2) this device must accept any interference received, including interference that may cause undesired operation

**INDUSTRY CANADA STATEMENT**

This device complies with Industry Canada license-exempt RSS standard(s). Operation is subject to the following two conditions: (1) this device may not cause interference, and (2) this device must accept any interference, including interference that may cause undesired operation of the device.

Le présent appareil est conforme aux CNR d'Industrie Canada applicables aux appareils radio exempts de licence. L'exploitation est autorisée aux deux conditions suivantes : (1) l'appareil ne doit pas produire de brouillage, et (2) l'utilisateur de l'appareil doit accepter tout brouillage radioélectrique subi, même si le brouillage est susceptible d'en compromettre le fonctionnement.



**2000002208**

**FOR PARTS, CONTACT YOUR LOCAL DISTRIBUTOR OR CALL 1.800.834.4816**  
PARA PIEZAS, CONTACTE A SU DISTRIBUIDOR LOCAL O LLAME AL 1.800.834.4816  
POUR OBTENIR DES PIÈCES, CONTACTEZ VOTRE DISTRIBUTEUR LOCAL OU COMPOSEZ LE 1.800.834.4816

**REPAIR SERVICE INFORMATION TOLL FREE NUMBER 1.800.260.6640**  
NÚMERO GRATIS DE SERVICIO 1.800.260.6640  
INFORMATIONS POUR LE SERVICE PAR NUMERO SANS FRAIS 1.800.260.6640

PRINTED IN U.S.A.  
IMPRESO EN LOS E.E.U.U.  
IMPRIME AUX E.-U.

**ELKAY MANUFACTURING Co. • 1333 BUTTERFIELD ROAD SUITE 200 DOWNERS GROVE, IL 60515 USA - • 630.574.8484 • www.elkay.com**