

### PRODUCT SPECIFICATIONS

Mounting Frame for Bi-level In-wall Refrigerated Coolers. Overall dimensions are 37-1/2" x 12" x 37-3/4". Made of Galvanized Steel.

<b>Mounting Type:</b>	Wall Mount (Inwall Frame/Plate)
<b>Material:</b>	Galvanized Steel
<b>Finish:</b>	Galvanized Steel
<b>Dimensions:</b>	37-1/2" x 12" x 37-3/4"
<b>Shipping Weight:</b>	32 lbs.

**Special Note:** For use with Elkay ENOB, ERFP, ERO, ERPB, LNTE, LRPB refrigerated bi-level models.

- Two-station mounting frame enables installation of in-wall drinking water models
- Compatible with various Elkay<sup>®</sup> refrigerated models; see specifications tab for details
- Mounting frame included with specific SwirlFlo<sup>®</sup> and Soft Sides<sup>®</sup> models
- Secures directly to a variety of load-bearing surfaces
- Refer to end product for ADA compliance information
- Built in the USA



#### Included with Product: Mounting Frame Assembly

A Century of Tradition and Quality.

For more than 100 years, Elkay has been making innovative products and providing exceptional customer care. We take pride in offering plumbing products that make life easier, inspire change and leave the world a better place.



[Installation Instructions \(PDF\) - 97153C](#)

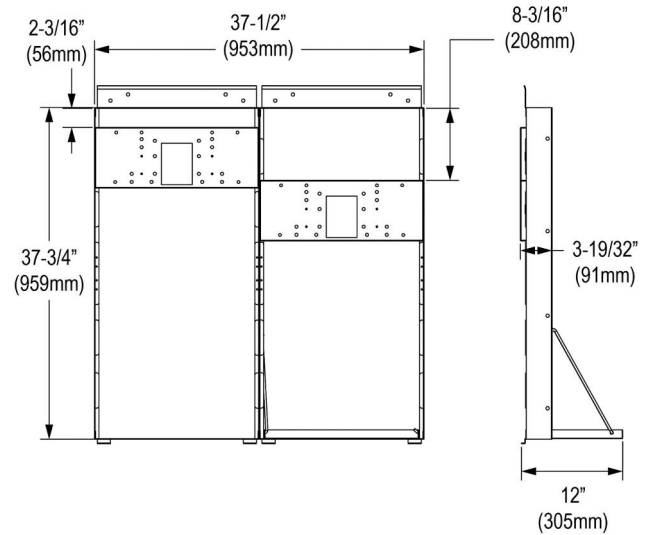

PART: \_\_\_\_\_ QTY: \_\_\_\_\_

PROJECT: \_\_\_\_\_

CONTACT: \_\_\_\_\_

DATE: \_\_\_\_\_

NOTES: \_\_\_\_\_

APPROVAL: \_\_\_\_\_

*In keeping with our policy of continuing product improvement, Elkay reserves the right to change product specifications without notice. Please visit [elkay.com](http://elkay.com) for the most current version of Elkay product specification sheets. This specification describes an Elkay product with design, quality, and functional benefits to the user. When making a comparison of other producers' offerings, be certain these features are not overlooked.*

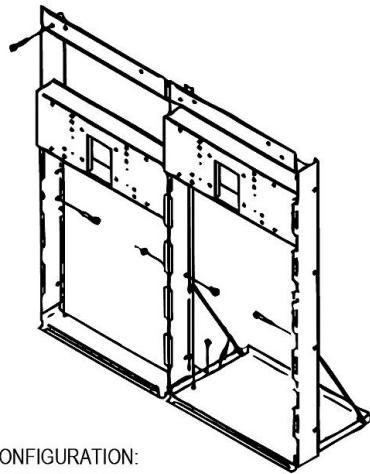

REVERSED CONFIGURATION:  
HIGHER UNIT ON THE RIGHT

MAKE SURE FRAME CONFIGURATION MATCHES  
THE COOLER TO BE INSTALLED

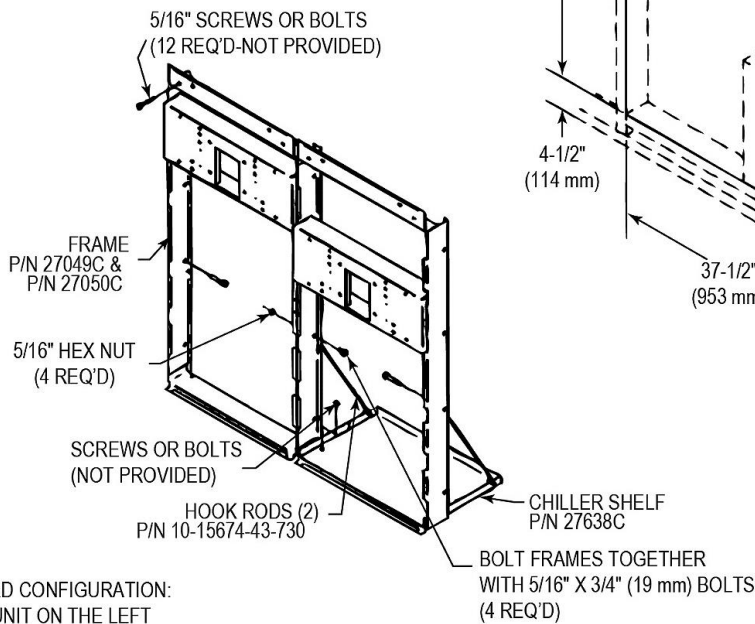

STANDARD CONFIGURATION:  
HIGHER UNIT ON THE LEFT

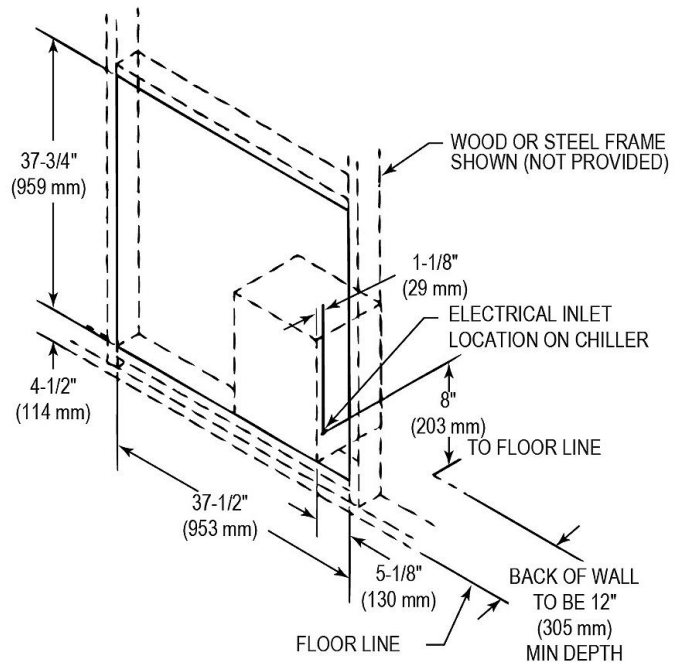

In keeping with our policy of continuing product improvement, Elkay reserves the right to change product specifications without notice. Please visit [elkay.com](http://elkay.com) for the most current version of Elkay product specification sheets. This specification describes an Elkay product with design, quality, and functional benefits to the user. When making a comparison of other producers' offerings, be certain these features are not overlooked.