

PRODUCT SPECIFICATIONS

Mounting Frame for Single-station In-wall Refrigerated Bottle Filling Stations. Overall dimensions are 18-3/4" x 12" x 40". Made of Galvanized Steel.

Mounting Type:	Wall Mount (Inwall Frame/Plate)
Material:	Galvanized Steel
Finish:	Galvanized Steel
Dimensions:	18-3/4" x 12" x 40"
Shipping Weight:	15 lbs.

Special Note: For use with single-station in-wall refrigerated bottle filling stations.

- Single-station mounting frame enables installation of in-wall drinking water models
- Compatible with various refrigerated models
- Mounting frame included with specific models
- Secures directly to a variety of load-bearing surfaces
- Refer to end product for ADA compliance information
- Built in the USA

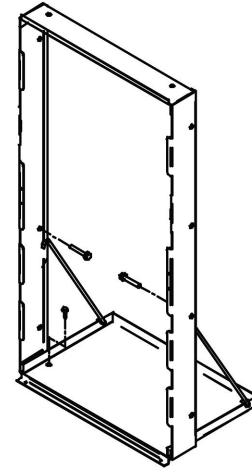

Included with Product: Mounting Frame Assembly

A Century of Tradition and Quality.

For more than 100 years, Elkay has been making innovative products and providing exceptional customer care. We take pride in offering plumbing products that make life easier, inspire change and leave the world a better place.



[Installation Instructions \(PDF\) - 98560C](#)
[Warranty \(PDF\)](#)

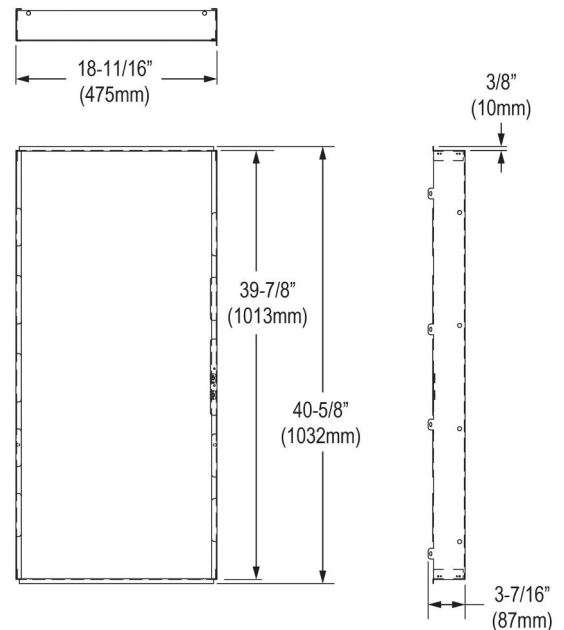

PART: _____ QTY: _____

PROJECT: _____

CONTACT: _____

DATE: _____

NOTES: _____

APPROVAL: _____

In keeping with our policy of continuing product improvement, Elkay reserves the right to change product specifications without notice. Please visit elkay.com for the most current version of Elkay product specification sheets. This specification describes an Elkay product with design, quality, and functional benefits to the user. When making a comparison of other producers' offerings, be certain these features are not overlooked.

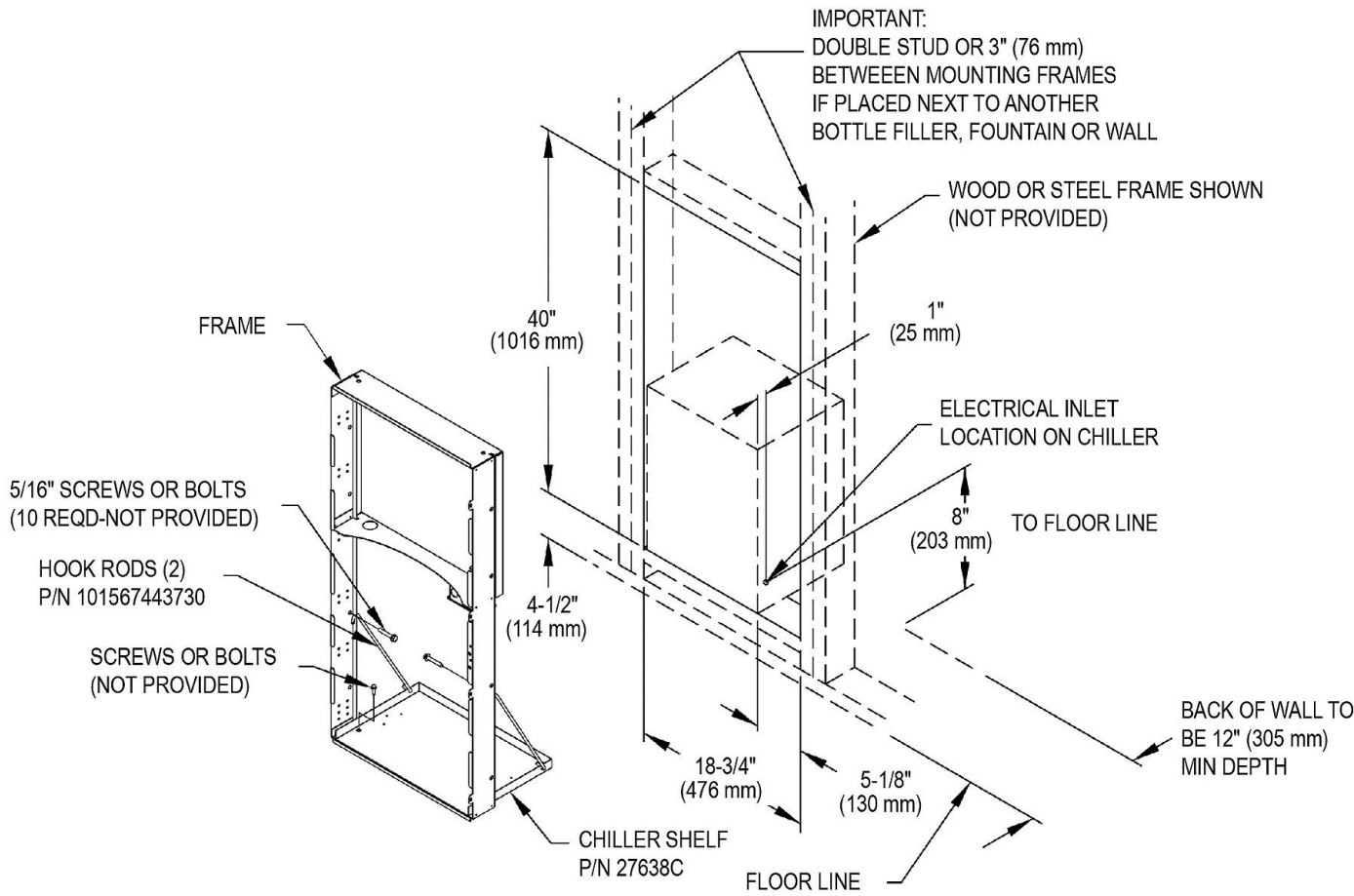

In keeping with our policy of continuing product improvement, Elkay reserves the right to change product specifications without notice. Please visit elkay.com for the most current version of Elkay product specification sheets. This specification describes an Elkay product with design, quality, and functional benefits to the user. When making a comparison of other producers' offerings, be certain these features are not overlooked.