

SPECIFICATIONS

PRODUCT SPECIFICATIONS

In-wall Mounting Plate for Single-station OVL Non-refrigerated Fountains. Made of Galvanized Steel.

Material:	Galvanized Steel
Finish:	Black (BK)
Shipping Weight:	11 lbs.

Special Note: For use with Halsey Taylor OVL-II single fountain models.

- Single-station surface mounting plate provides additional support for on-wall drinking water model installations
- Compatible with specific Halsey Taylor® non-refrigerated models; see specifications tab for details
- Plate can be installed directly to studs or in conjunction with ML100 mounting legs (optional accessory sold separately)
- Constructed of heavy-gauge steel supporting up to 500 lbs
- Adjustable height setting allows for adult or child installation
- Built in the USA

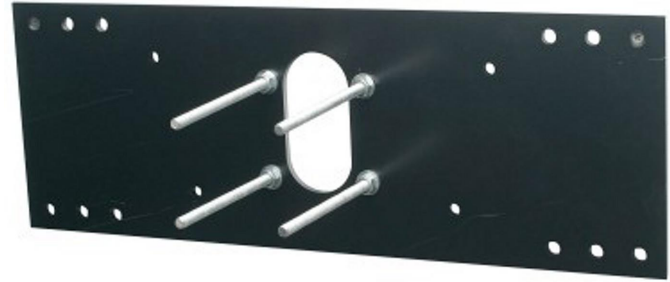

Included with Product: Mounting Frame Assembly

A Century of Tradition and Quality.

For more than 100 years, Elkay has been making innovative products and providing exceptional customer care. We take pride in offering plumbing products that make life easier, inspire change and leave the world a better place.

[Installation Instructions \(PDF\) - 98371C](#)

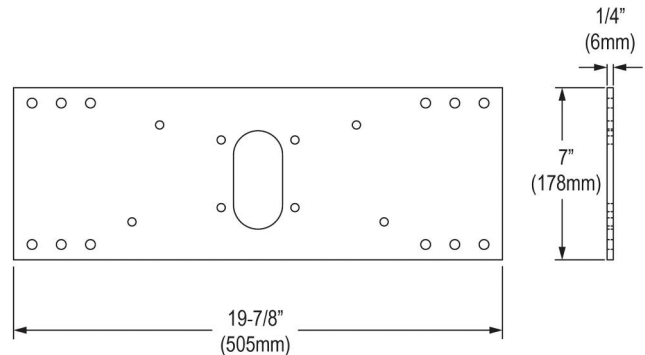

PART: _____ QTY: _____

PROJECT: _____

CONTACT: _____

DATE: _____

NOTES: _____

APPROVAL: _____

In keeping with our policy of continuing product improvement, Elkay reserves the right to change product specifications without notice. Please visit elkay.com for the most current version of Elkay product specification sheets. This specification describes an Elkay product with design, quality, and functional benefits to the user. When making a comparison of other producers' offerings, be certain these features are not overlooked.

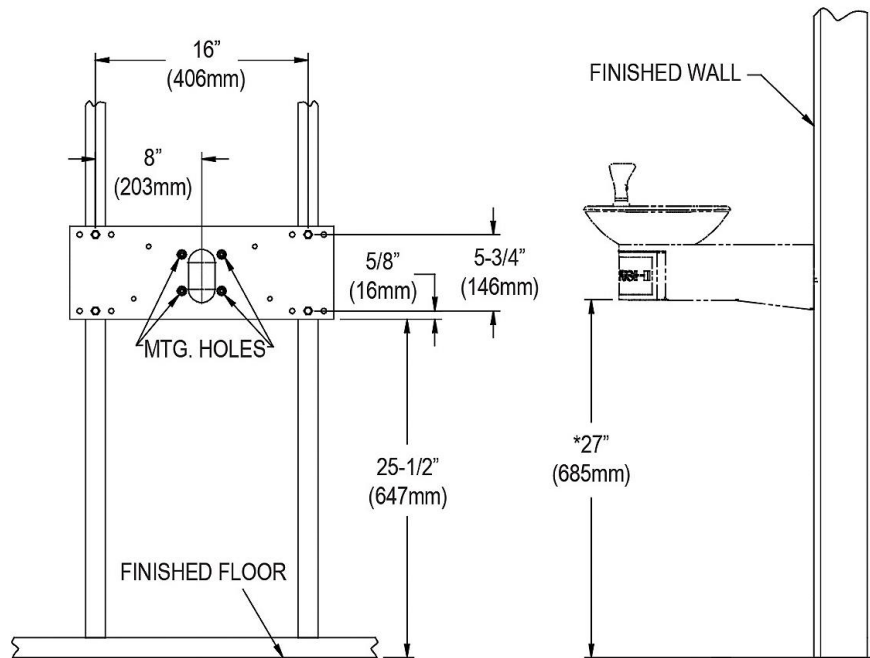
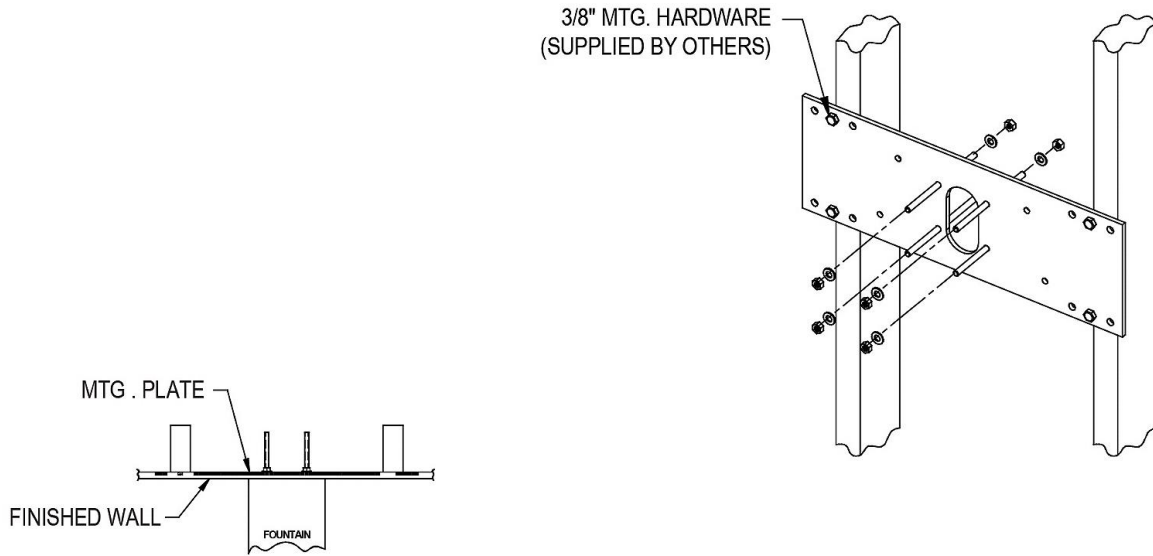

* ADA REQUIREMENT – REDUCE HEIGHT BY 3" FOR INSTALLATION OF CHILDRENS ADA COOLER.
WITH STANDARD STUD LENGTH OF 6 INCHES
NOTE: – AFTER INSTALLATION, U-BOLTS AND THREADED RODS MAY NEED TO BE TRIMMED.

In keeping with our policy of continuing product improvement, Elkay reserves the right to change product specifications without notice. Please visit elkay.com for the most current version of Elkay product specification sheets. This specification describes an Elkay product with design, quality, and functional benefits to the user. When making a comparison of other producers' offerings, be certain these features are not overlooked.