

PRODUCT SPECIFICATIONS

In-wall Mounting Plate for Bi-level On-wall White Granite Composite Fountain. Overall dimensions are 35-7/8" x 1/4" x 12". Made of Galvanized Steel.

Material:	Galvanized Steel
Finish:	Black (BK)
Dimensions:	35-7/8" x 1/4" x 12"
Shipping Weight:	33 lbs.

Special Note: For use with two station white granite composite fountains.

- Universal design provides extra support when mounting on-wall two-station models
- Plate can be installed directly to studs or in conjunction with ML100 mounting legs (optional accessory sold separately)
- Constructed of heavy-gauge steel supporting up to 500 lbs
- Secures directly to a variety of load-bearing surfaces
- Adjustable height setting allows for adult or child ADA installation
- Built in the USA



Included with Product: Mounting Plate

A Century of Tradition and Quality. For more than 100 years, Elkay has been making innovative products and providing exceptional customer care. We take pride in offering plumbing products that make life easier, inspire change and leave the world a better place.

[Installation Instructions \(PDF\) - 98374C](#)

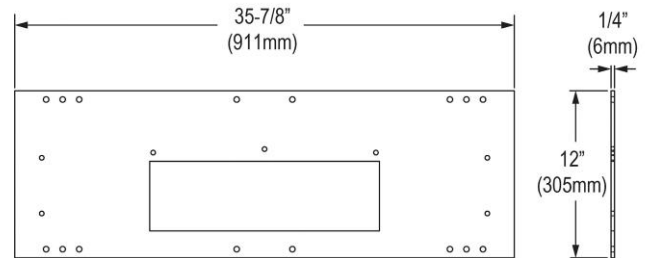

PART: _____ QTY: _____

PROJECT: _____

CONTACT: _____

DATE: _____

NOTES: _____

APPROVAL: _____

In keeping with our policy of continuing product improvement, Elkay reserves the right to change product specifications without notice. Please visit elkay.com for the most current version of Elkay product specification sheets. This specification describes an Elkay product with design, quality, and functional benefits to the user. When making a comparison of other producers' offerings, be certain these features are not overlooked.

.50 (13 mm) X .75 (19) ROUND (4)

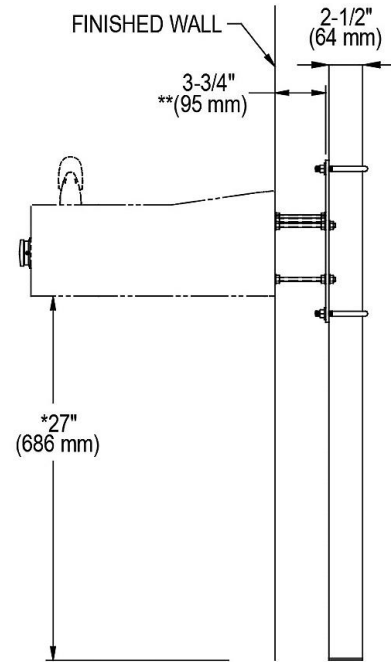
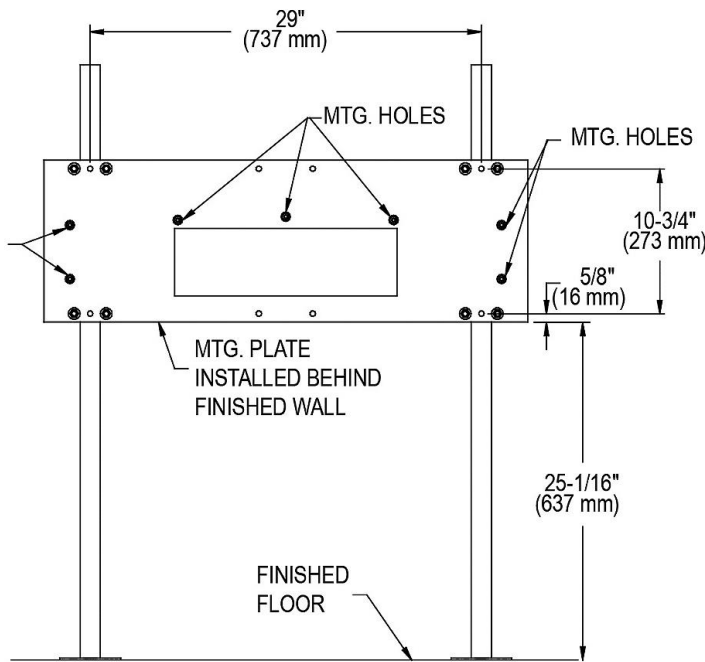
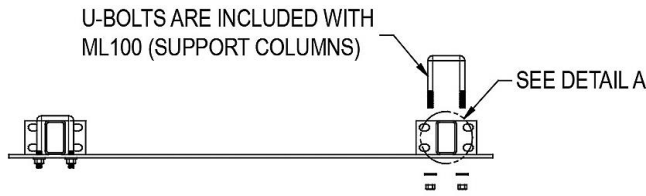
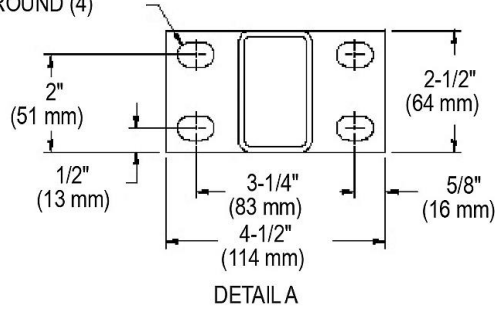

* ADA REQUIREMENT

** WITH STANDARD STUD LENGTH OF 6 INCHES.

NOTE - AFTER INSTALLATION, U-BOLTS AND THREADED RODS MAY NEED TO BE TRIMMED

In keeping with our policy of continuing product improvement, Elkay reserves the right to change product specifications without notice. Please visit elkay.com for the most current version of Elkay product specification sheets. This specification describes an Elkay product with design, quality, and functional benefits to the user. When making a comparison of other producers' offerings, be certain these features are not overlooked.