

HAND BLOWN ETCHED GLASS SHADE

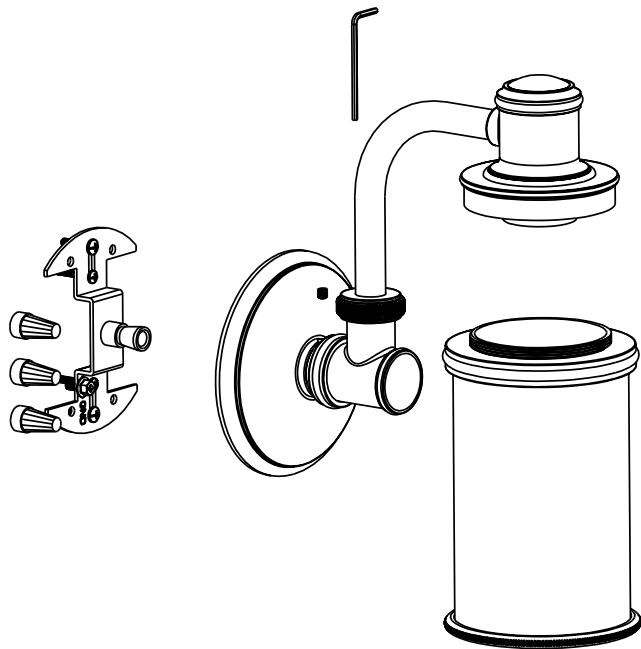

INSTALLATION NOTES: THIS LIGHT MOUNTS ONTO A STANDARD OUTLET BOX.

FINISHES: 10B- OIL RUBBED BRONZE, 14- POLISHED NICKEL, 15- SATIN NICKEL, 26 POLISHED CHROME		UNIT: INCH [MM]	GINGER
MATERIAL: VARIOUS BRASSES, PLATED STEEL HDRW, HAND BLOWN GLASS		WEIGHT: 3 LBS. 8 OZ. [1.6 KG]	
PART NO.	4581	SINGLE LIGHT	
DATE: 11.27.07	REV. DATE:	SCALE 1:4	COLUMNAR
			DWG. NO. PD-4581