

hangrohe

- EN** Installation / User Instructions / Warranty
- FR** Instructions de montage / Mode d'emploi / Garantie
- ES** Instrucciones de montaje / Manejo / Garantía

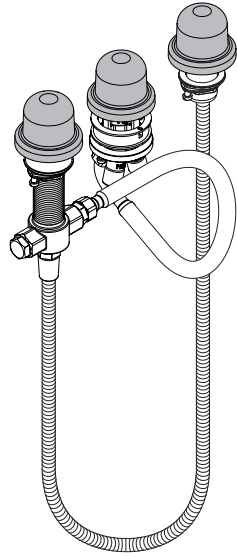

**Rough for 3-hole Single Control Bath
Mixer**
13439181

English

Safety Notes

- ⚠ **WARNING: To avoid the risk of product failure, property damage, and personal injury, do the following:**
- ⚠ This product should be installed by a licensed professional plumber.
- ⚠ This product is for use with drinking water only.
- ⚠ **Failure to follow these instructions may result in product failure and property damage, and may void the warranty.**

Technical Information

Water pressure	
Recommended	15 - 75 PSI (0.1 - 0.5 MPa)
Maximum	145 PSI (1 MPa)
Hot water temp.	
Recommended	120° - 140° F (48° - 60° C)*
Maximum	158°F (70° C)*
Hole size in mounting surface	
spout	1 3/8" (35 mm)
valve	2" (50 mm)
handshower	1 3/8" (35 mm)
Max. depth of mounting surface	1 5/8" (40 mm)

* Please know and follow all applicable local plumbing codes when setting the temperature on the water heater.

Installation Considerations

- Read over these instructions thoroughly before beginning installation. Make sure that you have all tools and supplies needed to complete the installation.
- ⚠ **This unit includes a cutout template, which must be used. Custom installations may require additional parts which cannot be furnished by Hansgrohe.**
- This unit is not anti-scald. In Massachusetts, or if required by local plumbing code, install an approved water temperature limiting device conforming to ASSE 1070 (not available from Hansgrohe).
- This faucet requires 1/2" hot and cold supply lines (not included).
- This unit must be completed with a trim kit. The handshower must be installed.
- Protection against back siphonage is provided by a check valve (included with the trim kit) and by an automatically resetting diverter (included with the trim kit).
- To insure proper fit of the trim, the surface material (tile, etc) must be installed prior to installation of this rough.
- To prevent scald injury, the maximum output temperature of the shower mixing valve (not included) must be no higher than 120°F. In Massachusetts, the maximum output temperature can be no higher than 112°F.
- Keep this booklet and the receipt (or other proof of date and place of purchase) for this product in a safe place. The receipt is required should it be necessary to request warranty parts.

Français

Consignes de Sécurité

- ⚠ **AVERTISSEMENT : Afin d'éviter les risques de défaillance du produit, de dommages matériels et de blessures corporelles, veuillez procéder de la manière suivante :**
- ⚠ Ce produit devrait être installé par un plombier professionnel certifié.
- ⚠ Ce produit doit être utilisé avec de l'eau potable seulement.
- ⚠ **Le non-respect de ces instructions peut entraîner une défaillance du produit et des dommages matériels, ainsi que l'annulation de la garantie.**

Données techniques

Pression d'eau recommandée	15 - 75 PSI (0.1 - 0.5 MPa)
maximum	145 PSI (1 MPa)
Température d'eau chaude recommandée	120°-140° F (48° - 60° C)*
maximum	158°F (70° C)*
Dimension du trou dans la surface de montage	
bec	1 3/8 po (35 mm)
robinets	2 po (50 mm)
douchette	1 3/8 po (35 mm)
Profondeur maximale de la surface de montage	1 3/8 po (40 mm)

* Vous devez connaître et respecter tous les codes de plomberie locaux applicables pour le réglage de la température du chauffe-eau.

À prendre en considération pour l'installation

- Veuillez lire toutes ces instructions avant de procéder à l'installation. Assurez-vous de disposer de tous les outils et du matériel nécessaires pour l'installation.
- ⚠ **Ce produit comprend un gabarit à découper que vous devez utiliser. Les installations sur mesure peuvent nécessiter des pièces supplémentaires qui ne sont pas fournies par Hansgrohe.**
- Ce produit ne possède pas de dispositif anti-brûlure. Au Massachusetts, ou si le code de plomberie local l'exige, ce produit doit être utilisé avec un dispositif de limitation de température pour l'eau chaude approuvé et conforme à la norme ASSE 1070.
- Ce robinet requiert des conduites d'alimentation d'eau chaude et d'eau froide de 1/2 po (non comprises).
- Ce produit doit être complété par un jeu de robinets. La douchette doit être installée.
- La protection contre le refoulement d'eau est assurée par un clapet de non-retour (compris avec le jeu de robinets) et un dispositif de dérivation à réenclenchement automatique (compris avec le jeu de robinets).
- Pour assurer l'ajustement convenable du robinet, les matériaux de surface (carreaux, etc.) doivent être installés avant cette pièce.
- Pour empêcher des blessures par ébullition, la température de sortie maximale du robinet de douche ne doit pas excéder 120°F. Au Massachusetts, la température de sortie maximale du robinet de douche ne doit pas excéder 112°F.
- Conservez ce livret et le reçu (ou une autre preuve sur laquelle figurent la date et l'endroit de l'achat) pour ce produit dans un endroit sûr. Le reçu est requis si vous commandez des pièces sous garantie.

Indicaciones de seguridad

- ⚠ **ADVERTENCIA: Para evitar el riesgo de falla del producto, daño a la propiedad y lesiones personales, haga lo siguiente:**
- ⚠ Este producto debe ser instalado por un plomero profesional matriculado.
- ⚠ Este producto ha sido creado para su uso exclusivo con agua potable.
- ⚠ **No seguir estas instrucciones puede resultar en la falla del producto y daño de la propiedad, y puede anular la garantía.**

Datos técnicos

Presión en servicio recomendada	15 - 75 PSI (0.1 - 0.5 MPa)
max.	145 PSI (1 MPa)
Temperatura del agua caliente recomendada	120°-140° F (48° - 60° C)*
max.	158° F (70° C)*
Tamaño del orificio en la superficie de montaje	
caño	1 ³ / ₈ " (35 mm)
válvulas	1 ¹ / ₄ " (50 mm)
teleducha	1 ³ / ₈ " (35 mm)
Profundidad máxima de la superficie de montaje	1 ⁵ / ₈ " (40 mm)

- * Debe conocer y cumplir todos los códigos locales aplicables para ajustar la temperatura del calentador de agua.

Consideraciones para la instalación

- Antes de comenzar la instalación, lea estas instrucciones detenidamente. Asegúrese de tener las herramientas y los insumos necesarios para completar la instalación.
- ⚠ **Esta unidad incluye una plantilla de corte que debe utilizarse. Las instalaciones personalizadas pueden requerir piezas adicionales que pueden no ser provistas por Hansgrohe.**
- Esta unidad no es anti-escaldadura. En Massachusetts, o según lo requiera el código de plomería local, este producto debe ser utilizado con un dispositivo de limitación de temperatura para agua caliente aprobado y cumpla la norma ASSE 1070.
- Este grifo requiere tuberías de suministro de agua caliente y fría de 1/2" (no incluidas).
- Esta unidad debe completarse con un juego de pieza exterior. Se debe instalar la ducha de mano.
- Se proporciona protección contra el efecto de sifón inverso mediante una válvula de retención (incluida con el juego de pieza exterior) y con la reconfiguración automática del distribuidor (incluido en el juego de pieza exterior).
- Para asegurar el ajuste adecuado de la pieza exterior, el material de superficie (azulejo, etc.) debe colocarse antes de la instalación de la pieza interior.
- Para evitar escaldaduras, la máxima temperatura de salida de la válvula de la ducha no debe exceder los 120°F. En Massachusetts, la máxima temperatura de salida de la válvula de la ducha no debe exceder los 112°F.
- Mantenga este folleto y el recibo (u otro comprobante del lugar y fecha de compra) de este producto en lugar seguro. El recibo se requiere en caso de ser necesario solicitar piezas bajo garantía.

Rough for 3-hole Single Control Bath Mixer
13439181

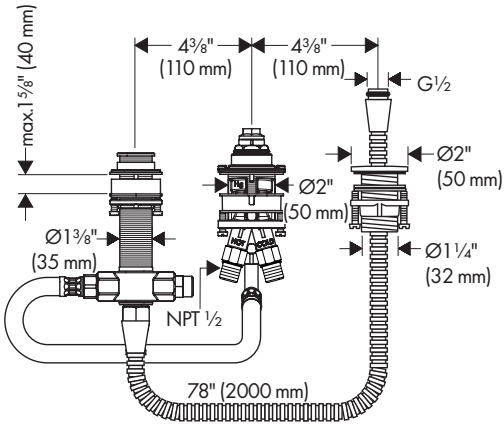

**Tools Required / Outils Utiles /
Herramientas Útiles**

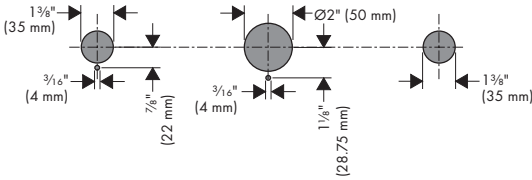
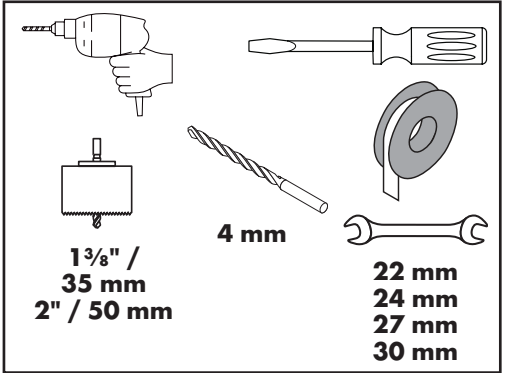

Finish Sets / Sets de finition / Embellecedores exteriores

Metropol
32556XX1 / 74554XX1

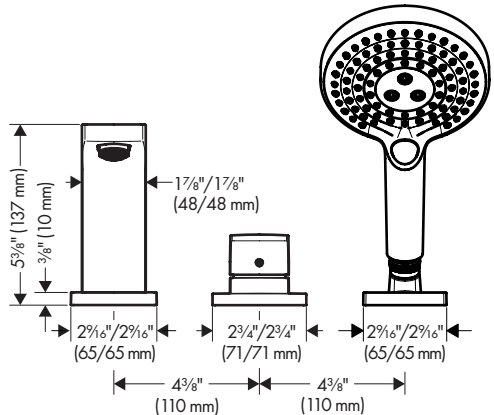
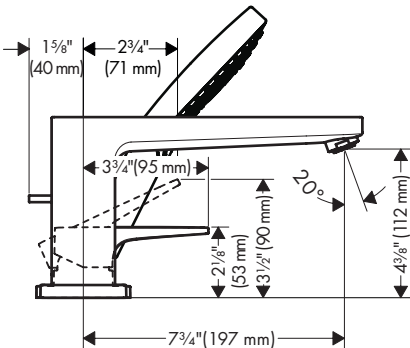

Installation / Installation / Instalación

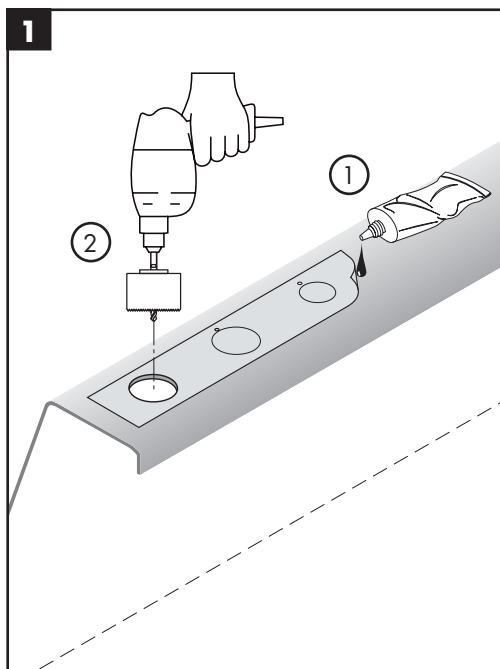

Fasten the template to the mounting surface.

Drill the holes.

Fixez le gabarit à la surface de montage.

Percez les trous.

Ajuste la plantilla a la superficie de montaje.

Perfore los orificios.

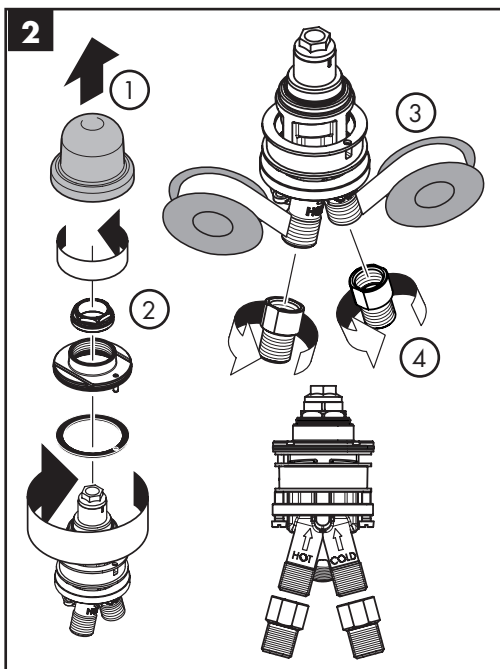

Remove the plaster shield, clamping nut, fastening ring, and sealing ring from the mixing valve.

Wrap the hot and cold inlets on the valve using plumber's tape.

Install the adapters.

Retirez le protecteur, l'écrou de serrage, l'anneau de fixation et l'anneau d'étanchéité du mitigeur.

Enveloppez les filets des orifices d'arrivée d'eau chaude et d'eau froide avec du ruban de plomberie.

Installez les adaptateurs.

Retire el escudo de yeso, la tuerca de ajuste, el aro de ajuste y el aro de sellado de la válvula mezcladora.

Envuelva las roscas de las entradas de agua fría y caliente con cinta de plomería.

Instale los adaptadores.

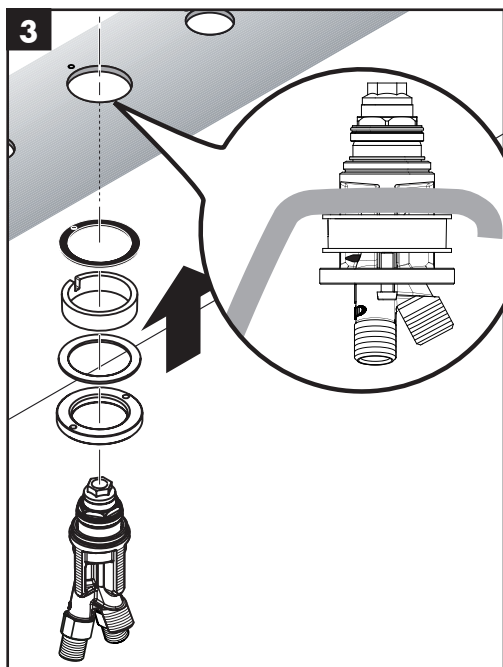

Insert the mixing valve up through the mounting surface.

Insérez le mitigeur dans la surface de montage.

Inserte la válvula mezcladora hacia arriba a través de la superficie de montaje.

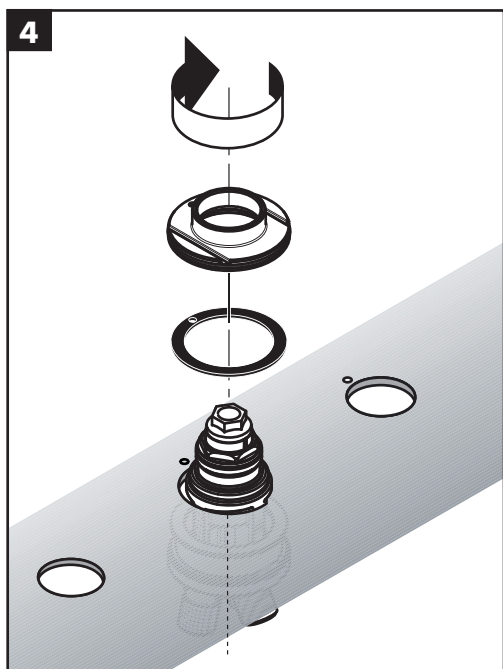

Install the sealing ring and the fastening ring on the mixing valve.

The pin on the fastening must go through the holes in the sealing ring and the mounting surface.

Installez l'anneau d'étanchéité et l'anneau de fixation sur le mitigeur.

La tige sur la fixation doit passer dans les trous de l'anneau d'étanchéité et la surface de montage.

Instale el aro de sellado y el aro de ajuste en la válvula mezcladora.

El pasador de fijación debe atravesar los orificios en el aro de sellado y la superficie de montaje.

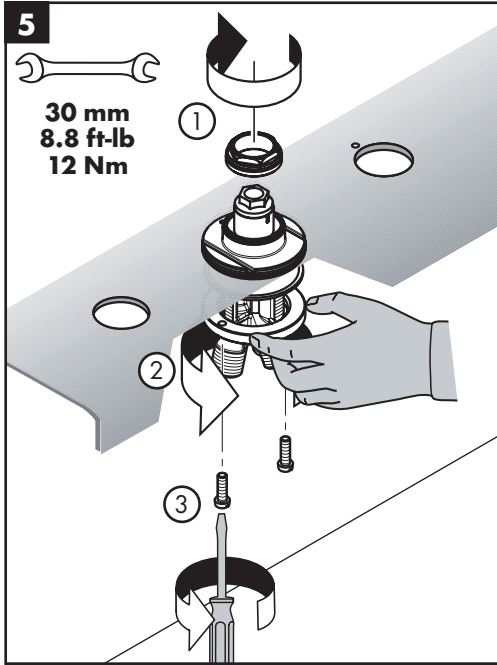

Install the clamping nut on the mixing valve.
From below, tighten the mounting nut by hand.
Tighten the tensioning screws.

Installez l'écrou de serrage sur le mitigeur.
Par le dessous, serrez l'écrou de montage à la main.
Serrez les vis de pression.

Coloque la tuerca de ajuste en la válvula mezcladora.
Desde abajo, ajuste la tuerca de montaje con la mano.
Apriete los tornillos tensores.

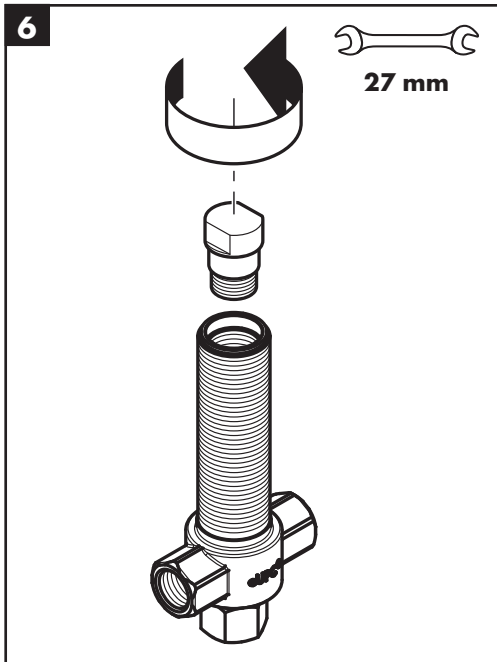

Remove the plug from the spout tee.

Retirez le bouchon du raccord en T du bec de remplissage.

Retire el tapón de la "T" del surtidor.

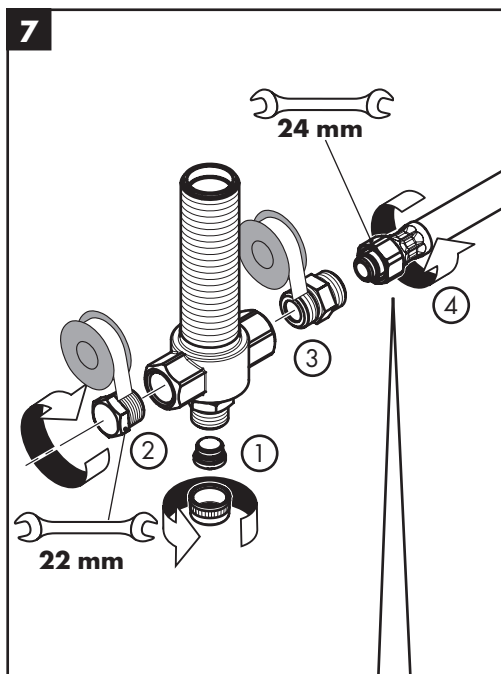
7

Install the sealing plug on the bottom of the tee. Tighten the knurled nut.

Wrap the threads on the plug. Install the plug on one of the side ports of the tee.

Wrap the threads on the hose adapter. Install it on the other side port of the tee.

Install the end of the connection hose on the adapter.

Installez le bouchon d'étanchéité au bas du raccord en T. Serrez l'écrou moleté.

Enroulez les filets sur le bouchon. Installez le bouchon sur l'un des orifices latéraux du raccord en T.

Enroulez les filets sur l'adaptateur de tuyau. Installez-le sur l'autre orifice latéral du raccord en T.

Installez l'extrémité du tuyau de raccordement sur l'adaptateur.

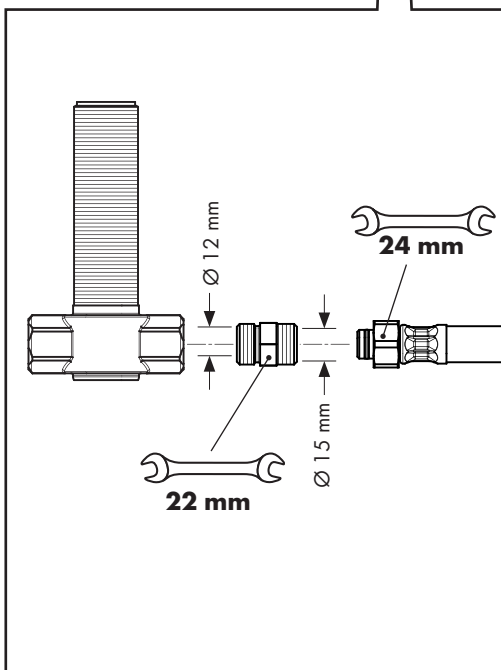

Instale el tapón de sellado en la parte inferior de la "T". Apriete la tuerca moleteada.

Envuelva las roscas en el tapón. Coloque el tapón en uno de los puertos laterales de la "T".

Envuelva las roscas en el adaptador de la manguera. Coloque en el otro puerto lateral de la "T".

Instale el extremo de la manguera de conexión en el adaptador.

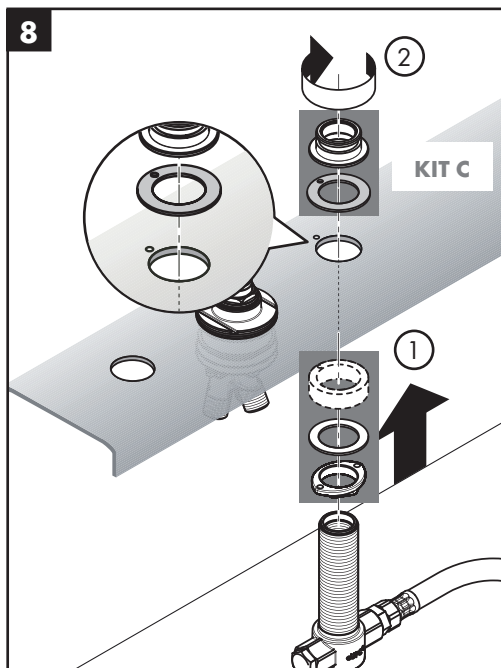
8

Install the mounting nut and washer on the spout tee. If the mounting surface is thin, install the white plastic spacer. Otherwise, the spacer may be discarded.

Push the spout tee up through the mounting surface. Install the sealing ring and spout support.

Rest the spout support on the mounting surface. The pin on the spout support should go through the holes in the sealing ring and in the mounting surface.

Installez l'écrou de montage et la rondelle sur le raccord en T du bec de remplissage. Si la surface de montage est mince, installez la pièce d'espacement en plastique blanc. Sinon, vous pouvez mettre la pièce d'espacement au rebut.

Poussez le raccord en T du bec de remplissage vers le haut, au travers de la surface de montage. Installez l'anneau d'étanchéité et le support du bec de remplissage.

Déposez le support du bec de remplissage sur la surface de montage. La tige sur le support du bec de remplissage doit passer dans les trous de l'anneau d'étanchéité et la surface de montage.

Instale la tuerca de montaje y la arandela en la "T" del surtidor. Si la superficie de montaje es delgada, instale el separador plástico blanco. De lo contrario, el separador puede desecharse.

Empuje la "T" del surtidor hacia arriba a través de la superficie de montaje. Instale el aro de sellado y el soporte del surtidor.

Apoye el soporte del surtidor en la superficie de montaje. El pasador en el soporte del surtidor debe atravesar los orificios en el aro de sellado y la superficie de montaje.

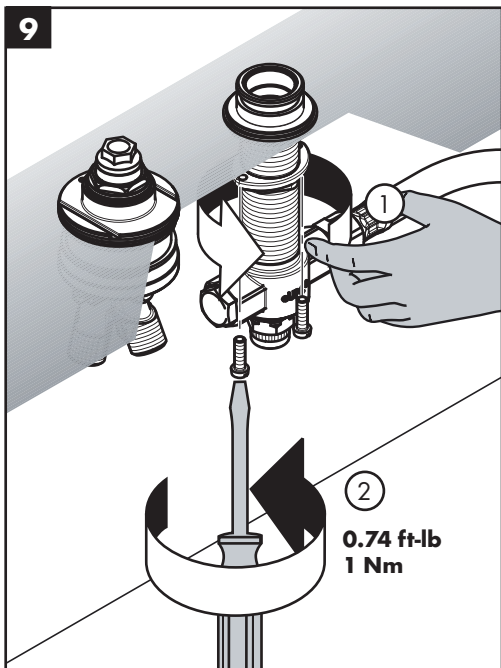

Tighten the mounting nut by hand. Tighten the tensioning screws.

Serrez l'écrou de montage à la main. Serrez les vis de pression.

Apriete la tuerca de montaje con la mano. Apriete los tornillos tensores.

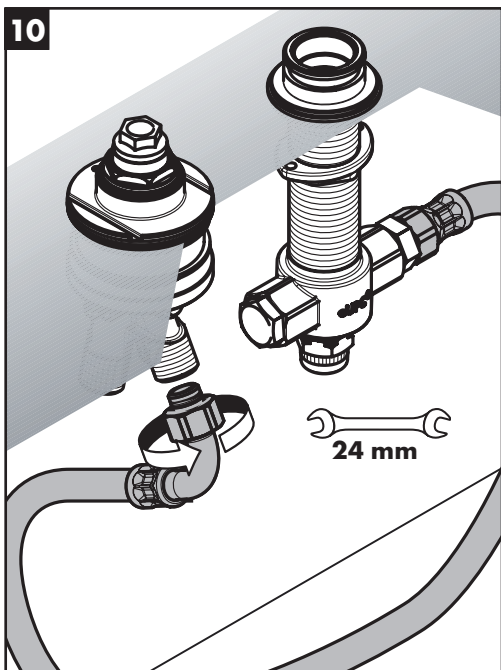

Connect the end of the connection hose to the outlet port on the mixing valve.

Raccordez l'extrémité du tuyau de raccordement à l'orifice de sortie sur le mitigeur.

Conecte el extremo de la manguera de conexión al orificio de salida en la válvula mezcladora.

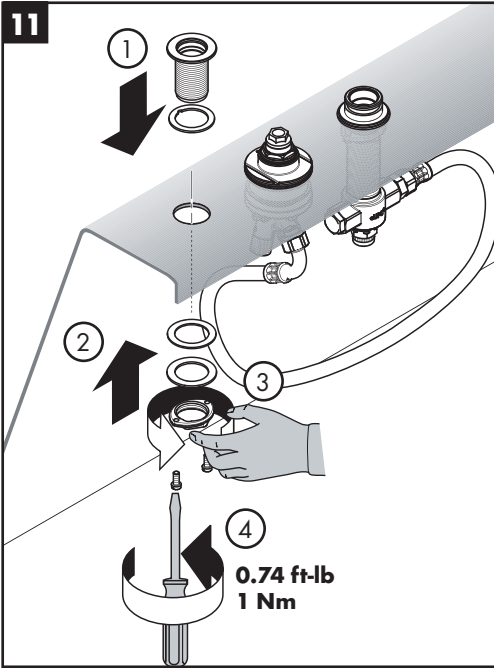
11

Place the handshower holder and sealing ring on the mounting surface.

Install the fiber washer, metal washer, and mounting nut on the handshower holder.

Tighten the mounting nut by hand. Tighten the tensioning screws.

Placez le support de douchette et l'anneau d'étanchéité sur la surface de montage.

Installez la rondelle en fibre, la rondelle métallique et l'écrou de montage sur le support de douchette.

Serrez l'écrou de montage à la main. Serrez les vis de pression.

Coloque el soporte y el aro de sellado de la ducha de mano sobre la superficie de montaje.

Instale la arandela de fibra, la arandela metálica y la tuerca de montaje en el soporte de la ducha de mano.

Apriete la tuerca de montaje con la mano. Apriete los tornillos tensores.

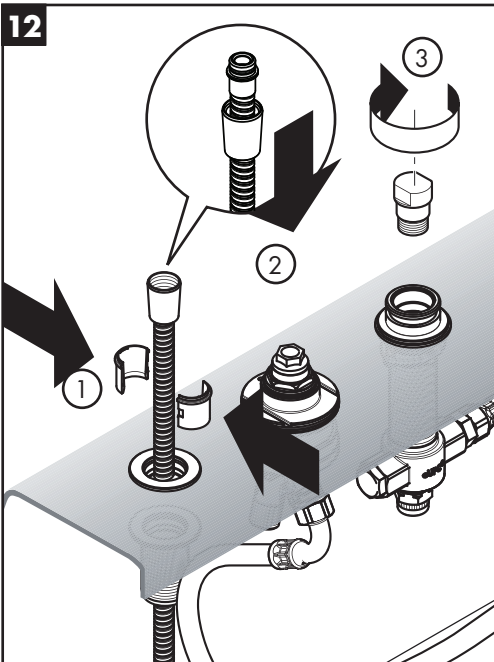
12

Snap the two halves of the insert on the handshower hose.

Push the handshower hose down through the holder.

Install the plug on the spout tee.

Enclenchez les deux moitiés de la pièce d'insertion sur le tuyau de douchette.

Poussez le tuyau dans le support.

Installez le bouchon du raccord en T du bec de remplissage.

Acople a presión las dos mitades del inserto en la manguera de la ducha de mano.

Empuje la manguera hacia abajo a través del soporte.

Retire el tapón de la "T" del surtidor.

13

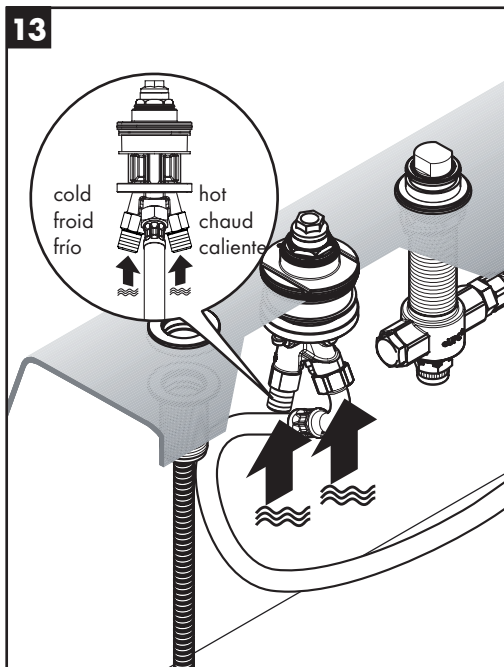

Install the hot and cold water supply lines (not included) on the correct mixing valve inlets. The inlets are marked "hot" and "cold".

⚠ **If the hot and cold supplies are not connected to the correct inlets, the mixing valve will not function correctly.**

Installez les conduites d'alimentation en eau chaude et eau froide (non comprises) sur les orifices d'entrée appropriés du mitigeur. Les orifices d'entrée portent les indications « chaude » et « froide ».

⚠ **Si les conduites d'alimentation en eau chaude et eau froide ne sont pas raccordées dans les bons orifices, le mitigeur ne pourra pas fonctionner correctement.**

Instale las líneas de suministro de agua caliente y fría (no incluidas) en las entradas de la válvula mezcladora adecuadas. Las entradas se marcan como "caliente" y "frío".

⚠ **Si los suministros de agua caliente y fría no están conectados a las entradas correctas, la válvula del mezclador no funcionará correctamente.**

14

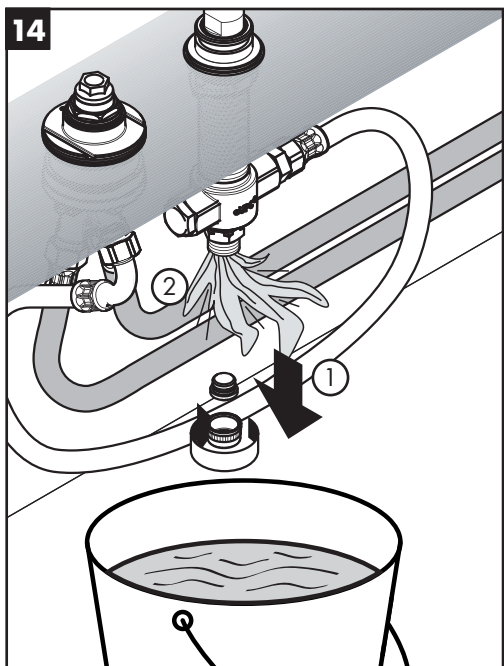

Remove the knurled nut and the sealing plug.

Flush the hot and cold supply lines thoroughly.

Retirez l'écrou moleté et le bouchon d'étanchéité.

Rincez abondamment les conduites d'alimentation en eau chaude et eau froide.

Retire la tuerca moleteada y el tapón de sellado.

Lave bien las líneas de suministro de agua caliente y fría.

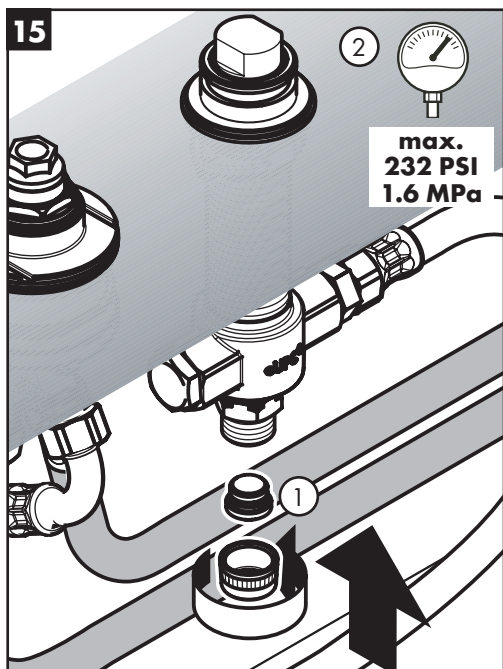

Reinstall the sealing plug and knurled nut.

Pressure test the unit.

Réinstallez le bouchon d'étanchéité et l'écrou moleté.

Testez la pression du produit.

Vuelva a colocar el tapón de sellado y la tuerca moleteada.

Realice una prueba de presión de la unidad.

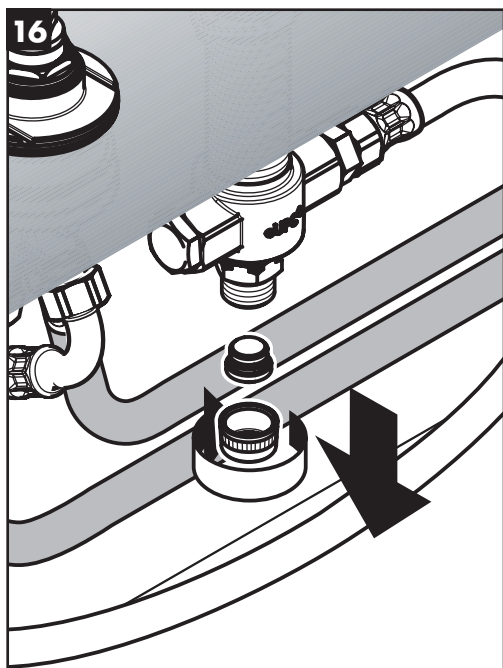

Remove the knurled nut and the sealing plug.

Retirez l'écrou moleté et le bouchon d'étanchéité.

Retire la tuerca moleteada y el tapón de sellado.

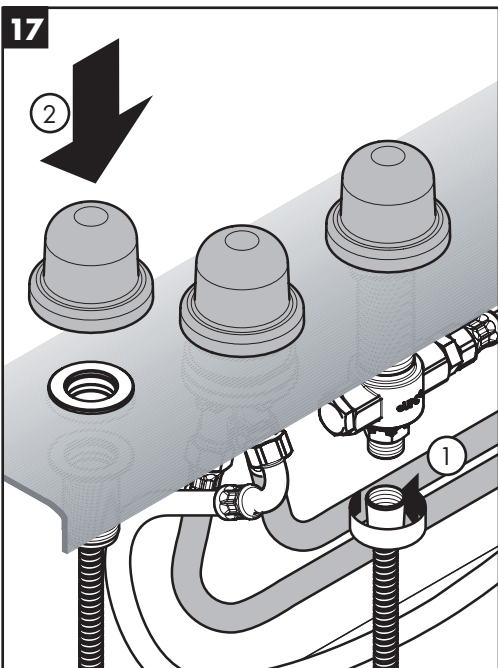

Install the handshower hose.

Install the plaster shields.

Installez le tuyau de douche.

Installez les protecteurs.

Instale la manguera de la ducha de mano.

Instale los escudos de yeso.

Replacement Parts / Pièces détachées / Repuestos

Rough for 3-hole Single Control Bath Mixer 13439181

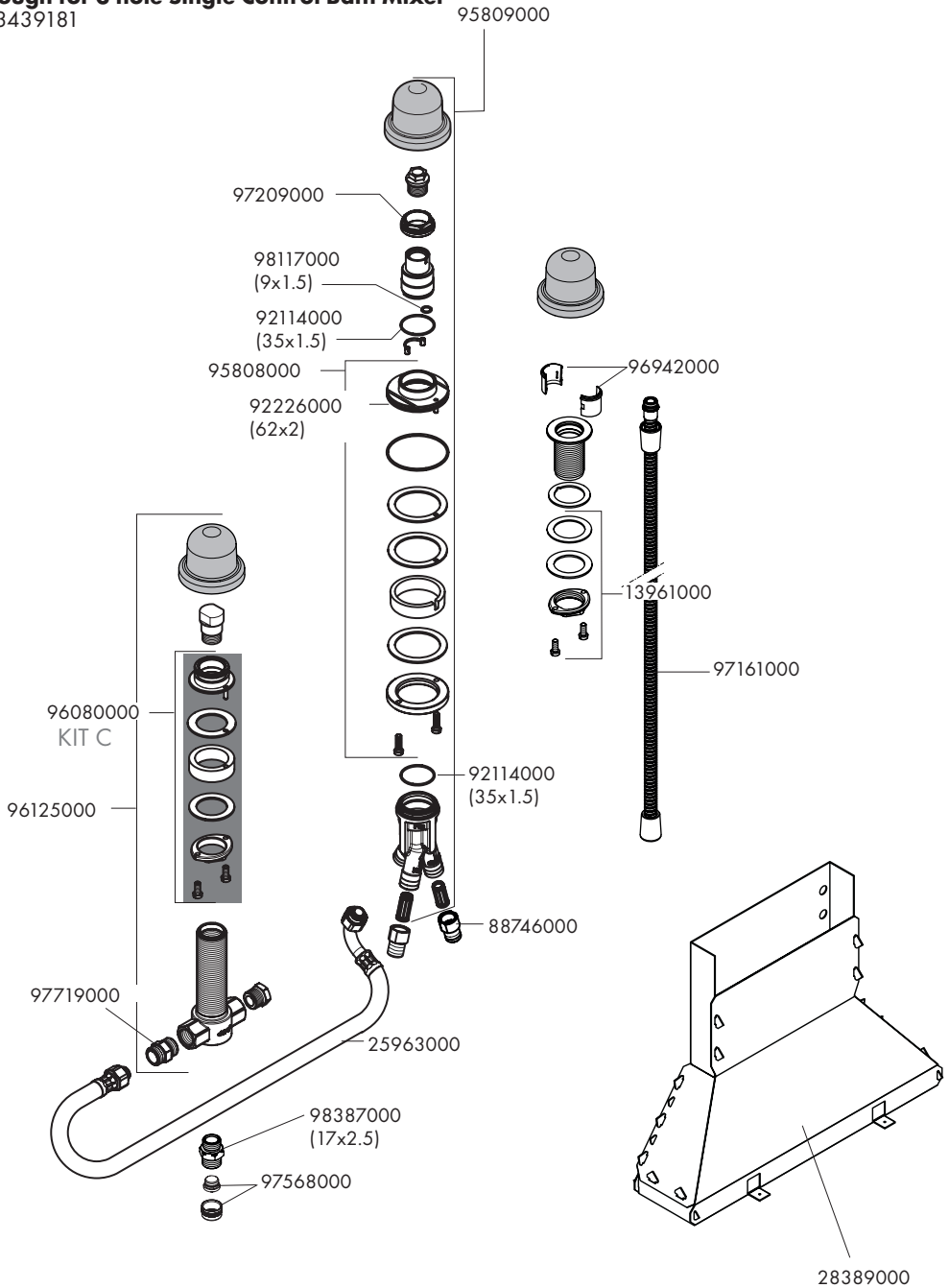

Hansgrohe, Inc. Limited Warranty

Offering our customers the highest quality at all times is a fundamental part of the Hansgrohe, Inc. company philosophy. We offer consumers a limited warranty on our hansgrohe® and AXOR® branded products.

This warranty is limited to products manufactured by Hansgrohe, Inc. that are purchased from a Hansgrohe, Inc. authorized seller by a consumer in the United States or Canada after September 1, 2019, and installed in either the United States or in Canada.

WARRANTY

Hansgrohe, Inc. warrants to the original consumer purchaser that hansgrohe and AXOR products will be free from defects in material and workmanship for as long as the original consumer purchaser owns both the product and the home in which the product was originally installed. For commercial purchasers, the warranty period is (a) one (1) year for hansgrohe products and (b) five (5) years for AXOR products, in each case from the date of purchase. The warranty period for products in the Rubbed Bronze, Matte Black and Matte White finishes are three (3) years from the date of purchase. This warranty is non-transferable.

WHAT WE WILL DO

Hansgrohe, Inc., at its option, will replace any product or part of the product that proves defective in workmanship and/or material, under normal installation, use, service and maintenance. If Hansgrohe, Inc. is unable to provide a replacement part or product and repair is not practical or cannot be made in timely fashion, Hansgrohe, Inc. may elect to refund the purchase price in exchange for the return of the defective product. REPAIR OR REPLACEMENT (OR, IN LIMITED CIRCUMSTANCES, REFUND OF THE PURCHASE PRICE) AS PROVIDED UNDER THIS LIMITED WARRANTY IS THE EXCLUSIVE REMEDY OF THE PURCHASER.

WHAT IS NOT COVERED BY THE WARRANTY

Because Hansgrohe, Inc. is unable to control the quality of hansgrohe or AXOR products sold by unauthorized sellers, unless otherwise prohibited by law, this warranty does not cover hansgrohe or AXOR products purchased from unauthorized sellers. Authorized sellers can be found on hansgrohe and AXOR branded websites.

Labor and other expenses for disconnection, deinstallation, or return of the product for warranty service (including but not limited to proper packaging and shipping costs), or for installation or reinstallation of the product are not covered by this warranty.

Hansgrohe, Inc. shall not be liable for any damage to the product resulting from

- reasonable wear and tear
- outdoor use
- misuse (including use of the product for an unintended application)
- freezing water
- excessive water pressure
- pipe corrosion in the home in which the product is installed

- abuse, neglect or improper or incorrectly performed installation, maintenance or repair, including the use of abrasive or caustic cleaning agents or “no-rinse” cleaning products.

This warranty does not cover: (i) accessories, connected materials and products, or related products not manufactured by Hansgrohe, Inc. (ii) any hansgrohe or AXOR product sold for display purposes or (iii) hansgrohe or AXOR products purchased from unauthorized sellers.

WHAT YOU MUST DO TO OBTAIN WARRANTY SERVICE OR INFORMATION

Contact your retailer, or contact Technical Service at:

Hansgrohe, Inc.
1492 Bluegrass Lakes Parkway
Alpharetta, GA 30004
Toll-free 800 -334- 0455

In requesting warranty service, you will need to provide:

1. The sales receipt or other evidence of the date and place of purchase.
2. A description of the problem.
3. Delivery of the product or the defective part, postage prepaid and carefully packed and insured, to:

Hansgrohe, Inc.
1492 Bluegrass Lakes Parkway
Alpharetta, GA 30004
Toll-free 800 -334- 0455

When warranty service is completed, any repaired or replacement product or part will be returned to you postage prepaid.

REVISED SEPTEMBER 1, 2019.

Limitation on Duration of Implied Warranties: Some States do not allow limitations on how long an implied warranty lasts, so the below limitations may not apply to you. TO THE MAXIMUM EXTENT PERMITTED BY APPLICABLE LAW, ANY IMPLIED WARRANTY, INCLUDING THE IMPLIED WARRANTIES OF MERCHANTABILITY AND OF FITNESS FOR A PARTICULAR PURPOSE, IS LIMITED TO THE STATUTORY PERIOD OR THE DURATION OF THIS WARRANTY, WHICHEVER IS SHORTER.

Limitation of Special, Incidental or Consequential Damages: Some States do not allow the exclusion or limitation of incidental or consequential damages, so the below limitations and exclusions may not apply to you. TO THE MAXIMUM EXTENT PERMITTED BY APPLICABLE LAW, THIS WARRANTY DOES NOT COVER, AND HANSGROHE, INC. SHALL NOT BE LIABLE FOR, ANY SPECIAL, INCIDENTAL OR CONSEQUENTIAL DAMAGES (INCLUDING LABOR CHARGES TO REPAIR, REPLACE, INSTALL OR REMOVE THIS PRODUCT), WHETHER ARISING OUT OF BREACH OF ANY EXPRESS OR IMPLIED WARRANTY, BREACH OF CONTRACT, TORT, OR OTHERWISE. HANSGROHE, INC. SHALL NOT BE LIABLE FOR ANY DAMAGE TO THE PRODUCT RESULTING

FROM REASONABLE WEAR AND TEAR, OUTDOOR USE, MISUSE (INCLUDING USE OF THE PRODUCT FOR AN UNINTENDED APPLICATION), FREEZING WATER, EXCESSIVE WATER PRESSURE, PIPE CORROSION IN THE HOME IN WHICH THE PRODUCT IS INSTALLED, ABUSE, NEGLIGENCE OR IMPROPER OR INCORRECTLY PERFORMED INSTALLATION, MAINTENANCE OR REPAIR, INCLUDING THE USE OF ABRASIVE OR CAUSTIC CLEANING AGENTS OR "NO-RINSE" CLEANING PRODUCTS.

Notice to residents of the State of New Jersey: The provisions of this warranty, including its limitations, are intended to apply to the fullest extent permitted by the laws of the State of New Jersey.

This warranty gives you specific legal rights, and you may also have other rights which vary from state to state.

PRODUCT INSTRUCTIONS AND QUESTIONS

Upon purchase or prior to installation, please carefully inspect your product for any damage or visible defect. Prior to installing, always carefully study the enclosed instructions on the proper installation and the care and maintenance of this product.

If you have questions at any time about the use, installation or performance of your product, or the Limited Warranty, please write us or call us toll-free at 800-334-0455.

hansgrohe

Hansgrohe, Inc. 1490 Bluegrass Lakes Parkway Alpharetta, GA 30004
Tel. 800-334-0455 Fax 770-889-1783

www.hansgrohe-usa.com