

- EN** Instructions for use / Assembly instructions
- FR** Mode d'emploi / Instructions de montage
- ES** Modo de empleo / Instrucciones de montaje

**2**  
**3**  
**4**

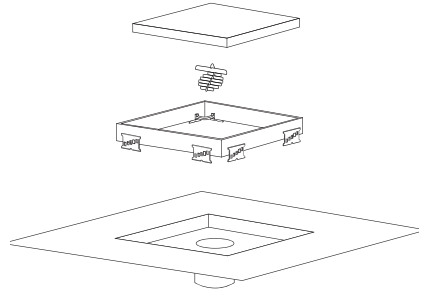

## **Brilliance Zero/Tile/Boardwalk**

56130801/56130671/  
56132801/56134801/  
56134671/56136801

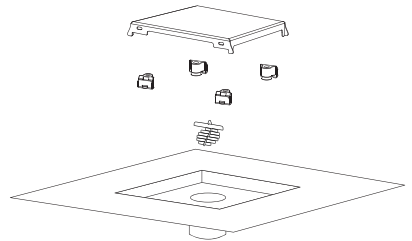

## **Brilliance Stone**

56133001/56137001



## Safety Notes

- △ Gloves should be worn during installation to prevent crushing and cutting injuries.

## Installation Instructions

- Suitable for renovation work and new buildings
- The product should only be installed by specialist companies in compliance with the building regulations.
- To achieve the best possible result, please read the installation guide carefully.
- Before starting the installation, the installation instructions with their specifics should be discussed with the tiler. Please hand all installation instructions to the tiler after installation.
- Prior to installation, inspect the product for transport damages. After it has been installed, no transport or surface damage will be honoured.
- When using the drain in conjunction with several showers, please check if the draining capacity of the drain is adequate.
- We recommend taping off the drain opening of the drain set or closing it with the cement cap before installation to prevent construction debris from getting into the drain pipe.
- To prevent damage to the tile frame, it should be kept in its packaging until final installation by the tiler.
- Align the drain horizontally in all directions.
- The installation of the waste water system must be carried out in accordance with the standards. Pay attention to adequate aeration and ventilation, and an adequate slope in the waste water system.
- Check the drain system and the waste water connections for tightness.
- To prevent any cavities, the drain body must be fully lined and compacted with screed up to the top edge of the flange.
- When laying the floor tiles, the tile slope (min. 2%) in the shower area must always slope towards the drain. The tiles must be laid flush or 1 mm higher than the top edge of the tile frame. This ensures good drainage towards the drain set. Other requirements regarding the slope may apply for floor-level showers with glass walls. The manufacturer's specifications must be observed.
- After tiling, the transition between the tiled floor and the drain must be sealed with a permanently elastic joint (maintenance joint). The bonding surfaces must be free of mortar, adhesive and other adhesion-inhibiting materials.

- The drain is only suitable for normal domestic waste water. Avoid other liquids as well as cleaning agents that can damage sanitary fittings, draining facilities and pipe materials.
- When using the drain in other areas (e.g. swimming pools) where the drain may come into contact with aggressive cleaning agents or corrosive substances such as salt or chlorine, please contact the manufacturer.
- Compliance with this installation recommendation is required to make any warranty claims based on our terms and conditions of sale and delivery.
- Products containing chlorine or acids, such as cement residue remover or similar, often contain aggressive chemicals. These can corrode the surface of the product. Bleaches or silver cleaning agents are also unsuitable for stainless steel care. When using tile and joint cleaners, the product must subsequently be cleaned with adequate amounts of clear water. The product cannot be cleaned with abrasive cleaners and / or pointed or abrasive objects. Clean brushed or ground surfaces always parallel to the grind instead of across it.

## Symbol description



Do not use silicone containing acetic acid!



**Dimensions** (see page 5)



**Cleaning** (see page 18)

- Before cleaning, remove all parts of the siphon and clean them separately using only mild detergents.



## Consignes de sécurité

- △ Lors du montage, porter des gants de protection pour éviter toute blessure par écrasement ou coupure.

## Instructions pour le montage

- Convient à la rénovation et aux constructions neuves
- Le produit ne devrait être installé que par des entreprises spécialisées, en tenant compte des règlements relatifs à la technique de construction.
- Pour un résultat optimal, lire attentivement les instructions de montage.
- Avant de commencer le montage, les consignes et particularités du montage doivent être discutées avec le carreleur. Après le montage, remettre toutes les instructions de montage au carreleur.
- Avant son montage, s'assurer que le produit n'a subi aucun dommage pendant le transport. Après le montage, tout dommage de transport ou de surface ne pourra pas être reconnu.
- En cas d'utilisation de l'écoulement en liaison avec plusieurs douches, vérifier si la capacité d'écoulement s'avère suffisante.
- Nous recommandons d'obtenir l'orifice d'écoulement de la garniture d'écoulement avant le montage ou de le fermer à l'aide du capuchon en ciment, afin d'éviter l'infiltration d'impuretés dans la conduite d'écoulement.
- Pour éviter tout dommage, le cadre du carrelage devrait rester dans son emballage jusqu'à ce que le carreleur ait terminé le montage.
- Aligner l'écoulement à l'horizontale dans tous les sens.
- Le système d'évacuation des eaux usées doit être installé conformément aux normes. Respecter l'aération et la ventilation, ainsi qu'une pente suffisante dans le système d'évacuation des eaux usées.
- Vérifier l'étanchéité du système d'écoulement et des raccords d'eaux usées.
- Afin d'éviter des cavités, le corps d'écoulement doit être étayé et entièrement scellé à l'aide d'une chape jusqu'au bord supérieur de la bride.
- Lors de la pose du carrelage, la pente du carrelage (2 % au moins) dans la zone de la douche doit toujours être dirigée vers l'écoulement. Les carreaux doivent être posés à la même hauteur ou 1 mm plus haut que le bord supérieur du cadre des carreaux. Ceci permet d'assurer un bon drainage vers la robinetterie d'écoulement. Pour les douches à même le sol avec des parois en verre, il est possible que d'autres impératifs s'appliquent à la

pente. Les spécifications du fabricant doivent être respectées.

- Après la pose du carrelage, la transition entre le sol carrelé et l'écoulement doit être scellée à l'aide d'un joint à élasticité permanente (joint d'entretien). Les surfaces de collage doivent être exemptes de mortier, de colle et d'autres matériaux susceptibles de réduire l'adhérence.
- L'écoulement ne convient qu'aux eaux usées domestiques normales. Éviter tout autre liquide et détergent risquant d'endommager les appareils sanitaires, le matériel de drainage et les matériaux des conduits.
- Si l'écoulement est utilisé à d'autres endroits (piscines, p. ex.) où il risque d'entrer en contact avec des détergents agressifs ou des substances favorisant la corrosion, telles que le sel ou le chlore, contacter le fabricant.
- Le respect de la présente recommandation de montage constitue la condition préalable à une demande de garantie basée sur nos conditions générales de vente.
- Les produits à base de chlore ou d'acide, tels que les dissolvants de résidus de ciment ou produits similaires, contiennent souvent des produits chimiques agressifs. Ceux-ci risquent d'attaquer la surface du produit. L'eau de Javel ou les produits de nettoyage pour l'argent ne conviennent pas non plus à l'entretien de l'acier inoxydable. En cas d'utilisation de détergents pour carreaux et joints, le produit doit être ensuite abondamment rincé à l'eau claire. Le produit ne peut pas être nettoyé avec des produits à récurer et/ou des objets pointus ou abrasifs. Pour les surfaces brossées ou poncées, toujours nettoyer parallèlement non à la transversale par rapport au ponçage.

## Description du symbole



Ne pas utiliser de silicone contenant de l'acide acétique!



**Dimensions** (voir pages 5)

**Nettoyage** (voir pages 18)

- Avant le nettoyage, retirer toutes les parties du siphon et les nettoyer séparément et uniquement à l'aide de détergents doux.



## Indicaciones de seguridad

⚠ Durante el montaje deben utilizarse guantes para evitar heridas por aplastamiento o corte.

## Indicaciones para el montaje

- Apto para renovación y nueva construcción
- El montaje del producto debe realizarlo únicamente una empresa especializada, teniendo en cuenta la legislación vigente en materia de técnica de construcción.
- Para un resultado óptimo lea atentamente las instrucciones de montaje.
- Antes de comenzar el montaje deberían consultarse con el alicatador las instrucciones de montaje con sus peculiaridades. Tras el montaje entregue todas las instrucciones de montaje al alicatador.
- Antes del montaje se debe examinarse el producto contra daños de transporte. Después de la instalación no se reconoce ningún daño de transporte o de superficie.
- Si utiliza el desagüe en combinación con varias duchas, compruebe si el desagüe cuenta con suficiente capacidad de descarga.
- Le recomendamos pegar el orificio de desagüe de la grifería de desagüe, o cerrar la tapa de cemento, para evitar contaminación en el conducto de desviación.
- Para evitar daños el marco de las baldosas debe permanecer en su embalaje hasta que el alicatador lo monte definitivamente.
- El desagüe debe estar horizontalmente alineado, en todas las direcciones.
- La instalación del sistema de desagüe debe cumplir todas las normas. Respete también la ventilación y la desaireación y deje suficiente pendiente en el sistema de desagüe.
- Compruebe la estanqueidad del sistema de descarga y de las conexiones de desagüe.
- Para evitar huecos, debe rellenarse y obturarse completamente el cuerpo de descarga con el encofrado, hasta la brida del borde superior.
- Al colocar las baldosas del suelo, el desnivel de las baldosas (mínimo 2%) del área de la ducha siempre debe correr hacia el desagüe. Las baldosas deben colocarse a la misma altura o 1 mm más altas que el borde superior del marco. Así se garantiza un buen desagüe hacia el drenaje. En caso de duchas a ras del suelo con paneles de vidrio, es posible que para los desniveles sea necesario tener en cuenta otros

requisitos. Debe respetarse las instrucciones del fabricante.

- Tras alicatar el paso entre el suelo de baldosas y el desagüe debe impermeabilizarse con una junta elástica permanente (junta con mantenimiento). Las superficies de adhesión deben estar libres de mortero, adhesivo y otros materiales que disminuyan la adhesión.
- El desagüe solamente puede transportar las aguas residuales domésticas habituales. Evite cualquier otro líquido y productos de limpieza, que puedan dañar el equipamiento sanitario, los elementos del desagüe y el material de las tuberías.
- Si se utiliza el desagüe en otras áreas (por ejemplo, en piscinas), en las que la descarga entra en contacto con productos de limpieza agresivos o sustancias corrosivas, tales como sal o cloro, póngase en contacto con el fabricante.
- El cumplimiento de esta recomendación de montaje es requisito previo para cualquier reclamación de garantía, basada en nuestras Condiciones de venta y entrega.
- Los productos ácidos o con cloro tales como el eliminador de residuos de cemento, o similar, suelen contener productos químicos agresivos. Esos químicos podrían dañar la superficie del producto. Los limpiadores para plata o clorados no se pueden utilizar para cuidar el acero fino. Si se utilizan limpiadores de baldosa o juntas debe aclararse después el producto usando suficiente agua limpia. El producto no se puede limpiar con limpiadores abrasivos ni con objetos afilados, puntiagudos o abrasivos. En caso de superficies cepilladas o pulidas limpiar siempre en paralelo y nunca transversal respecto al acabado.

## Descripción de símbolos



No utilizar silicona que contiene ácido acético!



**Dimensiones** (ver página 5)



**Limpiar** (ver página 18)

- Antes de realizar la limpieza retire todas las piezas del sifón y límpielas por separado y usando únicamente productos de limpieza suaves.

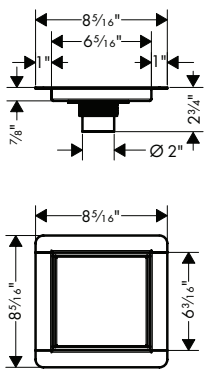
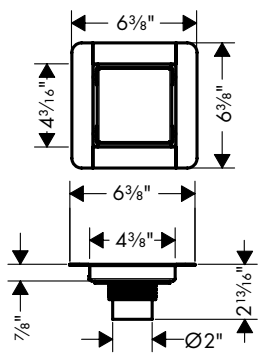

**Brilliance Stone**  
56133001/56137001

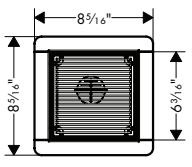
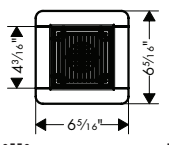
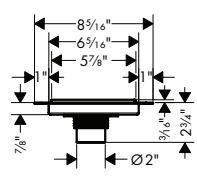
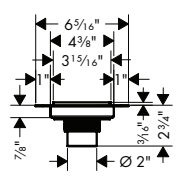

**Brilliance Boardwalk**  
56132801/56136801

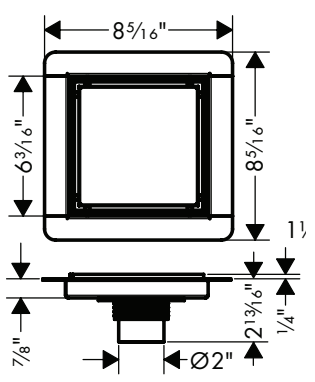
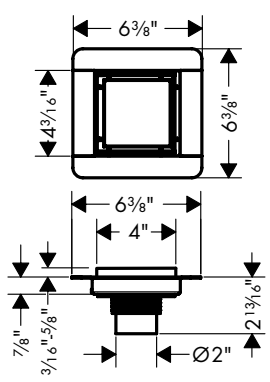

**Brilliance Zero/Tile**  
56130801/56130671/56134801/56134671



---

**Installation - Clamp drain**



**Installation - No-hub sleeve**





# Installation - Clamp drain

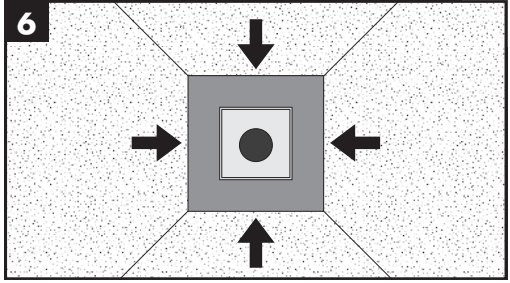
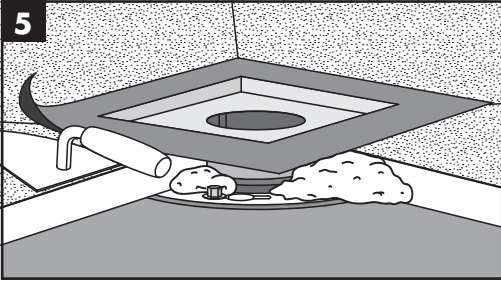
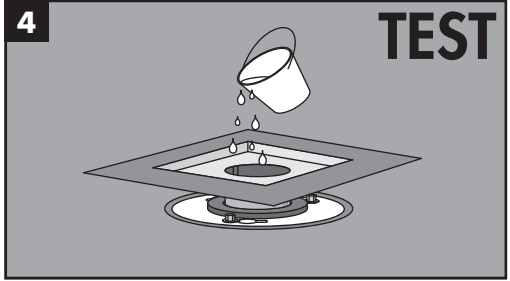
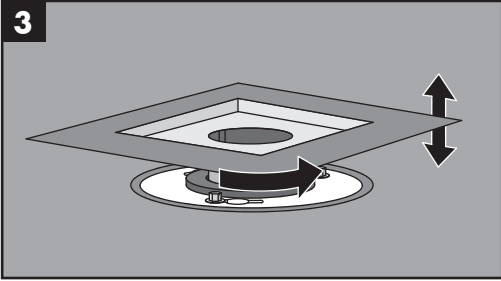
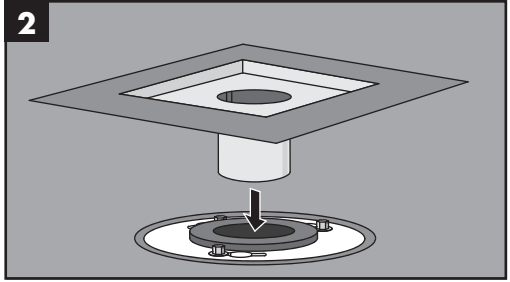
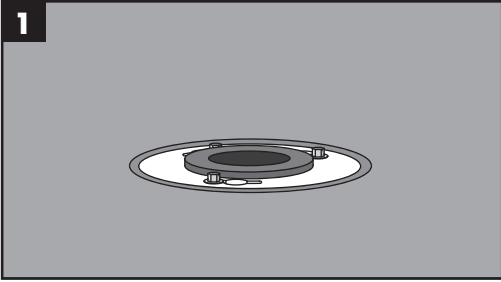

**Zero/Boardwalk** →  **9**

**Stone** →  **12**



## Installation - No-hub sleeve

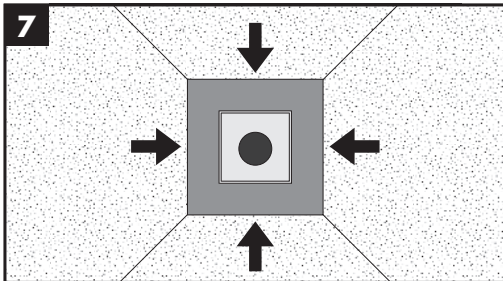
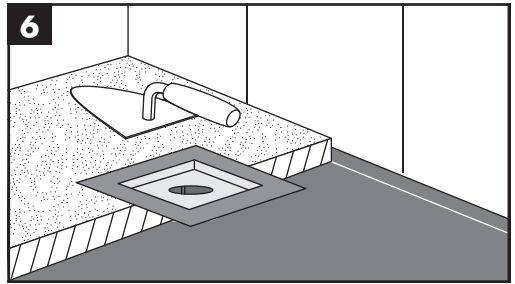
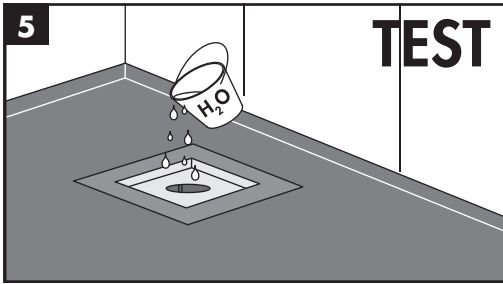
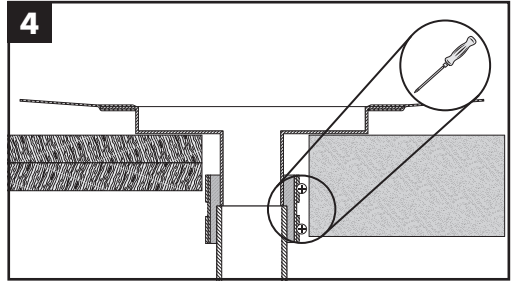
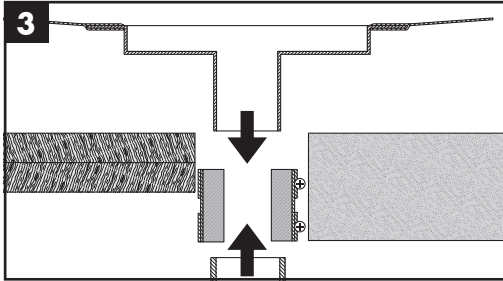
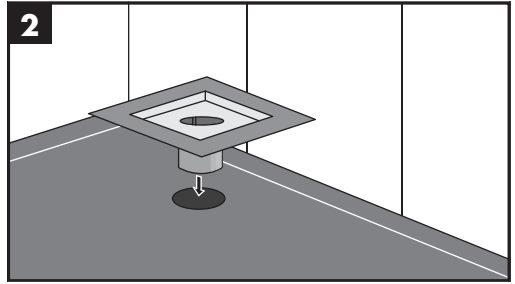
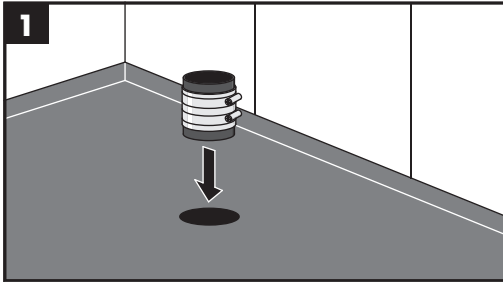





## Installation - Zero/Tile/Boardwalk

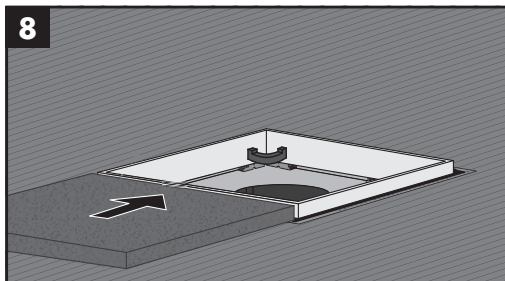
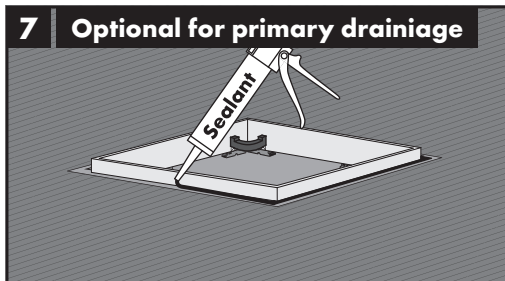
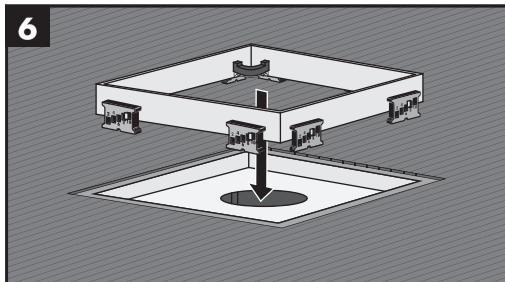
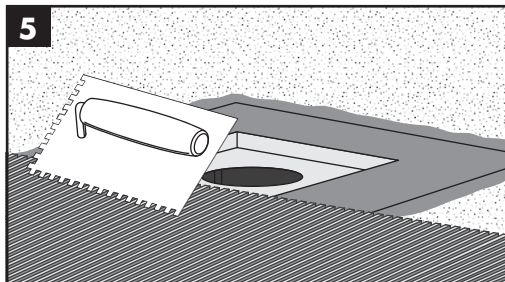
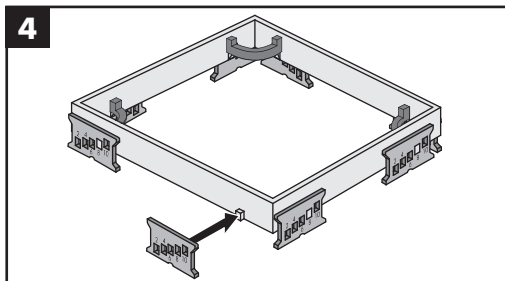
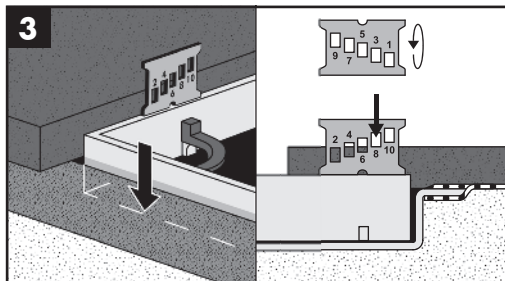
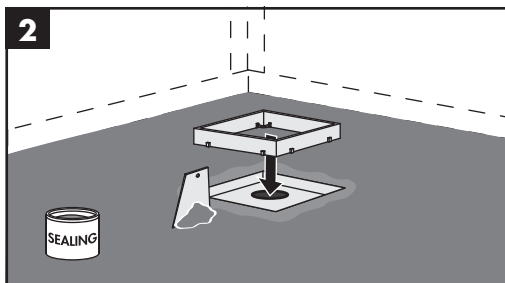
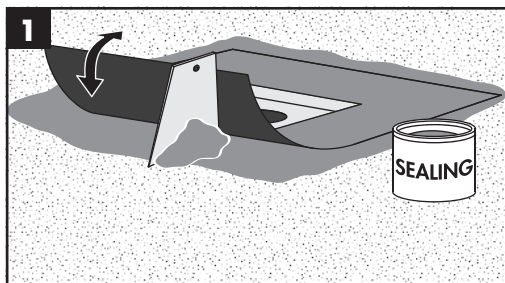

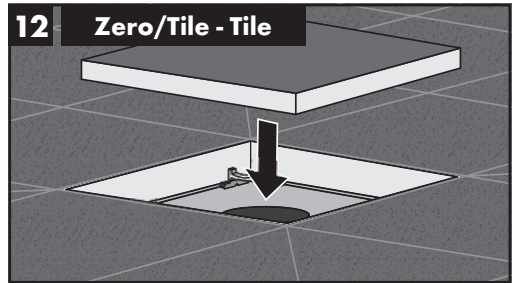
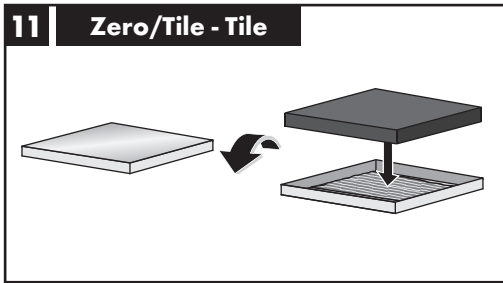
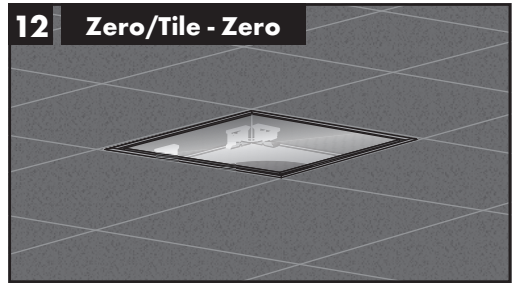
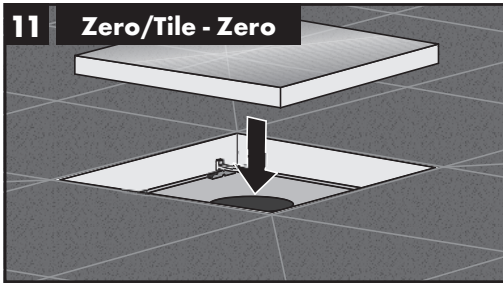
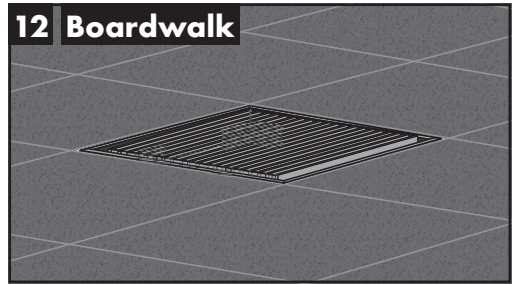
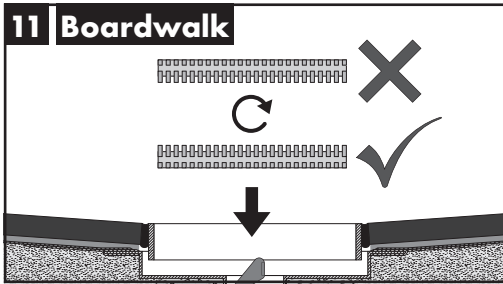
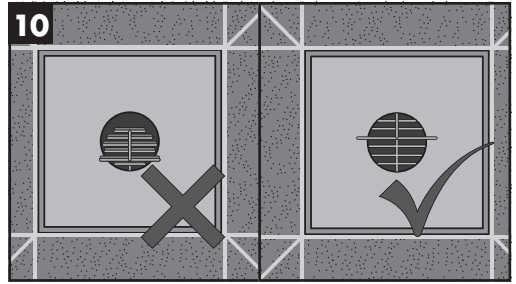
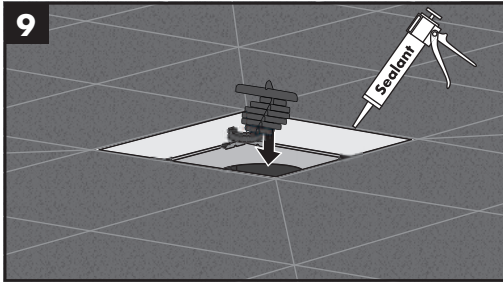



---

**13** Zero/Tile - Tile

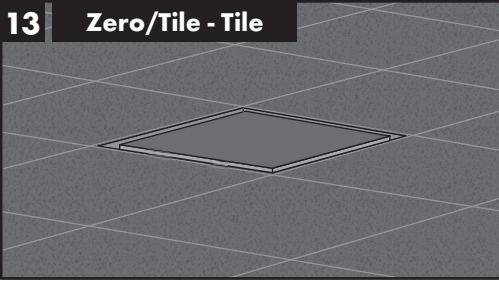



## Installation - Stone

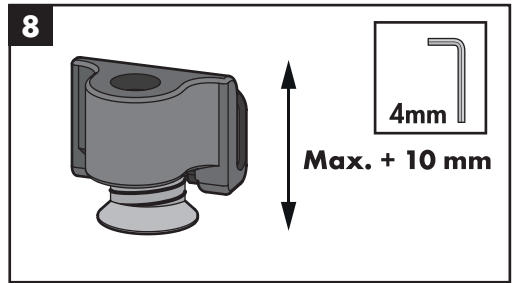
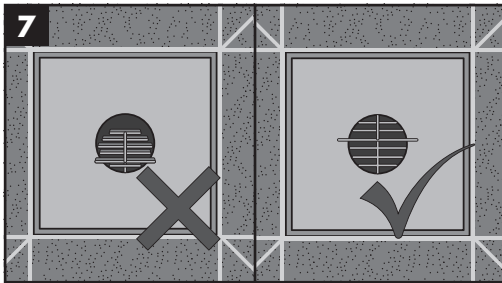
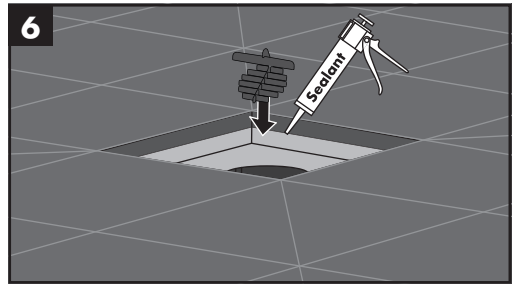
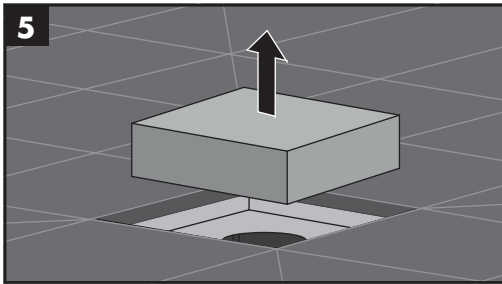
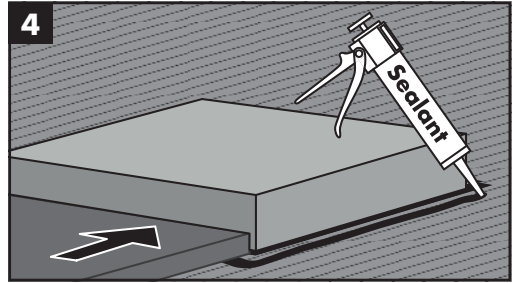
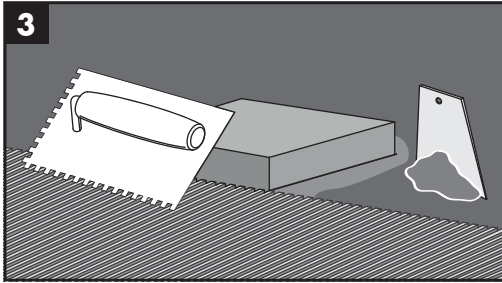
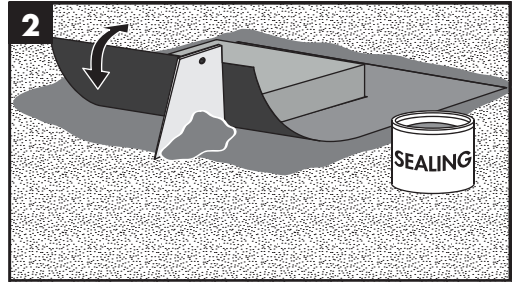
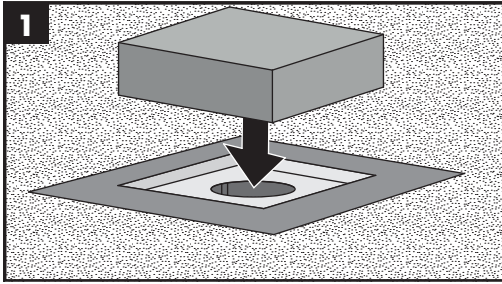

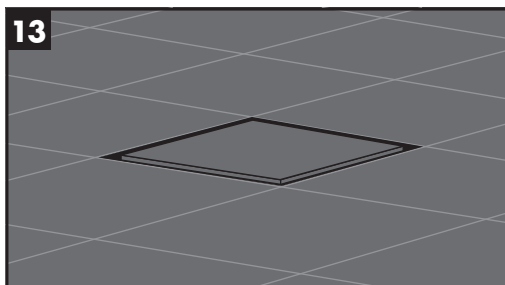
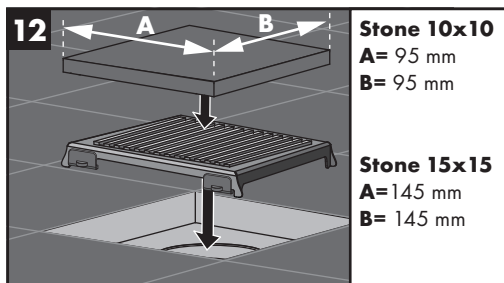
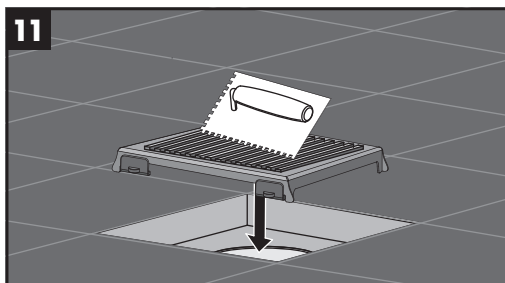
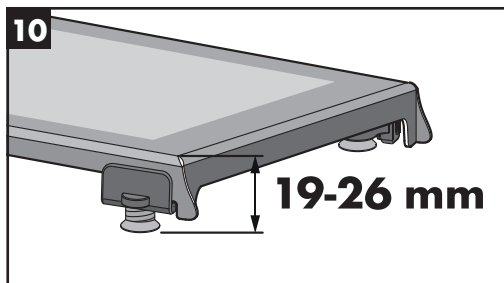
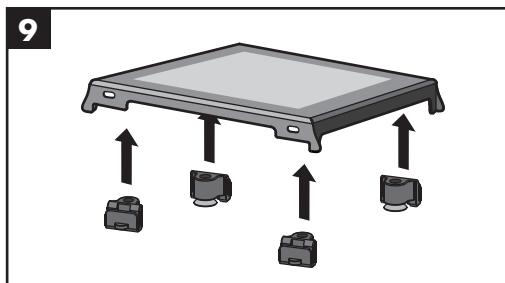



## Sealing advice - Clamp drain

## Zero/Tile

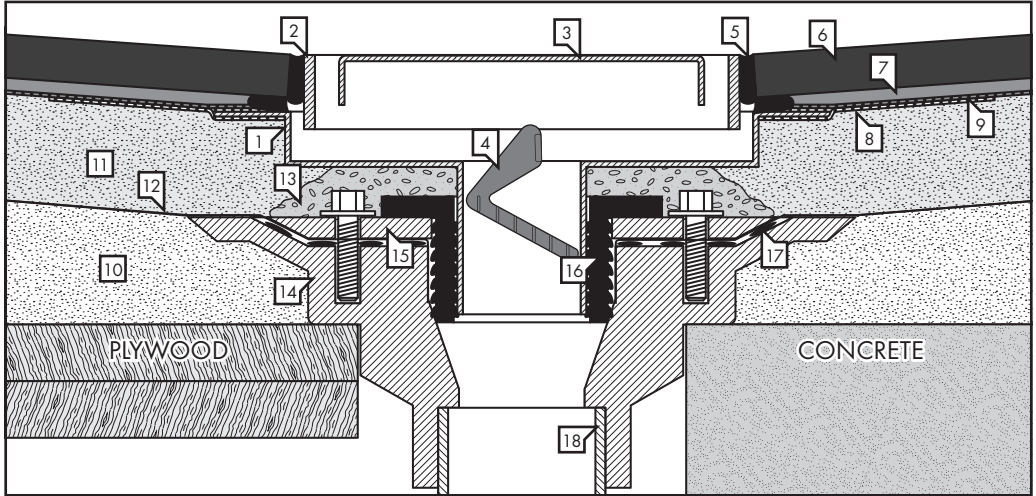

	EN	FR	ES
1	Brilliance drain body	Brilliance élément d'encastrement	Cuerpo de desagüe Brilliance
2	TAF (Tile Adjustable Frame)	TAF ( cadre d'ajustment supérieur )	TAF (marco ajustable a baldosa)
3	TAF Grating	TAF grille	Rejilla TAF
4	Strainer	Grille	Recogedor de pelos
5	Elastic sealant - Silicone	Silicone d'étanchéité	Sellador elástico - Silicona
6	Tiles	Carrelage	Losas
7	Thin set tile adhesive	Colle à carrelage	Adhesivo para baldosas de fraguado fino
8	Pre-assembled waterproofing membrane	Natte d'étanchéité flexible assemblée en usine	Membrana impermeabilizante premontada
9	Thin-set sheet membrane (entire floor!)	Natte d'étanchéité de base	Membrana de lámina delgada (ipiso entero!)
10	Sloped mortar bed - first layer	Chape de béton flottant primaire	Con pendiente lecho de mortero - la primera capa
11	Sloped mortar bed - second layer	Chape de béton flottant secondaire	Con pendiente lecho de mortero - segunda capa
12	Pan liner / Moisture resistant material	Double natte / résistant à l'humidité	Revestimiento / Material resistente a la humedad
13	Pea Gravel	Béton d'installation	Grava
14	2" Clamping drain base*	2" Base de drainage	Base de drenaje de sujeción de 2"*
15	2" Clamping ring*	2" Bague de serrage	Anillo de sujeción de 2"*
16	2" Rubber sealing gasket	2" joint d'étanchéité en caoutchouc	Junta de sellado de goma de 2"
17	Sealant between membrane & mortar	Scellant entre natte et chape	Sellador entre membrana y mortero
18	Drainage pipe	Sortie d'évacuation	Tubo de drenaje

\*Not included with the drain.



## Sealing advice - No-hub sleeve

## Zero/Tile

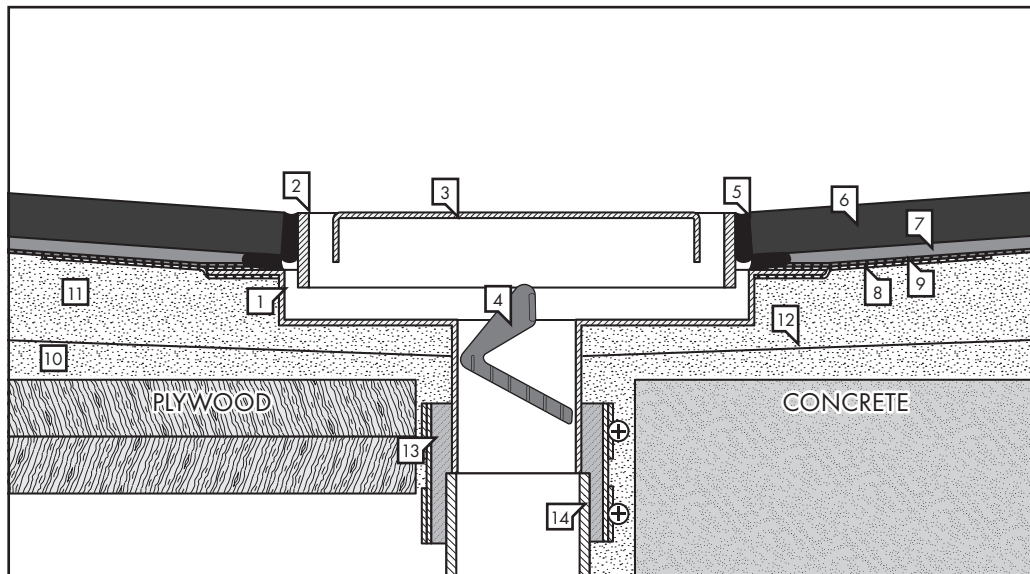

EN	FR	ES
1 Brilliance drain body	Brilliance élément d'encastrement	Cuerpo de desagüe Brilliance
2 TAF (Tile Adjustable Frame)	TAF ( cadre d'ajustment supérieur )	TAF (marco ajustable a baldosa)
3 TAF Grating	TAF grille	Rejilla TAF
4 Strainer	Grille	Recogedor de pelos
5 Elastic sealant - Silicone	Silicone d'étanchéité	Sellador elástico - Silicona
6 Tiles	Carrelage	Losas
7 Thin set tile adhesive	Colle à carrelage	Adhesivo para baldosas de fraguado fino
8 Pre-assembled waterproofing membrane	Natte d'étanchéité flexible assemblée en usine	Membrana impermeabilizante premontada
9 Thin-set sheet membrane (entire floor!)	Natte d'étanchéité de base	Membrana de lámina delgada (piso entero!)
10 Sloped mortar bed - first layer	Chape de béton flottant primaire	Con pendiente lecho de mortero - la primera capa
11 Sloped mortar bed - second layer	Chape de béton flottant secondaire	Con pendiente lecho de mortero - segunda capa
12 Pan liner / Moisture resistant material	Double natte / résistant à l'humidité	Revestimiento / Material resistente a la humedad
13 No-Hub sleeve*	Manchon sans moyeu*	Manga sin buje*
14 Drainage pipe	Sortie d'évacuation	Tubo de drenaje

\*Not included with the drain.



## Sealing advice - Clamp drain

## Stone

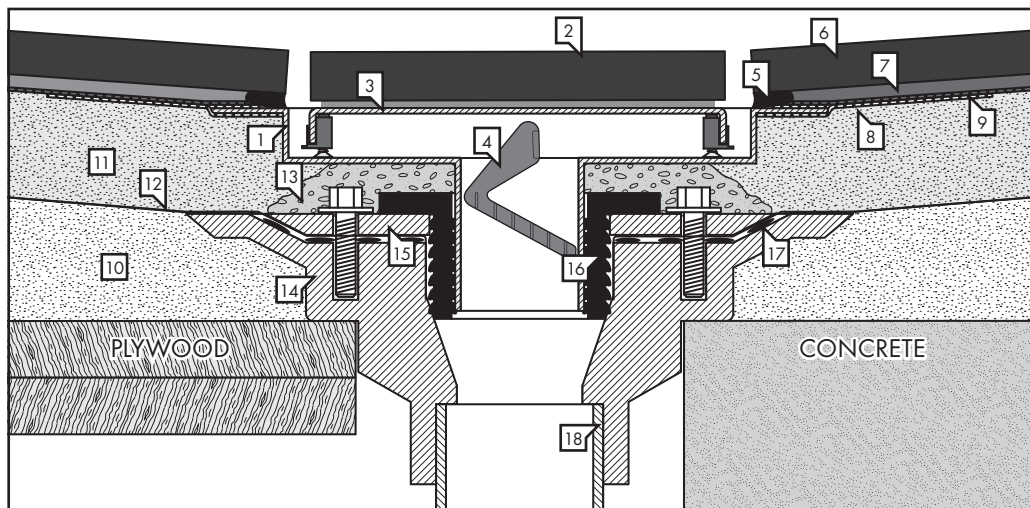

	EN	FR	ES
1	Brilliance drain body	Brilliance élément d'encastrement	Cuerpo de desagüe Brilliance
2	Tile	Tuile	Loseta
3	Grate	Grille	Rallar
4	Strainer	Piège "attrape-cheveux"	Recogedor de pelos
5	Elastic sealant	d'étanchéité	Sellador elástico
6	Tiles	Carrelage	Losas
7	Thin set tile adhesive	Colle à carrelage	Adhesivo para baldosas de fraguado fino
8	Pre-assembled waterproofing membrane	Natte d'étanchéité flexible assemblée en usine	Membrana impermeabilizante premontada
9	Thin-set sheet membrane (entire floor!)	Natte d'étanchéité de base	Membrana de lámina delgada (ipiso entero!)
10	Sloped mortar bed - first layer	Chape de béton flottant primaire	Con pendiente lecho de mortero - la primera capa
11	Sloped mortar bed - second layer	Chape de béton flottant secondaire	Con pendiente lecho de mortero - segunda capa
12	Pan liner / Moisture resistant material	Double natte / résistant à l'humidité	Revestimiento / Material resistente a la humedad
13	Pea Gravel	Béton d'installation	Grava
14	2" Clamping drain base*	2" Base de drainage	Base de drenaje de sujeción de 2"*
15	2" Clamping ring*	2" Bague de serrage	Anillo de sujeción de 2"*
16	2" Rubber sealing gasket	2" joint d'étanchéité en caoutchouc	Junta de sellado de goma de 2"
17	Sealant between membrane & mortar	Scellant entre natte et chape	Sellador entre membrana y mortero
18	Drainage pipe	Sortie d'évacuation	Tubo de drenaje

\*Not included with the drain.





## Sealing advice - No-hub sleeve

## Stone

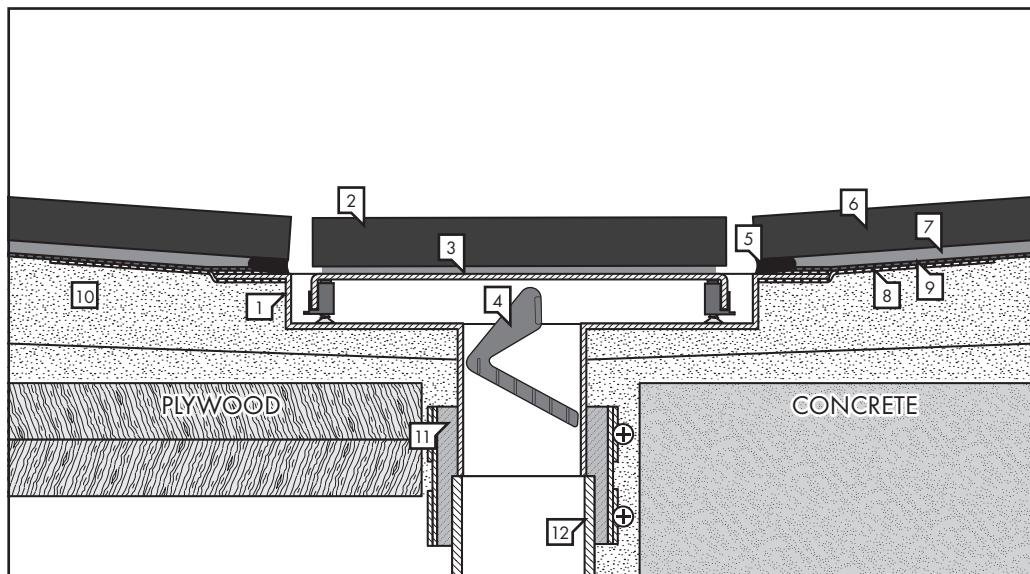

EN	FR	ES
1 Brilliance drain body	Brilliance élément d'encastrement	Cuerpo de desagüe Brilliance
2 Tile	Tuile	Loseta
3 Grate	Grille	Rallar
4 Strainer	Piège "attrape-cheveux"	Recogedor de pelos
5 Elastic sealant	d'étanchéité	Sellador elástico
6 Tiles	Carrelage	Losas
7 Thin set tile adhesive	Colle à carrelage	Adhesivo para baldosas de fraguado fino
8 Pre-assembled waterproofing membrane	Natte d'étanchéité flexible assemblée en usine	Membrana impermeabilizante premontada
9 Thin-set sheet membrane (entire floor!)	Natte d'étanchéité de base	Membrana de lámina delgada (ipiso entero!)
10 Sloped mortar bed	Chape de béton flottant	Con pendiente lecho de mortero
11 No-Hub sleeve *	Manchon sans moyeu*	Manga sin buje*
12 Drainage pipe	Sortie d'évacuation	Tubo de drenaje

\*Not included with the drain.



**FR** Recommandation pour le nettoyage / Garanties / Contact

**EN** Cleaning recommendation / Warranty / Contact

**ES** Recomendaciones para la limpieza / Garantía / Contacto



[www.hansgrohe.com/  
cleaning-recommendation](http://www.hansgrohe.com/cleaning-recommendation)



[www.hansgrohe.com/  
cleaning-recommendation](http://www.hansgrohe.com/cleaning-recommendation)



[www.hansgrohe.com/  
cleaning-recommendation](http://www.hansgrohe.com/cleaning-recommendation)



[www.hansgrohe.com/  
cleaning-recommendation](http://www.hansgrohe.com/cleaning-recommendation)





AA005

**hansgrohe**

Hansgrohe · AuestraÙe 5 · 9 · D-77761 Schiltach · Telefon +49 (0) 78 36/51-1282 · Telefax +49 (0) 7836/511440  
E-Mail: [info@hansgrohe.com](mailto:info@hansgrohe.com) · Internet: [www.hansgrohe.com](http://www.hansgrohe.com)

2022-07-11  
90888221  
AA005