

Class 125 3% Nickel Iron Body Gate Valves

Bolted Bonnet • Outside Screw and Yoke • Solid Wedge • Stainless Steel Trim

125 PSI/8.6 Bar Fluid Pressure to 450° F/232° C
200 PSI/13.8 Bar Non-Shock Cold Working Pressure
to -20° F to 150° F/-29° C to 66° C ◆

CONFORMS TO MSS SP-70

MATERIAL LIST

PART	SPECIFICATION
1. Stem	ASTM A 276 S31600SS
2. Handwheel Nut	Ductile Iron ASTM A536
3. Identification Plate	Aluminum
4. Yoke Bushing	Ductile Iron ASTM A536
5. Handwheel	Cast Iron ASTM A126 Class B
6. Bonnet Cap Nut	Steel ASTM A563
7. Bonnet Cap	Ductile Iron ASTM A536
8. ¹ Bonnet	ASTM A126 3% Nickel Iron Class B
9. Bonnet Cap Bolt	Steel ASTM A307
10. Gland Follower Nut	Steel ASTM A563
11. Gland Follower	Ductile Iron ASTM A536
12. Packing Gland	ASTM A276 S31600SS
13. Packing	PTFE Braided Synthetic Fiber
14. Gland Follower Bolt	Steel ASTM A307
15. Backseat Bushing	ASTM A276 S31600SS
16. Body Nut	Steel ASTM A563
17. Body Bolt	Steel ASTM A307
18. Wedge Pin	ASTM A276 S31600SS
19. Body	ASTM A126 3% Nickel Iron Class B
20. Seat Ring	ASTM A351 CF8M Stainless
21. Wedge Face Ring	ASTM A351 CF8M Stainless
22. ² Wedge	ASTM A126 3% Nickel Iron Class B
23. Body Gasket	Synthetic Fibers
24. Stem Collar	ASTM A276 S31600SS
25. Grease Fitting	Alemite 1743B (not shown)

¹ Sizes thru 8" made with Yoke Integral with Bonnet. 10" and 12" sizes made with separate Yoke Bolted to Bonnet.

² Sizes 2" thru 3" have Solid ASTM A 351 CF8M Wedges. Sizes 4" thru 12" made with ASTM A126 3% Ni-Iron Wedge with ASTM A351 CF8M Wedge Face Rings.



F-617-13
Flanged

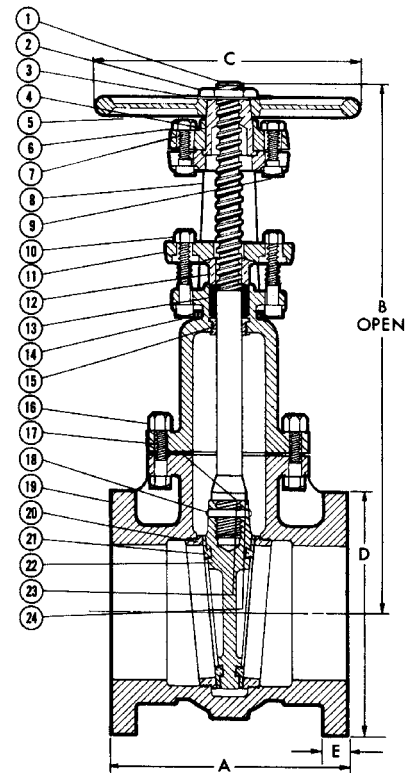

F-617-13
Flg x Flg

DIMENSIONS—WEIGHTS—QUANTITIES

Size	Dimensions										Weight		
	A		B		C		D		E		Lbs.	Kg.	
In.	mm.	In.	mm.	In.	mm.	In.	mm.	In.	mm.	In.	mm.	Lbs.	Kg.
2	50	7.00	178	16.31	414	8.00	203	6.00	152	.63	16	41	19
2½	65	7.50	191	17.19	437	8.00	203	7.00	178	.69	17	54	25
3	80	8.00	203	19.50	495	8.00	203	7.50	191	.75	19	66	30
4	100	9.00	229	24.00	610	10.00	254	9.00	229	.94	24	109	49
6	150	10.50	267	31.06	789	12.00	305	11.00	279	1.00	25	179	81
8	200	11.50	292	40.19	1021	14.00	356	13.50	343	1.13	29	309	140
10	250	13.00	330	48.25	1226	16.00	406	16.00	406	1.19	30	481	218
12	300	14.00	356	56.88	1445	18.00	457	19.00	483	1.25	32	706	320

FREEZING WEATHER PRECAUTION: Subsequent to testing a piping system, valves should be left in an open position to allow complete drainage.

◆ For detailed Operating Pressure, refer to Pressure Temperature Chart on page 114.

VISIT WWW.NIBCO.COM FOR CURRENT CHEM-GUIDE AND GALVANIC POTENTIAL IN PIPING SYSTEMS INFORMATION.

Visit our website for the most current information.