

Class 125 Iron Body Gate Valves

Bolted Bonnet • Non-Rising Stem • Solid Wedge • Bronze Mounted

125 PSI/8.6 Bar Saturated Steam to 353° F/178° C
200 PSI/13.8 Bar Non-Shock Cold Working Pressure
to -20° F to 150° F/-29° C to 66° C◆

CONFORMS TO MSS SP-70

MATERIAL LIST

PART	SPECIFICATION
1. Handwheel Nut	Steel ASTM A307
2. Identification Plate	Aluminum
3. Handwheel or Square Operating Nut	Cast Iron ASTM A126 Class B
4. Stem	Brass ASTM B16 Alloy C36000
5. Gland Follower Nut	Bronze ASTM F467 Alloy C27000
6. Gland Follower	Cast Iron ASTM A126 Class B or Ductile Iron ASTM A536
7. Gland Follower Bolt	Steel ASTM A307
8. Packing Gland	Zinc Plated Powdered Iron ASTM B783 or Brass ASTM B16
9. Stuffing Box	Cast Iron ASTM A126 Class B
10. Packing	Synthetic Fibers with Graphite
11. Stuffing Box Gasket	Synthetic Fibers
12. Bonnet	Cast Iron ASTM A126 Class B
13. Body Bolt	ASTM A307
14. Body Gasket	Synthetic Fibers
15. Body Nut	Steel ASTM A307
16. ¹ Wedge Bushing	Cast Bronze ASTM B584 Alloy C84400
17. Seat Ring	Cast Bronze ASTM B584 Alloy C84400
18. Wedge Face Ring	Cast Bronze ASTM B584 Alloy C84400
19. ¹ Wedge	Cast Iron ASTM A126 Class B
20. Body	Cast Iron ASTM A126 Class B
21. Stuffing Box Nut	Steel ASTM A307 (not shown)

¹ Sizes thru 6" have Bronze Wedges. Sizes 8" thru 16" made with Cast Iron Wedge with Bronze Bushing and Wedge Face Rings.

NOTE: 14" thru 16" Maximum Steam Rating 100 PSI/6.9 Bar
Maximum Non-Shock Cold Working Pressure 150 PSI/10.3 Bar

DIMENSIONS—WEIGHTS—QUANTITIES

Dimensions												F-619		T-619			
Size	F-619		T-619		B	C	D	E	F-619	T-619	F-619	T-619					
	A	A	A	A									Lbs.	Kg.	Lbs.	Kg.	
2	50	7.00	178	5.63	143	11.00	279	7	178	6.00	152	.63	16	35	16	25	11
2½	65	7.50	191	5.88	149	12.50	318	7	178	7.00	178	.69	17	49	22	33	15
3	80	8.00	203	6.13	156	13.50	343	8	203	7.50	191	.75	19	60	27	42	19
4	100	9.00	229	6.50	165	15.75	400	10	254	9.00	229	.94	24	90	41	61	28
5	125	10.00	254	x	x	17.00	432	10	254	10.00	254	.94	24	129	59	x	x
6	150	10.50	267	x	x	21.00	533	12	305	11.00	279	1.00	25	161	73	x	x
8	200	11.50	292	x	x	25.00	635	14	356	13.50	343	1.13	29	277	126	x	x
10	250	13.00	330	x	x	29.00	737	16	406	16.00	406	1.19	30	415	188	x	x
12	300	14.00	356	x	x	34.50	876	18	457	19.00	483	1.25	32	631	287	x	x
14	350	15.00	381	x	x	40.38	1026	24	610	21.00	533	1.38	35	869	394	x	x
16	400	16.00	407	x	x	45.75	1162	24	610	23.50	597	1.44	37	1224	555	x	x

x Not available this size.

VISIT WWW.NIBCO.COM FOR CURRENT CHEM-GUIDE AND GALVANIC POTENTIAL IN PIPING SYSTEMS INFORMATION.

Visit our website for the most current information.



F-619
Flanged



T-619
Threaded



F-619-S0N
Flanged
With Square Op. Nut

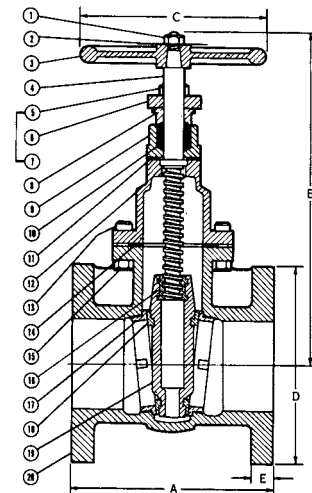

F-619
Flg x Flg

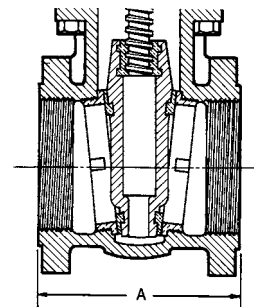

T-619
NPT x NPT

FREEZING WEATHER PRECAUTION: Subsequent to testing a piping system, valves should be left in an open position to allow complete drainage.

Position indicators available, see page 98.

◆ For detailed Operating Pressure, refer to Pressure Temperature Chart on page 114.