

Bronze Ball Valves

two-piece body • full port • bronze trim •
body with chrome plating • blowout-proof stem

600 PSI/41.4 bar non-shock cold working pressure ♦

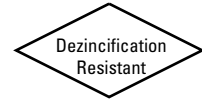

CONFORMS TO MSS SP-110

MATERIAL LIST

PART	SPECIFICATION
1. Handle Nut	Zinc Plated Steel
2. Handle	Zinc Plated Steel Clear Chromate Plastisol Coated
3. Threaded Pack Gland	Brass ASTM B 16 Alloy C36000
4. Packing	PTFE
5. Stem	Silicon Bronze ASTM B 371 Alloy C69300 or ASTM B 99 Alloy C65100
6. Thrust Washer	Reinforced PTFE
7. Ball	Brass ASTM B 124 Alloy C37700 or ASTM B16 Alloy C36000 EACH with Hard Chrome Plate
8. Seat Ring (2)	Reinforced PTFE
9. Body	Chrome Plated Bronze ASTM B 584 Alloy C84400
10. Body End Piece	Chrome Plated Bronze ASTM B 584 Alloy C84400

1/4" and 3/8" sizes have a 304 stainless steel grounding washer.



T-585-70-CP

Threaded

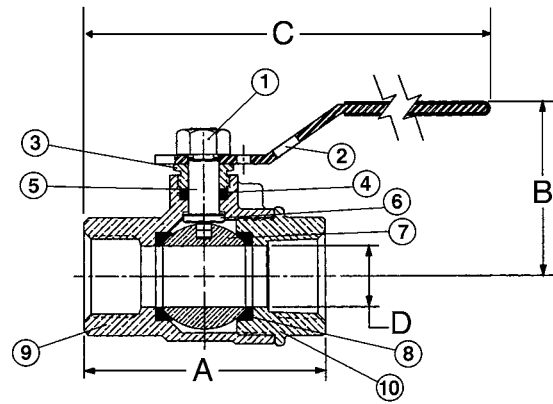

T-585-70-CP
NPT x NPT

DIMENSIONS—WEIGHTS—QUANTITIES

Size	Dimensions				T-585-70-CP	Master	
	A	B	C	D			
In. mm.	In. mm.	In. mm.	In. mm.	In. mm.	Lbs. Kg.	Ctn. Qty.	
1/4	8 2.00	51 1.75	44 5.00	127 5.00	.38 10	.45 .21	100
3/8	10 2.00	51 1.75	44 5.00	127 5.00	.38 10	.45 .20	100

Visit our website for the most current information.

♦ For detailed operating pressure, refer to pressure temperature chart on page 41.