



## Ventilation Fan Universal-Can (U-Can) Contractor Pack

- Ideal for residential construction (Single & Multi-Family) and Manufactured Homes
- UL approved for ceiling or wall mount - actually fits in 2 x 4 stud wall
- 3-3/8" Housing Depth – Lowest profile ENERGY STAR® fan available – fits anywhere!
- Wall Installation reduces cost by eliminating the need to incorporate a radiation damper when penetrating fire rated ceilings, making it perfect for Multi-Family applications
- L-shaped bracket simplifies installation and provides strong support
- UL Listed for tub/shower enclosure when GFCI protected
- Engineered to comply with ENERGY STAR® 4.0 requirement for increased efficiency (CFM/Watt)
- Can be used to comply with ASHRAE 62.2, LEED, IAP, California Title 24 and WA Ventilation Code
- Housing and motor/grille packaged separately
- Reduces risk of parts being lost or damaged onsite



**WhisperValue™**  
VENTILATION FAN

- Accommodates VS3 series **WhisperValue** models
- 60, 80 & 100 CFM
- 4" Oval Duct
- 4 Pack
- Optional 24 gauge, fire code rated 4" oval to 3" round duct adaptor, sold separately (model #FV-VS43R)
- 3 year warranty on parts



**WhisperValue Lite™**  
VENTILATION FAN

- Accommodates VS3 series **WhisperValue-Lite** models
- 80 & 100 CFM
- 4" Oval Duct
- Contemporary grille design with (2) 13W self-ballasted GU24 base CFL lamps – 4 Pack
- Optional 24 gauge, fire code rated 4" oval to 3" round duct adaptor, sold separately (model #FV-VS43R)
- 3 year warranty on parts, 3 year on CFLs





# U-Can Contractor Pack is the Contractor's Best Friend

Panasonic's *WhisperValue* and *WhisperValue-Lite* U-Can Contractor Packs are ideal for residential construction. The housing and motor/grille are packaged separately, which allows contractors to install the housing of the fan right after the framing of the structure. The motor and grille can then be installed at a later time when the construction is near complete. The U-Can Contractor Pack is also convenient because it allows contractors to store the components separately without the fear of parts getting lost or damaged on site. Another bonus of the Universal Can is the fact that it accommodates *WhisperValue* and *WhisperValue-Lite* models.



# WhisperValue™

VENTILATION FAN

4" Oval Duct 60, 80, & 100 CFM



### WhisperValue U-Can Contractor Pack

Universal Housing Can	Motor/Grille Assembly	Complete Fan Unit	Master Pack*
FV-05-10VSA3	FV-05VSB3	FV-05VS3	4
FV-05-10VSA3	FV-08VSB3	FV-08VS3	4
FV-05-10VSA3	FV-10VSB3E	FV-10VS3E	4

\* Must order in quantities of 4, shipment will contain 1 box with 4 units.



**Lowest profile,  
Actually fits  
in a 2 x 4!**

Fits in nearly every ceiling cavity

# WhisperValue Lite™

VENTILATION FAN

4" Oval Duct 80 & 100 CFM



### WhisperValue-Lite U-Can Contractor Pack

Universal Housing Can	Motor/Grille Assembly	Complete Fan Unit	Master Pack*
FV-08-10VSLA3	FV-08VSLB3	FV-08VSL3	4
FV-08-10VSLA3	FV-10VSLB3E	FV-10VSL3E	4

\* Must order in quantities of 4, shipment will contain 1 box with 4 units.



**Lowest profile,  
Actually fits  
in a 2 x 4!**

Fits in nearly every ceiling cavity

**3-3/8" housing depth.  
Actual depth of  
a 2 x 4 is 3-1/2"!**

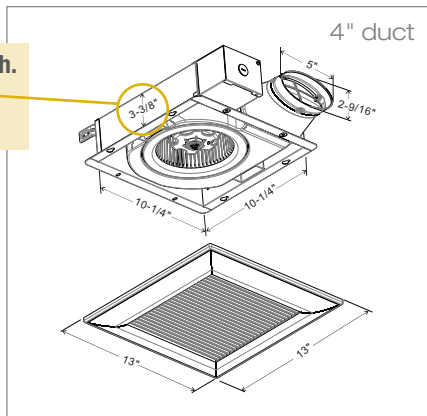

FV-05/08/10VS3E

**3-3/8" housing depth.  
Actual depth of  
a 2 x 4 is 3-1/2"!**

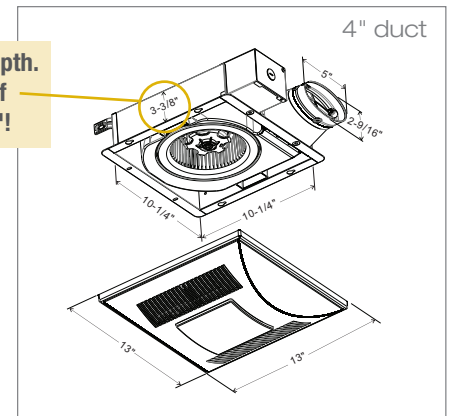

FV-08/10VSL3E

**FV-05VS3 4" Oval Duct**

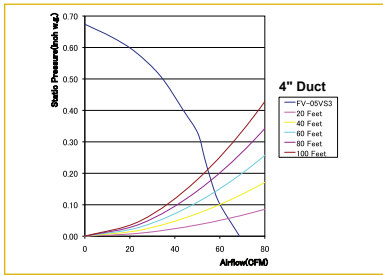

**FV-08VS3 4" Oval Duct**

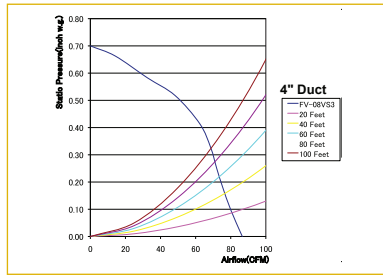

**FV-10VS3E 4" Oval Duct**

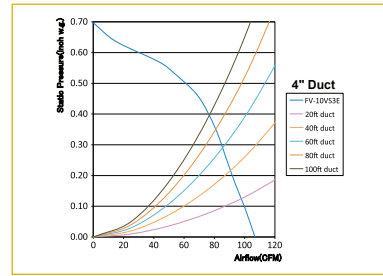

**FV-08VSL3 4" Oval Duct**

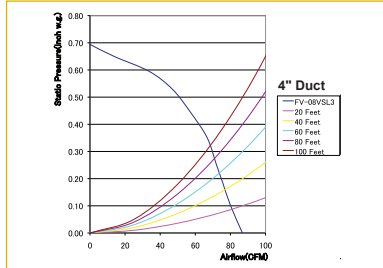

**FV-10VSL3E 4" Oval Duct**

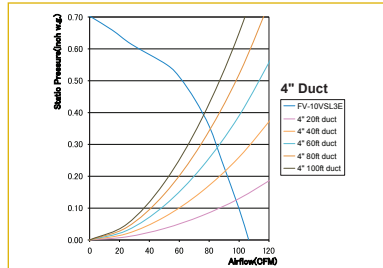

Specifications		WhisperValue 4" Oval Duct						WhisperValue-Lite 4" Oval Duct			
		FV-05VS3		FV-08VS3		FV-10VS3E		FV-08VSL3		FV-10VSL3E	
Characteristics (HVI tested data for 0.1" S.P.)	Static Pressure in inches w.g.	0.1	0.25	0.1	0.25	0.1	0.25	0.1	0.25	0.1	0.25
	Air Volume (CFM)	60	53	80	72	100	88	80	72	100	88
	Noise (sones)	0.4	1.0	0.6	0.9	1.0	1.3	0.5	0.7	1.0	1.1
	Power Consumption (watts)	15.9	16.3	21.2	21.5	26.7	26.4	22.5	22.9	27.3	27.0
	Energy Efficiency (CFM/Watt)	3.8	3.3	3.8	3.3	3.8	3.4	3.6	3.1	3.7	3.3
	Speed (RPM)	706	980	778	997	870	1049	825	1021	896	1059
	Current (amps)	0.13	0.14	0.18	0.18	0.23	0.23	0.19	0.19	0.23	0.22
	MAX. Current(amps)	0.15		0.21		0.23		0.21		0.24	
Power Rating (V/Hz)	120/60		120/60		120/60		120/60		120/60		
Specifications	Motor Type	AC		AC		AC		AC		AC	
	Type of Motor Bearing	Ball		Ball		Ball		Ball		Ball	
	Thermal Fuse Protection	Yes		Yes		Yes		Yes		Yes	
	Blower Wheel Type	Sirocco		Sirocco		Sirocco		Sirocco		Sirocco	
	ENERGY STAR Qualified	Yes		Yes		Yes		Yes		Yes	
Installation	Duct Diameter (Inches)	4 Oval		4 Oval		4 Oval		4 Oval		4 Oval	
	Mounting Opening (Inches sq.)	10-1/2		10-1/2		10-1/2		10-1/2		10-1/2	
	Grille Size (Inches sq.)	13		13		13		13		13	
Light Specifications	Lamp Watts	N/A		N/A		N/A		2 x 13W		2 x 13W	
	Lumens (lm)	N/A		N/A		N/A		998 lumens per lamp*		998 lumens per lamp*	
	Lumens Per Watt (LPW)	N/A		N/A		N/A		>70LPW*		>70LPW*	
	Color Rendering Index	N/A		N/A		N/A		>80		>80	
	Color Temperature (Kelvin)	N/A		N/A		N/A		3500K		3500K	
	Rated Life (hours)	N/A		N/A		N/A		10,000		10,000	
	Lamp Model #	N/A		N/A		N/A		MLS13GU35		MLS13GU35	
Type of Lamp Socket	N/A		N/A		N/A		GU24		GU24		
Night Light Specs	Night Light Watts	N/A		N/A		N/A		4W		4W	
Shipping	Gross Weight (lbs)	9.3		9.3		9.3		10.6		10.6	
Approved Code/Standard/ Regulation	UL tub/Shower Enclosure	Yes		Yes		Yes		Yes		Yes	
	Washington VIAQ Code	Yes		Yes		Yes		Yes		Yes	
	California Title 24 Compliant	Yes		Yes		Yes		Yes		Yes	
	Mfg in ISO 9001 Certified Facility	Yes		Yes		Yes		Yes		Yes	

\*As tested by an EPA recognized lab

\*\*Lamp contains mercury. Dispose of according to local, state and federal laws.

NOTE: 0.25" w.g. = Installed Performance



**Panasonic Eco Solutions of North America**  
**Eco Products Division**  
 Two Riverfront Plaza  
 Newark, NJ 07102  
[us.panasonic.com/ventfans](http://us.panasonic.com/ventfans)

**For Order Information**  
 PHONE: 866-292-7299  
 FAX: 888-553-0723  
[ventfans@us.panasonic.com](mailto:ventfans@us.panasonic.com)