

# SS-72-3

## Swanstone Bath Wall Kit



### Manufactured from Swanstone Solid Surface

Recommended for high-use traffic areas and commercial surfaces.

### FEATURES

- Will not mold or mildew, no grout to clean.
- Color and texture run all the way through and cannot wear away.
- Ideal for both remodeling projects and new construction.
- Heat resistant—walls can handle steamer units.
- Reinforced solid surface means color and texture run all the way through and cannot wear away.
- Unique glue-up wall system includes a single back panel, two side panels and two corner molding strips.
- Optional **TK-6072** trim kit available.
- Warranty: Limited Lifetime – Residential  
Limited 30-year – Commercial

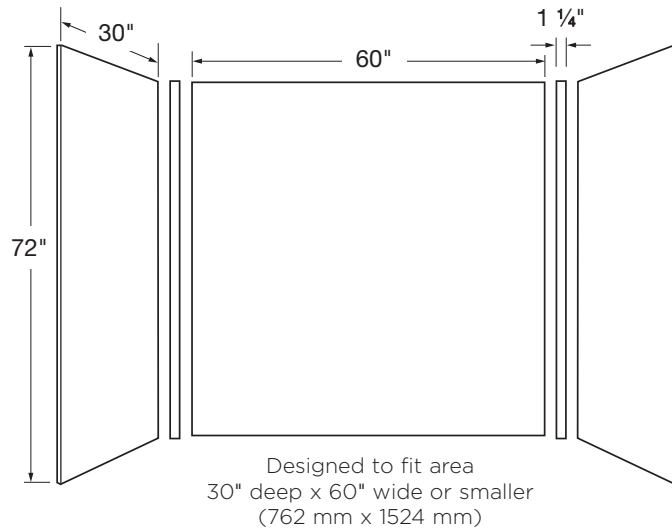

### SPECIFICATIONS

Model	Part	Ship Wt. Lb.	Carton Dims. In.	Cu. Ft.
SS-72-3	SS00723	165	78 x 66 x 4	11.92

**Kit Includes:** One flat back panel, two flat side panels, two corner moldings. Soap shelves and installation kit (**SS-29**) sold separately.

**Packaging:** Each kit is packed in a flat, rectangular carton.

### COLORS

#### Solid Colors:

- White (010)
- Bisque (018)
- Bone (037)

#### Aggregate Colors:

- Bermuda Sand (040)
- Black Galaxy (015)
- Carrara (221)
- Concrete Ash Gray (203)
- Concrete Birch (226)
- Concrete Charcoal Gray (209)
- Concrete Clay (212)
- Concrete Limestone (218)
- Concrete Sandstone (215)
- Ice (130)
- Tahiti White (011)

### ACCESSORIES

See page 56 for complete listing of all wall accessories.

### STANDARDS AND RATINGS

American Society of Testing and Materials (ASTM) E-84: Class A Flame Spread Rating

American National Standard Institute—ANSI Z124.6

International Association of Plumbing and Mechanical Officials (IAPMO)—Listed  
cUPC listed—Certified to CSA Test Standard B45.5 by IAPMO

Uniform Plumbing Code (UPC)

For a complete list of tests and results see the Technical Data Sheet.

### MAINTENANCE AND CLEANING INFORMATION

Clean regularly with common household liquid cleaners and rinse within five minutes of application. Occasional scrubbing with abrasive cleaners ensures that the original luster will be maintained. **Do not** use “leave on” cleaning products, such as automatic spray shower cleaners. Prolonged contact with harsh chemicals could have an adverse reaction over time and discolor surfaces.

**Do not** use cleaning agents that caution use on acrylic, polyester or plastics.

### SUPPORT DOCUMENTS

Installation instructions available at [swanstone.com](http://swanstone.com).

