

FEATURES

- Square vessel bathroom sink for above counter installation.
- Faucet deck with 1 center faucet hole drilling.
- Vitreous china.
- Concealed drain with vitreous china drain cover.
- 5 Year Limited Residential Warranty / 1 Year Commercial Warranty

COLOR

- White



TOILETS/LAVS

Specified Model

	MODEL NO.	DESCRIPTION	Length	Width	Height
ABOVE COUNTER LAVATORY					
<input type="checkbox"/>	TL-1651	Lavatory Vessel Bowl - 1 center hole	15 ³ / ₄ "	15 ³ / ₄ "	4 ³ / ₈ "

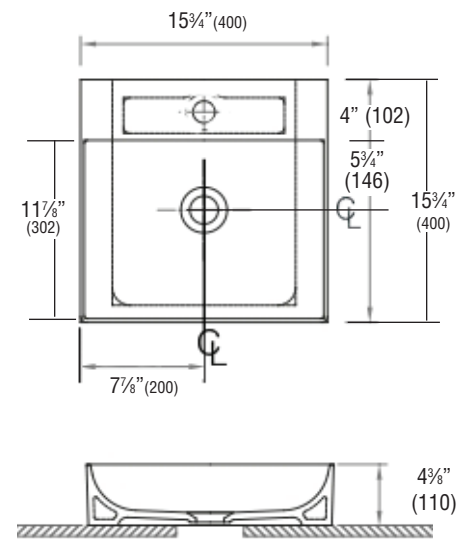

**Compliance Certifications -
Meets or Exceeds the Following Specifications**

- ASME A112.19.2M-1998
- Canadian Uniform Plumbing Code 2002
- UPC®

These measurements are subject to change or cancellation. No responsibility is assumed for use of superceded or voided pages.