

FEATURES

- Rectangular vessel bathroom sink for above counter installation.
- No faucet hole drillings.
- Vitreous china.
- Concealed drain with vitreous china drain cover.
- Designed for use with vessel or wall-mount faucets (not included).
- 5 Year Limited Residential Warranty / 1 Year Commercial Warranty

COLOR

- White



TOILETS/LAVS

Specified Model

	MODEL NO.	DESCRIPTION	Length	Width	Height
ABOVE COUNTER LAVATORY					
☐	TL-1610	Lavatory Vessel Bowl	16½"	10⅝"	4⅜"

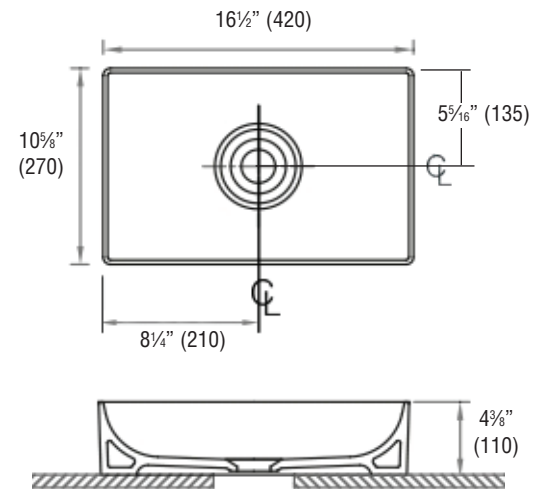

**Compliance Certifications -
Meets or Exceeds the Following Specifications**

- ASME A112.19.2M-1998
- Canadian Uniform Plumbing Code 2002
- UPC®

These measurements are subject to change or cancellation. No responsibility is assumed for use of superceded or voided pages.