

# Installation & Operation Manual

## NCB-E Condensing Combi-Boilers

Model | NCB-150E  
NCB-180E  
NCB-210E  
NCB-240E



Keep this manual near this boiler for future reference whenever maintenance or service is required.

\* The wetted surface of this product contacted by consumable water contains less than one quarter of one percent (0.25%) of lead by weight.



### WARNING

If the information in these instructions is not followed exactly, a fire or explosion may result, causing property damage, personal injury or death.

Do not store or use gasoline or other flammable vapors and liquids in the vicinity of this or any other appliance.

#### What to do if you smell gas

- ☐ Do not try to light any appliance.
- ☐ Do not touch any electrical switch; do not use any phone in your building.
- ☐ Immediately call your gas supplier from a neighbor's phone. Follow the gas supplier's instructions.
- ☐ If you cannot reach your gas supplier, call the fire department.

Installation and service must be performed by a qualified installer, service agency or the gas supplier.

The installation must conform with local codes or, in the absence of local codes, the National Fuel Gas Code, ANSI Z223.1/NFPA 54 and/or CSA B149.1, Natural Gas and Propane Installation Code.

## Requirements for the State of Massachusetts

### NOTICE BEFORE INSTALLATION

This appliance must be installed by a licensed plumber or gas fitter in accordance with the Massachusetts Plumbing and Fuel Gas Code [808 CMR Sections 5.00](#) and [5.00](#).

IMPORTANT: In the State of Massachusetts ([808 CMR 5.00](#) & [5.00](#))

For all side wall horizontally vented gas fueled equipment installed in every dwelling, building or structure used in whole or in part for residential purposes, including those owned or operated by the Commonwealth and where the side wall exhaust vent termination is less than seven (7) feet above finished grade in the area of the venting, including but not limited to decks and porches, the following requirements shall be satisfied:

- [808 CMR 5.09](#) **INSTALLATION OF CARBON MONOXIDE DETECTORS.** No installation or replacement of a vented gas appliance shall be permitted unless a battery powered or electrically hard wired carbon monoxide detector is present on the same floor as the appliance or on the next adjacent floor when the appliance is located in a crawl space unless the appliance is located in a detached, uninhabitable garage. For all residential dwellings, a carbon monoxide detector must also be present on each habitable level of the dwelling. These requirements shall not be deemed to waive any additional requirements imposed by M.G.L. c. [80B § 6F\(1\)](#).
- [808 CMR 5.09](#) **APPROVED CARBON MONOXIDE DETECTORS.** Each carbon monoxide detector as required in accordance with the above provisions shall comply with NFPA [720](#) and be ANSI/UL [703](#) listed and IAS certified.
3. **SIGNAGE.** Whenever any through-the-wall vent is installed less than seven feet above the finished grade, a metal or plastic identification plate shall be permanently mounted to the exterior of the building at a minimum height of eight feet above grade directly in line with the exhaust vent terminal. The sign shall read, in print size no less than 0.5 inches in size, "GAS VENT DIRECTLY BELOW. KEEP CLEAR OF ALL OBSTRUCTIONS".
- [808 CMR 5.09](#) **INSPECTION.** The state or local gas inspector of the side wall horizontally vented gas fueled equipment shall not approve the installation unless, upon inspection, the inspector observes carbon monoxide detectors and signage installed in accordance with the provisions of [808 CMR 5.09](#) and [5.09](#).

# Contents

---

Safety Information	4	7. Setting the DIP Switches	48
1. About the Boiler	7	7.1 PCB DIP Switches	48
1.1 Items Included	7	7.2 Front Panel Dip Switches	49
1.2 Accessories	7	8. Connecting the Power Supply	50
1.3 Specifications	8	9. Installation Check list	51
1.4 Components	10	10. Operating the Boiler	54
1.5 Dimensions	11	10.1 Turning the Boiler On or Off	54
1.6 Rating Plate	13	10.2 Adjusting the Temperature	55
2. Installing the Boiler	14	10.3 Viewing Basic Information	55
2.1 Choosing an Installation Location	14	10.4 Setting the Operation Mode	56
2.2 Mounting the Boiler to the Wall	16	10.5 Setting the Parameters	56
3. Installing the System Piping	17	10.6 Resetting the Boiler	63
3.1 Installing a Space Heating System	17	11. Appendixes	64
3.2 Installing a Domestic Hot Water (DHW) System	19	11.1 Gas Conversion	64
3.3 Connecting the Condensate Drain	23	11.2 Wiring Diagram	70
3.4 System Fill Connection	26	11.3 Ladder Diagram	71
3.5 Testing the Water System	27	11.4 Component Assembly Diagrams and Parts Lists	71
3.6 Examples of System Applications	27	11.5 Outdoor Temperature Sensor (Optional)	80
4. Installing a Cascading System	32	11.6 Outdoor Reset Control (Available with Optional Outdoor Temperature Sensor)	80
4.1 Connecting Water Supplies	32		
4.2 Connecting the Communication Cables	33		
4.3 Configuring the Communication Settings	33		
5. Connecting the Gas Supply	35		
5.1 Gas Pipe Sizing Tables	37		
5.2 Measuring the Inlet Gas Pressure	38		
6. Venting the Boiler	40		
6.1 Selecting a Vent Type	40		
6.2 Selecting Vent Pipe Materials	41		
6.3 Measuring Vent Length	45		

# Safety Information

The following safety symbols are used in this manual. Read and follow all safety instructions in this manual precisely to avoid unsafe operating conditions, fire, explosion, property damage, personal injury, or death.



**DANGER**

Indicates an imminently hazardous situation which, if not avoided, could result in severe injury or death.



**WARNING**

Indicates a potentially hazardous situation which, if not avoided, could result in injury or death.



**CAUTION**

Indicates a potentially hazardous situation which, if not avoided, could result in property damage.



**DANGER**



If you smell gas:

- ❑ Do not try to light any appliance.
- ❑ Do not touch any electrical switches or use landline phones.
- ❑ From a neighbor's phone, call your gas provider and follow their instructions.
- ❑ If you cannot reach your gas provider, call the fire department.
- ❑ Do not return to your home until authorized by your gas supplier or the fire department.

Do not use or store flammable products, such as gasoline, solvents, or adhesives in the same room or area as the boiler.

- ❑ The boiler has a main burner flame that can turn on at any time and can ignite flammable vapors. Vapors from flammable liquids can explode and catch fire, causing death or severe burns.
- ❑ Vapors cannot be seen and are heavier than air. They can travel long distances along the ground and can be carried from other rooms to the boiler's main burner flame by air current.
- ❑ Keep all flammable products far away from the boiler and store them in approved containers. Keep the containers closed tightly and out of the reach of children and pets.



## WARNING

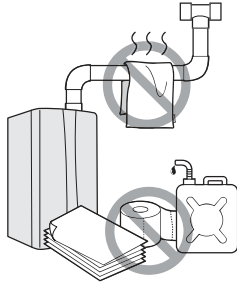

- ❑ Do not store or use gasoline or other flammable liquids near this boiler.  
Doing so may result in fire or explosion.
- ❑ Do not place combustibles, such as newspapers or laundry, near the boiler or venting system.  
Doing so may result in a fire.
- ❑ Do not place or use hair sprays, spray paints, or any other compressed gases near the boiler or venting system, including the vent termination.  
Doing so may result in fire or explosion.
- ❑ Do not remove the front cover unless the power to the boiler is turned off or disconnected.  
Failure to do so may result in electric shock.
- ❑ Do not operate the boiler with the front cover opened.  
Doing so may result in fire or carbon monoxide (CO) poisoning, which may result in property damage, personal injury, or death.
- ❑ Do not operate this boiler without proper venting.  
Doing so may result in fire or carbon monoxide (CO) poisoning, which may result in property damage, personal injury, or death.
- ❑ Do not touch the power cord or internal components of the boiler with wet hands.  
Doing so may result in electric shock.



## CAUTION

- ❑ Do not turn on the boiler unless the water and gas supplies are fully opened.  
Doing so may damage the boiler.
- ❑ Do not turn on the water if the cold water supply shut-off valve is closed.  
Doing so may damage the boiler.
- ❑ Do not use this boiler for anything other than its intended purpose, as described in this manual.
- ❑ When servicing the controls, label all wires prior to disconnecting them.  
Failure to do so may result in wiring errors, which can lead to improper or dangerous operation. Verify proper operation after servicing.
- ❑ Do not use unapproved replacement or accessory parts.  
Doing so may result in improper or dangerous operation and will void the manufacturer's warranty.
- ❑ Do not place anything in or around the vent terminals, such as a clothes line, that could obstruct the air flow in or out of the boiler.
- ❑ This boiler has been approved for use in the USA and Canada only.  
Using the boiler in any other country will void the manufacturer's warranty.

**! DANGER**



To prevent burns:

- ▣ Use the lowest operating temperature setting necessary to provide comfortably-hot water.
- ▣ If your household has children or elderly or disabled residents, consider using a lower temperature setting.
- ▣ Read all the instructions in this manual carefully before changing the temperature setting.
- ▣ Feel the water before using it on children, the elderly, or the disabled.
- ▣ If it is necessary to set the water temperature above 115°F (51°C), consider installing a thermostatically-controlled mixing valve or temperature-limiting valve. Contact a licensed plumber or your local plumbing authority for more information.

**! DANGER**







This boiler's water temperature is set to 110°F (49°C) at the factory for your safety and comfort. Increasing the temperature increases the risk of accidental scalding. Water temperatures at or above 115°F (51°C) can cause instant scalding, severe burns, or death. Before you decide to change the temperature setting, read the following charts carefully.

Water Temperature	Time in which a young child can suffer a full thickness (3rd degree) burn
160°F (70°C)	Less than 1 second
140°F (60°C)	1 second
130°F (55°C)	10 seconds
110°F (49°C)	5 minutes
100°F (37°C)	very low scald risk

# 1. About the Boiler

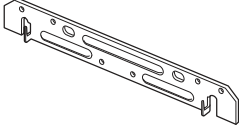
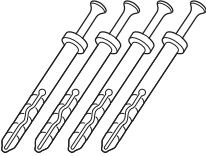

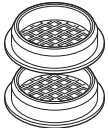
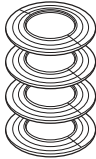
## 1.1 Items Included

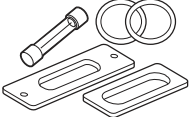
When you open the box, you will find the following items with the boiler. Check the box for each of the following items before installing the boiler.

				
Installation & Operation Manual, User's Information Manual	Quick Installation Manual	Wall Mounting Bracket	Tapping Screws & Anchors	Conversion Kit
				
iVent Vent Termination Caps	iVent Wall Flanges	Pressure Relief Valve, Heating	Flow Restrictors	Spare Parts

## 1.2 Accessories

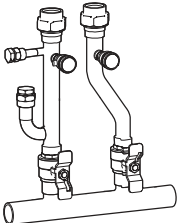
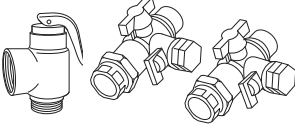
The following optional accessories are available for the boiler:

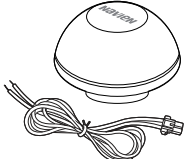
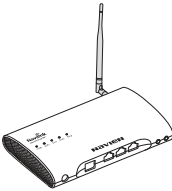
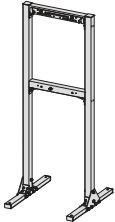
			
Navien Manifold System	Plumb Easy Valve Set (Pressure Relief Valve, DHW)	Condensate Neutralizer	Outdoor Temperature Sensor with Cable
			
Navi-Link (Wi-Fi Control System)	Ready-Link Pack		

## 1.3 Specifications

The following tables list the specifications for the boiler. Additional specifications about water, gas, electric, and air supplies (venting) appear in the Installation section.

### Space Heating Specifications

Navien Combination Boiler Space Heating Ratings					 Other Specifications		
Model Number <sup>1)</sup>	Heating Input, MBH		Heating Capacity <sup>2)</sup> , MBH	Net AHRI Rating Water <sup>3)</sup> , MBH	AFUE <sup>2)</sup> , %	Water Pressure	Water Connection size (Supply, Return)
	Min	Max					
NCB-150E	13	60	56	9	95	130 psi	1 1/2" NPT
NCB-180E	13	80	75	65	95		
NCB-210E	8	100	91	81	95		
NCB-240E	8	110	113	97	95		

**Note**

<sup>1)</sup> Ratings are the same for natural gas models converted to propane use.

<sup>2)</sup> Based on U.S. Department of Energy (DOE) test procedures.

3. The net AHRI water ratings shown are based on a piping and pickup allowance of 1.5. Consult Navien before selecting a boiler for installations having unusual piping and pickup requirements, such as intermittent system operation, extensive piping system, etc.

### Domestic Hot Water Specifications

Item	NCB-150E	NCB-180E	NCB-210E	NCB-240E
Input Ratings	Min	11,000 BTU/H	11,000 BTU/H	8,000 BTU/H
	Max	110,000 BTU/H	150,000 BTU/H	80,000 BTU/H
Water Pressure	15-150 psi			
Minimum Flow Rate	0.5 GPM (19 L/m)			
Flow Rate 77°F (25°C) Temp. Rise	8 GPM	3.8 GPM	10 GPM	15 GPM
DHW Supply Connection Size	3/4" NPT			
Cold Water Input Connection Size	3/4" NPT			



General Specifications

Item	NCB-150E	NCB-180E	NCB-210E	NCB-240E
Dimensions	37 in (W) x 36 in (H) x 14 in (D)			
Weight	66 lbs (30 kg)	77 lbs (35 kg)	87 lbs (38 kg)	87 lbs (38 kg)
Installation Type	Indoor Wall-Hung			
Venting Type	Forced Draft Direct Vent			
Ignition	Electronic Ignition			
Natural Gas Supply Pressure (from source)	3.5 in-10.5 in WC			
Propane Gas Supply Pressure (from source)	8.0 in-10.5 in WC			
Natural Gas Manifold Pressure (min/max)	-0.09 in WC/ -0.3 in WC	-0.07 in WC/ -0.66 in WC	-0.05 in WC/ -0.36 in WC	-0.06 in WC/ -0.16 in WC
Propane Gas Manifold Pressure (min/max)	-0.0 in WC/ -0.30 in WC	-0.07 in WC/ -0.66 in WC	-0.1 in WC/ -0.66 in WC	-0.03 in WC/ -0.98 in WC
Gas Connection Size	3/4 in NPT			
Power Supply	Main Supply	120 V AC, 60Hz		
	Maximum Power Consumption	100 W (max 1 A)		
Materials	Casing	Cold-rolled carbon steel		
	Heat Exchangers	Primary Heat Exchanger: Stainless Steel Secondary Heat Exchanger: Stainless Steel Domestic Water Heat Exchanger: Stainless Steel		
Venting	Exhaust	1 in or 3 in PVC, CPVC, Polypropylene 1 in or 3 in Special Gas Vent Type BH (Class III, A/B/C)		
	Intake	1 in or 3 in PVC, CPVC, Polypropylene 1 in or 3 in Special Gas Vent Type BH (Class III, A/B/C)		
	Vent Clearances	0 in to combustibles		
Safety Devices	Flame Rtd, APS, Gas Valve Operation Detector, Ignition Operation Detector, Water Temperature High Limit Switch, Exhaust Temperature High Limit Sensor			

**Note** This unit may be installed at elevations up to 10,000 ft (3,078 m) for use with Natural Gas, and up to 1,500 ft (457 m) for use with Propane.

Temperature Setting Range

Item	Temperature Setting Range	Remarks
DHW	89°F-140°F (30°C-60°C)	
Space Heating	Supply 110°F-130°F (43.5°C-83°C)	Finned Tube Baseboard (Default)
	Return 101°F-147°F (38°C-63.5°C)	

**Note** For more information about space heating temperature setting range, refer to “Types of Heat Load” on page 58.

## 1.4 Components

The following diagram shows the key components of the boiler. Component assembly diagrams and particular parts lists are included in the Appendixes.

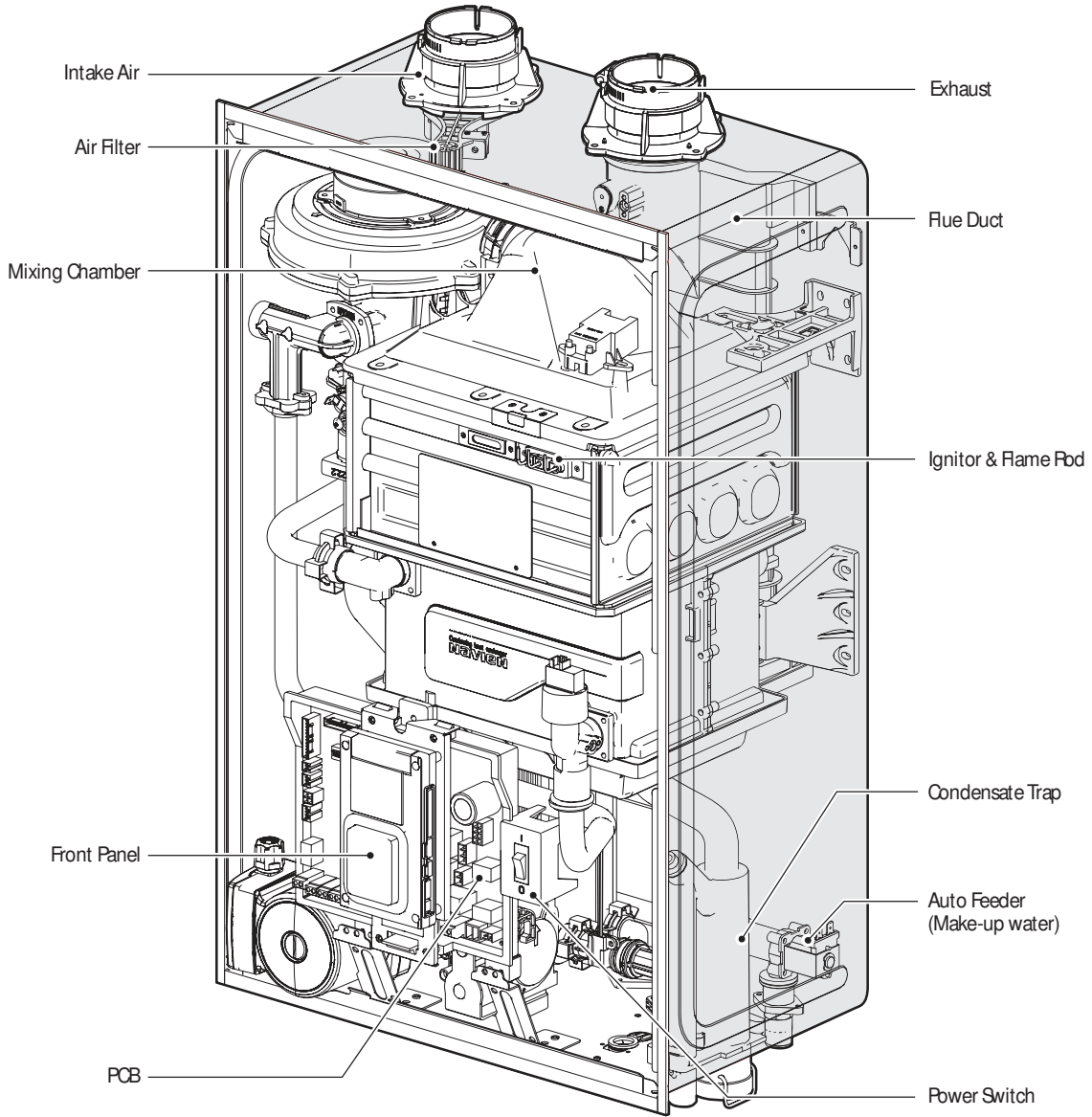

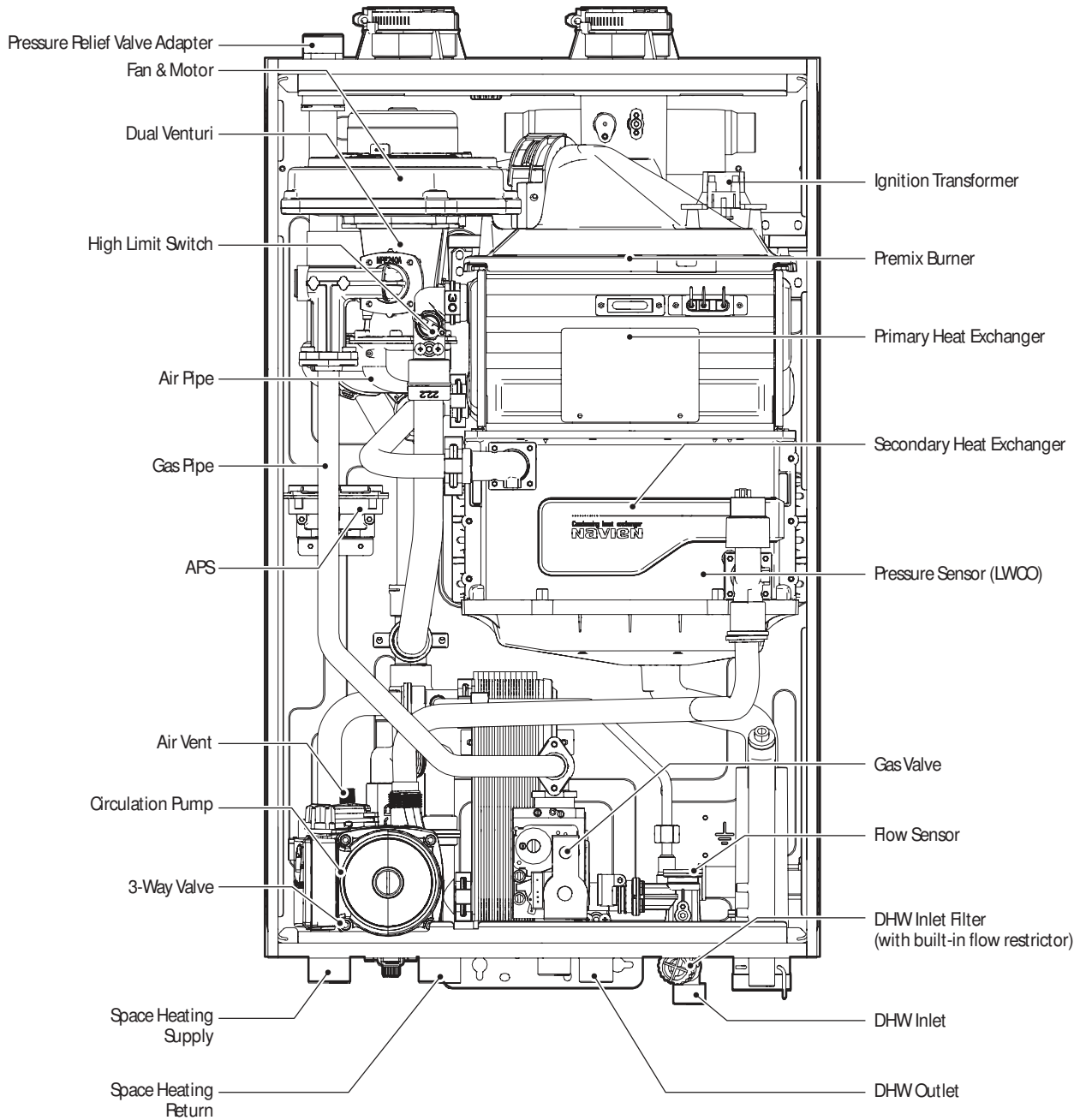

## 1.5 Dimensions

The following diagrams show the dimensions of the boiler and the table lists the supply connections.

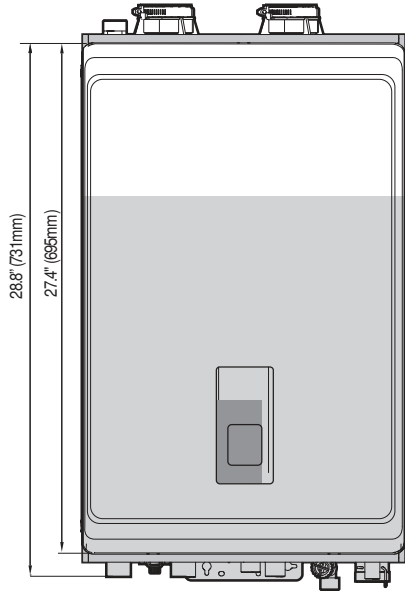

### Supply Connections

	Description	Diameter
A	Pressure Relief Valve Adapter	3/4 in
B	Air Intake	1 1/2 in
C	Exhaust Gas Vent	1 1/2 in
D	Space Heating Supply	1 1/2 in
E	Space Heating Return	1 1/2 in
F	Hot Water Outlet (DHW)	3/4 in
G	Gas Supply Inlet	3/4 in
H	Cold Water Inlet (DHW)	3/4 in
I	Condensate Outlet	1/2 in
J	Auto Feeder Inlet (Make-up Water)	1/2 in

### Overhead View

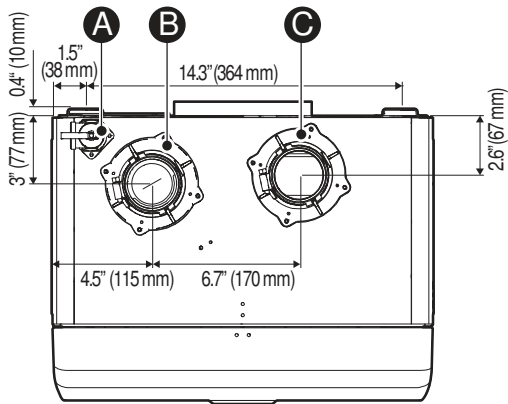



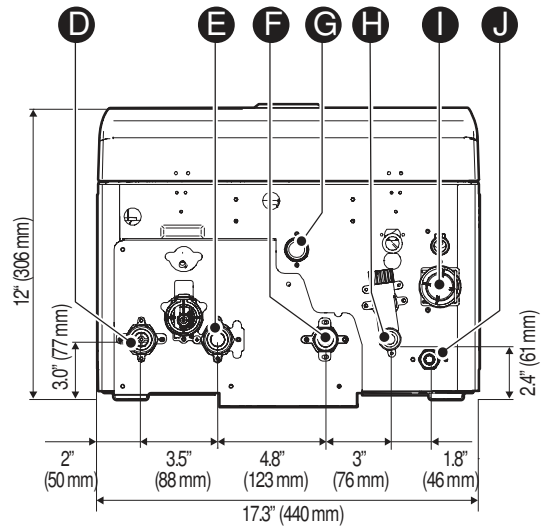

### Supply Connections



## 1.6 Rating Plate

The Navien NCB-E boilers come from the factory configured for use with Natural Gas (NG). Before starting the installation, check the rating plate located on the side of the boiler to ensure that the boiler matches the gas type, gas pressure, water pressure, and electrical supply available in the installation location. If the boiler does not match each of these ratings, do not install the boiler. If conversion to Propane Gas is required, the included gas conversion kit must be used. Refer to “ Gas Conversion” for details.

### Rating Plate, \*Plaque Signalétique

Combination Boiler *Chaudière combinaison		 	
Navien, Inc.		 	
20 Goodyear, Irvine, CA 92618			
Tel: 1-800-519-8794			
Direct vent indoor installation, *Évacuation directe installation intérieure			
Model No., *Numéro de modèle	NCB-240E	Type of Gas, *Type de gaz	NG
Max. Input Rating (DHW), *Entrée GPL max.	199,900 Btu/h	Min. Input Rating, *Débit calorifique max.	18,000 Btu/h
Max. Input Rating (Heating), *Entrée GPL max.	120,000 Btu/h	Heating Capacity, *Capacité de chauffage	112,000 Btu/h
Category of boiler, *Catégorie de chaudière	Category IV	Net AHRI Rating, *Régime de AHRI	97,000 Btu/h
Max. Inlet Gas Pressure, *Pression max. de gaz d'entrée	10.5 Inches W.C. *pouces W.C.	Min. Inlet Gas Pressure, *Pression min. de gaz d'entrée	3.5 Inches W.C. *pouces W.C.
Manifold Pressure, *Pression d'admission	-1.20 Inches W.C. *pouces W.C.	Electrical Rating, *Régime nominal électrique	AC *c.a. 120 Volts 60Hz Use less than 2 Amp, *Utilise moins de 2A
Minimum relief valve capacity, *Capacité minimum soupape.	189 lbs/hr		ANSI Z21.13b-2014 · CSA 4.9b-2014

Orifices necessary for LP conversion are provided. \*Les injecteurs nécessaires à la conversion au GPL sont fournis.

Failure to use the correct gas can cause problems which can result in death, serious injury or property damage. \*Le fait de ne pas utiliser le bon gaz peut causer des problèmes qui peuvent mener à la mort, causer des blessures graves ou endommager la propriété.

Consult your installation manual for more information. \*Consultez votre manuel d'installation pour plus d'information.

This appliance is certified for use at altitudes up to 4,500 ft (1,370 m) in accordance to the latest CAN/CGA 2.17-High Altitude Installation procedures at normal manifold pressure. For installation instructions at altitudes higher than 4,500 ft, please contact Navien. \*Cet appareil est certifié pour une utilisation à des altitudes de 0 à 4,500 pieds (1,370 m) conformément aux toutes les procédures d'installation à haute altitude CAN/CGA 2.17 à une pression normale. Pour les installations à élévations en haut de 4,500 pieds, appeler le bureau de Navien.

This appliance must be installed in accordance with local codes or in the absence of local codes, the most recent edition of National Fuel Gas Code, ANSI Z223. 1, in Canada use CAN/CGA B149. 1 or 2 installation codes for Gas Burning Appliances.

\*Cet appareil doit être installé conformément aux codes locaux, ou s'il n'y a pas de codes locaux, la plus récente version du National Fuel Gas Code des E.-U., ANSI Z223. 1, au Canada utilisez les codes d'installation CAN/CGA B149. 1 ou 2 pour les appareils à gaz.

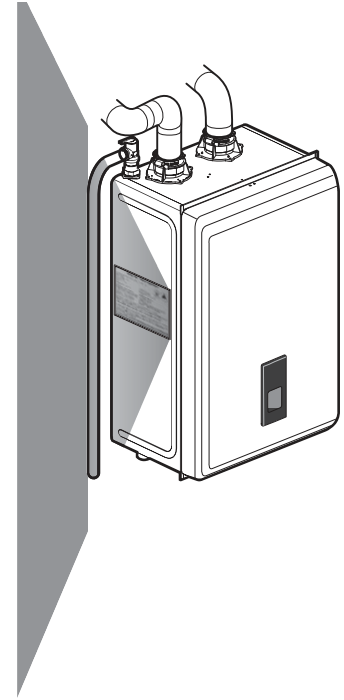

**FOR YOUR SAFETY \*POUR VOTRE SÉCURITÉ**

Do not store or use gasoline or other flammable vapors and liquids in the vicinity of this or any other gas appliances. \*Ne rangez pas et n'utilisez pas d'essence ou d'autres liquides ou vapeurs inflammables près de cet appareil ou de tout autre appareil électroménager.



### WARNING

Ensure that the gas type and power source specifications match what is listed on the rating plate. Using a different gas type will cause abnormal combustion and boiler malfunction. Using abnormally high or low AC voltage may cause abnormal operation, and may reduce the life expectancy of the product.

This appliance complies with the requirements of SCAQMD Rule  for NOx emissions of  g/Jor  ppm at 3% O<sub>2</sub>

## 2. Installing the Boiler

### 2.1 Choosing an Installation Location

When choosing an installation location, you must ensure that the location provides adequate clearance for the boiler, adequate venting and drainage options, and sufficient access to gas, water, and electrical supplies. Carefully consider the following factors when choosing an installation location:

#### Compliance Requirements

- ☐ Local, state, provincial, and national codes, laws, regulations, and ordinances.
- ☐ National Fuel Gas Code, ANSI Z39.31 latest edition.
- ☐ Standard for Controls and Safety Devices for Automatically Fired Boilers, ANSI/ASME CSD-1 when required.
- ☐ National Electrical Code.
- ☐ For Canada only: B781 Installation Code, CSA C147 Canadian Electrical Code Part 1 and any local codes.

#### Access to Utilities

- ☐ Water – the installation location should be near where the domestic water supply enters the building.
- ☐ Gas – the installation location should be near where the gas supply enters the building.
- ☐ Electricity – the installation location should be near where the electrical supply enters the building.

#### Humidity and Contact with Water

When installing the boiler, avoid places with excessive humidity. The boiler has electric gas ignition components. Water spray or droppings can get inside the boiler and damage the ignition system. The boiler must be installed in a way to ensure that the gas ignition system components are protected from water (dripping, spraying, rain, etc.) during operation and service.

#### Adequate Drainage

The boiler produces a significant amount of condensate during operation. The boiler should be located near a suitable drain and where damage from a possible leak will be minimal. Installing the boiler in a location without a drain will void the warranty and Navien will not be responsible for water damages that occur as a result. For more information about condensate drainage, refer to “3.3 Connecting the Condensate Drain” on page 3.

The boiler must be located in an area where leakage of the unit or connections will not result in damage to the area adjacent to the appliance or to lower floors of the structure. When such locations cannot be found, installation of an adequately drained drain pan under the boiler is highly recommended. When installing the drain pan, ensure that the installation does not restrict combustion air flow.

#### Adequate Venting and Ventilation

Select a location that requires minimal venting. Consider venting restrictions caused by windows, doors, air intakes, gas meters, foliage, and other buildings. For more information about venting, refer to “6. Venting the Boiler” on page 6.

To ensure adequate venting and ventilation, follow these guidelines:

- ☐ Maintain proper clearances from any openings in the building.
- ☐ Install the boiler with a minimum clearance of 300 mm (300 mm) above an exterior grade or as required by local codes.
- ☐ Maintain a minimum clearance of 1 ft (300 mm) from heating and cooling vents.
- ☐ Do not enclose the vent termination.
- ☐ Install the exhaust vent in an area that is free from any obstructions, where the exhaust will not accumulate.
- ☐ Do not install the boiler where moisture from the exhaust may discolor or damage walls.
- ☐ Do not install the boiler in bathrooms, bedrooms, or any other occupied rooms that are normally kept closed or not adequately ventilated.

#### Proximity to Fixtures and Appliances

Install the boiler near fixtures that deliver or use hot water, such as bathroom, kitchen, and laundry room faucets. Select a location that minimizes the water piping required between major fixtures. If the distances are long or if the user requires “instant” hot water, installation of a recirculation line which circulates domestic hot water back to the boiler from the furthest fixture is recommended. Insulate as much of the hot water supply and recirculation lines as possible. For more information about the water supply, refer to “3.3 Installing a Domestic Hot Water (DHW) System” on page 3.

Adequate installation clearances

**! CAUTION**

Do not install the boiler on carpeting.

Install the boiler in an area that allows for service and maintenance access to utility connections, piping, filters, and traps. Based on the installation location, ensure that the following clearances are maintained:

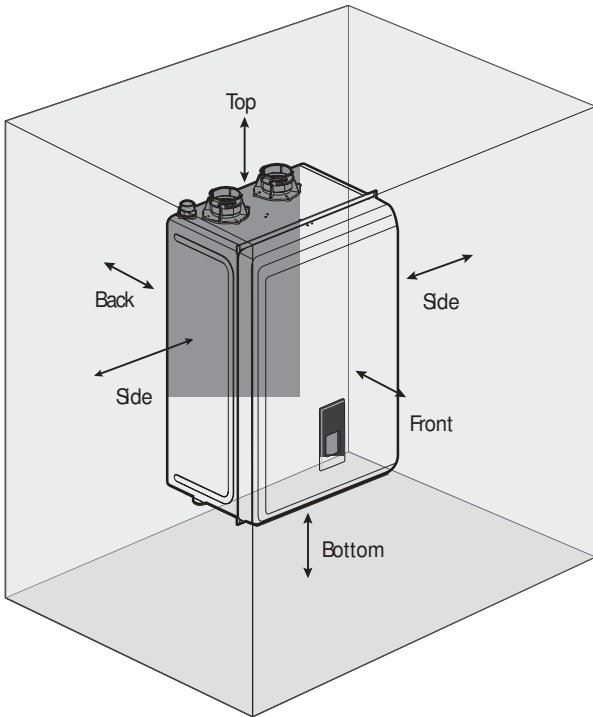

Clearance from:	Indoor Installation
Top	9 in (229 mm) minimum
Back	0.5 in (13 mm) minimum
Front	1 in (25 mm) minimum
Sides	3 in (76 mm) minimum
Bottom	1 in (300 mm) minimum

Clean, debris and chemical-free combustion air

- ❑ Do not install the boiler in areas where dust and debris may accumulate or where hair sprays, spray detergents, chlorine, or similar chemicals are used.
- ❑ Do not install the boiler in areas where gasoline or other flammables are used or stored.
- ❑ Ensure that combustible materials are stored away from the boiler and that hanging laundry or similar items do not obstruct access to the boiler or its venting.

High Elevation Installations

This boiler may be installed at elevations up to 6,000 ft (3,078 m) for use with natural gas (NG), and up to 5,000 ft (1,537 m) for use with liquefied petroleum (LP). Refer to "7. Setting the DIP Switches" on page 8 for the appropriate altitude setting.

**Note** Above 6,000 ft (1,800 m), the boiler will derate by 2% for each 1,000 ft (300 m) of altitude gain.

## 2.2 Mounting the Boiler to the Wall

Navien NCB-Eboilers come with an upper mounting bracket that is pre-drilled at  $\frac{1}{8}$  in (3 mm) on center for easy installation on standard wall studs. If the strength of the wall is insufficient or if the framing is non-standard or uneven, reinforce the area before installing the boiler. Avoid installation on common walls as the unit will make some operational noises while it is running.

To mount the boiler to the wall:

1. Affix the bracket securely to the wall and ensure that it is level and that it can support the weight of the boiler.
2. Align the grooves on the back of the boiler with the tongues on the mounting bracket and hang the boiler on the bracket. When mounted with the mounting bracket, the boiler will have a  $\frac{5}{8}$  in (16 mm) clearance from the back of the wall.

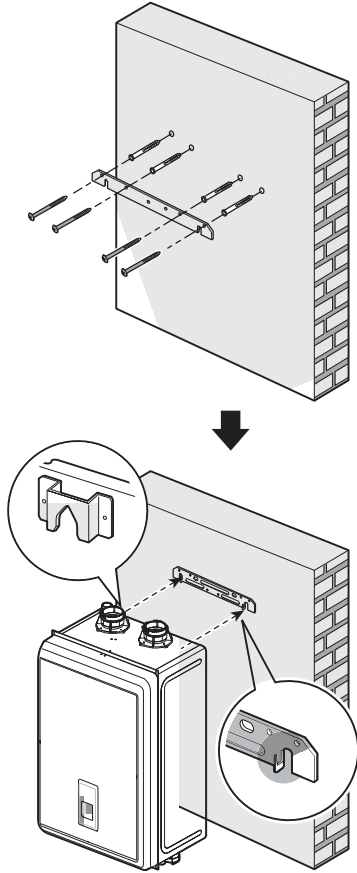

### WARNING

1. The boiler is heavy. Always lift the unit with assistance. Be careful not to drop the boiler while lifting or handling it to avoid bodily injury or damage to the unit.
2. Do not rest the boiler on the bottom end after removing it from the shipping carton. Doing so may result in excessive pressure on protruding pipes and cause product damage. If you must put the boiler down, lay it on its back or put it inside the protective shipping base.

### CAUTION

Do not mount the boiler to dry wall that has not been reinforced.



### 3. Installing the System Piping

Prior to connecting plumbing to the boiler, flush the entire system to ensure it is free of sediment, flux, solder, scale, debris or other impurities that may be harmful to the system and boiler. During the assembly of the heating system, it is important to keep the inside of the piping free of any debris including construction and copper dust, sand and dirt.

For retrofits, all system piping including radiators, must be cleaned of all build-up including sludge and scale. All systems, old and new, must be cleaned to remove flux, grease and carbon residue. Navien recommends cleaning the boiler system with cleaning products specially formulated for boiler systems. For retrofit applications with heavy limescale and sludge deposits, a heavier duty cleaner may be required. For information on performing the cleaning, follow the instructions included with the boiler system cleaner products.



#### WARNING

Failure to rid the heating system of the contaminants listed above will void your warranty and may result in premature heat exchanger failure and property damage.

### 3.1 Installing a Space Heating System

The primary and secondary heat exchangers of the Navien NCB-E boiler are designed to attain the highest level of heat transfer in a compact design. To accomplish this, the heating water flows through a series of tubes (secondary heat exchanger) and finned tubes (primary heat exchanger), designed to maximize the heat transfer area. To maintain the efficient and reliable operation of the heat exchangers, and to avoid heat exchanger failure, it is critical to ensure the rules and guidelines in this section are followed.



#### CAUTION

Failure to follow the instructions provided in this section will void the warranty and may result in property damage, fire, serious injury or death.

#### 3.1.1 Guidelines for a Space Heating Installation

Read and follow the guidelines listed below to ensure safe and proper installation of a boiler heating system.

##### Freeze Protection for a Space Heating System

- ❑ Freeze protection products may be used for the space heating system. Freeze protection for new or existing systems requires specially formulated glycol, which contains inhibitors to prevent the glycol from attacking the metallic system components.
- ❑ Before using freeze protection products, ensure that system fluid contains proper glycol concentration and the inhibitor level is appropriate. Navien recommends against exceeding a 35% concentration of glycol.
- ❑ When using the freeze protection products, the system must be tested at least once a year, and as recommended by the manufacturer of the glycol solution.
- ❑ When using the freeze protection products, allowance should be made for expansion of the glycol solution.
- ❑ Freeze damage is not covered by the warranty.



#### WARNING

For systems requiring freeze protection, use only inhibited propylene glycol, specially formulated for hydronic heating systems; use of other types of antifreeze may be harmful to the system and will void the warranty.

##### System Pressure

- ❑ The Navien NCB-E boiler is intended solely for use in pressurized closed loop heating systems operating with 130 psi water pressure at the boiler outlet. To obtain the minimum system design pressure, follow the piping diagrams illustrated in this section.
- ❑ The Navien NCB-E boiler's space heating system is not approved for operation in an "open system", thus it cannot be used for direct potable water heating or to process heating of any kind.

## Oxygen Elimination

This boiler may only be installed in a pressurized closed-loop heating system, free of air (oxygen) and other impurities. To avoid the presence of oxygen, ensure all of the air is removed from the system during commissioning via strategically placed and adequately sized air removal devices, located throughout the heating system.

- Note**
- ☐ The Navien NCB-E boiler has a built-in air vent on top of the internal circulator to efficiently remove the air in the space heating system.
  - ☐ See the examples of system application at the end of this section detailing the installation location of the air removal device, in case an additional air removal device is required for a specific application.



### WARNING

- ☐ Immediately repair any leaks in the system plumbing to avoid the addition of make-up water; make-up water provides a source of oxygen and minerals that may lead to heat exchanger failure.
- ☐ Failure to follow these instructions will result in poor performance, unnecessary wear of system components and premature failure.

## 3.1.2 Essential Elements in a Space Heating System

### Low Water Cut Off (LWCO) Device

#### Internal LWCO

The Navien NCB-E boiler is equipped with a factory-installed, pressure-sensing type low water cutoff (LWCO) device. The minimum operation pressure for this device is 7.3 psig.

- Note**
- ☐ The boiler performs water replenishment automatically when the built-in water pressure sensor detects insufficient water level in the boiler system.
  - ☐ If the water replenishment is not completed after 5 minutes, error code E35 is displayed on the front panel requiring a manual boiler reset.

Refer to local codes to determine if a LWCO device is required for your system and ensure that the built-in device meets the requirements. Install a backflow preventer in the make-up water line to the unit if required by local codes.

#### External LWCO

Install a separate LWCO device if required by local codes. The following figure illustrates an example of typical LWCO installation.

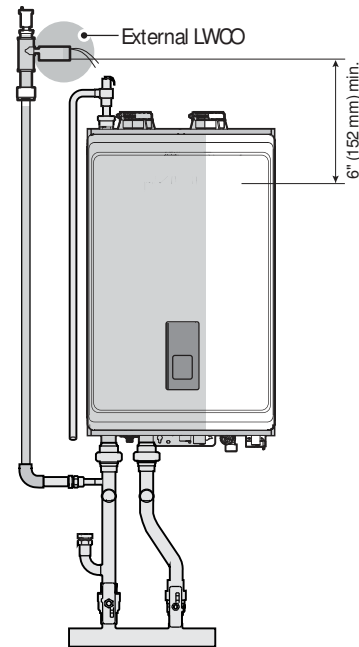

The external LWCO must be installed at least 6 in (150 mm) above the top of the heat exchanger. Refer to the following diagram for typical wiring connections of the LWCO to the boiler PCB.

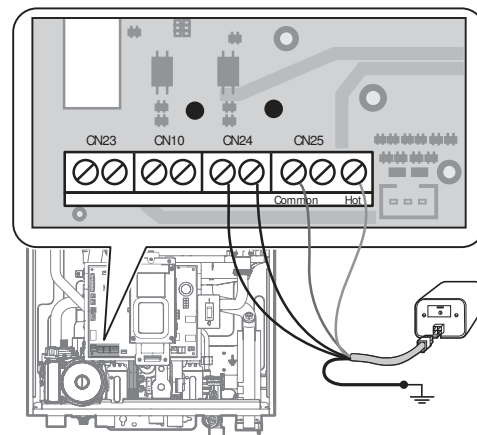

- Note**
- ☐ Remove the factory installed jumper on the LWCO terminals (CN10) prior to connecting the LWCO.
  - ☐ The boiler supplies 24VAC at the LWCO power terminals (CN15).

### Backflow Preventer

Install a backflow preventer valve in the make-up water supply to the unit as required by local codes.

### Expansion Tank

An expansion tank must be installed in the space heating piping to prevent excessive pressure from building in the system. See the examples of system application at the end of this section for the installation location. Refer to the expansion tank manufacturer's instructions for additional details.

Follow the guidelines below when installing an expansion tank.

- ☐ Connect an air separator to the expansion tank only if the air separator is located on the suction side of the system circulator.
- ☐ Navien NCB-E boiler is equipped with an auto-feeding water connection and motorized feeding valve. Therefore, installation of additional system water fill connection is not necessary in most cases.
- ☐ If an additional water fill connection is required for a specific use, install the water fill connection at the same location as the expansion tank's connection to the system.
- ☐ When replacing an expansion tank, consult the expansion tank manufacturer's literature for proper sizing.
- ☐ For diaphragm expansion tanks, always install an automatic air vent on the top side of the air separator to remove residual air from the system.

### Isolation Valves and Unions

- ☐ Full port ball valves are required for the boiler system. Failure to use full port ball valves could result in a restricted flow rate through the boiler.
- ☐ Check valves are recommended for installation. Failure to install check valves could result in a reverse flow condition during pump(s) off cycle.
- ☐ Unions are recommended for unit serviceability.

### Pressure Relief Valve

To complete the space heating system installation, you must install a  $\frac{3}{4}$ in, maximum 30 psi pressure relief valve to the pressure relief valve adapter located on the top side of the NCB-E boiler. An ASME approved HV pressure relief valve for space heating system is supplied with the boiler.

#### WARNING

- ☐ Installing the pressure relief valve improperly may result in property damage, personal injury, or death. Follow all instructions and guidelines when installing the pressure relief valve. The valve should be installed only by a licensed professional.
- ☐ The pressure relief valve must be installed vertically to the pressure relief valve adapter on the top side of the boiler, as shown in the example below, with the drain pipe outlet exiting the side of the pressure relief valve horizontally and elbowing down.

#### CAUTION

Install the pressure relief valve as close to the boiler as possible. No other valve should be installed between the pressure relief valve and boiler.

Refer to the following illustration and install a pressure relief valve to the pressure relief valve adapter located on the top corner of the NCB-E boiler. Conbraco Watts M330-ML pressure relief valve ( $\frac{3}{4}$ in, HV, Max 30 psi) is provided with the boiler.

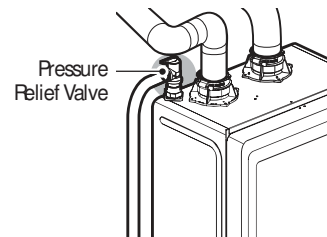

When installing the pressure relief valve, follow these guidelines:

- ☐ Ensure that the valve's discharge capacity is equal to or greater than the maximum pressure rating of the boiler's space heating system.
- ☐ Ensure that the maximum BTU/H rating on the pressure relief valve is equal to or greater than the maximum input BTU/H rating of the boiler.
- ☐ Direct the discharge piping of the pressure relief valve so that hot water does not splash on operator, or any nearby equipment.
- ☐ Attach the discharge line to the pressure relief valve and run the end of the line to within 6-1/8" (150-300 mm) of the floor.
- ☐ Ensure that the discharge line allows for free and complete drainage without restriction. Do not install a reducing coupling or other restrictions on the discharge line.

If the relief valve discharges periodically, this may be due to thermal expansion caused by expansion tank waterlogging or undersizing. Do not plug the relief valve.

### 3.1.3 Space Heating System Piping

When connecting the space heating system, follow these guidelines:

- ☐ Tighten the connection valves with care to avoid damage.
- ☐ After installing the boiler, clean the strainer for space heating return. Then, test the boiler for proper space heating flow and inspect for leaks. Instruct the boiler owner that the strainer must be cleaned periodically to maintain proper space heating water flow.

The Navien manifold system (optional) allows for easy separation of the Boiler-Primary loop from the System-Secondary loop(s). Refer to the following illustration for a typical water piping example with a Navien manifold system.

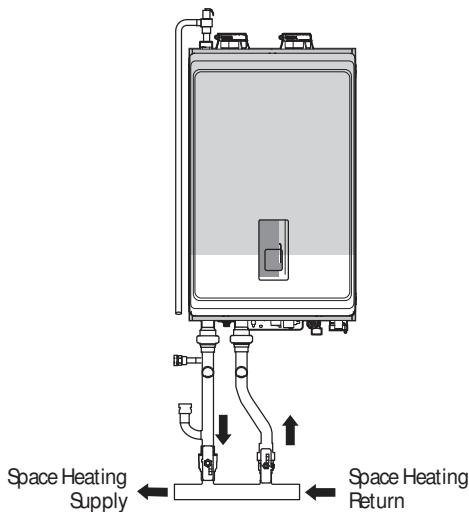

## 3.2 Installing a Domestic Hot Water (DHW) System

The Navien NCB-Eboiler provides domestic hot water continuously when flow is sensed by the flow sensor. This method is the most efficient means of heating water by allowing the boiler to operate at a lower return water temperature by minimizing standby losses, thus increasing combustion efficiency.

### 3.2.1 Guidelines for a DHW System

With its multi-purpose design, the Navien NCB-Eboiler provides hot water on demand. This means that the boiler produces DHW only when the user demands it.

The boiler recognizes a DHW demand when the flow sensor detects a DHW flow of approximately 0.5 GPM or greater. Once the flow sensor detects the flow, the boiler immediately goes into DHW mode regardless of the status of the space heating system.

Read and follow the guidelines listed below to ensure safe and proper installation of a boiler heating system.

#### Scald Hazard

Hotter water increases the risk of scald injury. There is a hot water scald potential if the DHW temperature is set too high. Be sure to follow the adjustment instructions in the boiler's operation manual.

#### About the DHW Quality

Proper maintenance of the boiler is required when water quality does not meet EPA standards. Damage caused by poor water quality is not covered under warranty. The following table shows the maximum contaminant levels allowed, based on the EPA National Secondary Drinking Water Regulations (40 CFR Part 141.3). If you suspect that your water is contaminated in any way, discontinue use of the DHW and contact an authorized technician or licensed professional.

Contaminant	Maximum Allowable Level
Total Hardness	Up to 100 mg/l (1 grains/gallon)
Aluminum	0.05 to 0.1 mg/l
Chloride	Up to 150 mg/l
Copper	Up to 1.0 mg/l
Iron	Up to 0.3 mg/l

Contaminant	Maximum Allowable Level
Manganese	Up to 0.05 mg/l
pH	6.5 to 8.5
Sulfate	Up to 105 mg/l
Total Dissolved Solids (TDS)	Up to 500 mg/l
Zinc	Up to 5 mg/l

Navien is not responsible for plugging of the domestic system by scaling or accumulation of dirt; suitable steps shall be taken by the installer and user to avoid water quality related issues.

### Freeze Protection

Navien recommends heat tracing and insulating the DHW water pipes. Pipe enclosures may be packed with insulation for added freeze protection. Freeze damage is not covered by the warranty.

## 3.2.2 Essential Elements in a DHW System

### DHW Heat Exchanger

The DHW heat exchanger installed inside the Navien NCB-Eboiler has been tested and certified in accordance with IAPMO standard PS9 .

### Drain and Isolation Valves

Install drain and isolation valves on the inlet and outlet of the DHW heat exchanger, so it can be flushed free of possible build-up caused by dirt or hard water.

### DHW Filter

The Navien NCB-Eboiler has built-in DHW filter at the entrance of the cold water inlet. Clean the filter periodically to ensure that the filter is not obstructed creating disturbance in the flow. Failure to protect the flow sensor from dirt and debris will cause the boiler to malfunction.

### Flow Restrictor (pressure regulator)

A flow restrictor is used to avoid excessive flow at the faucets. The Navien NCB-Eboiler has a built-in flow restrictor at the cold water inlet adapter to limit the overall flow of domestic hot water. Follow the instructions below when installing a flow restrictor:

#### CAUTION

Do not operate the boiler without the flow restrictor installed. Refer to the flow restrictor specifications and install an appropriate valve for proper operation.

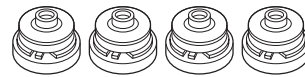

All Navien NCB-Eboilers are shipped from the factory with three flow restrictors included for different flow rates. Each flow restrictor allows for a specified amount of water to flow through the unit. A flow restrictor valve is pre-installed at the cold water inlet adapter (at the tip of the cold water inlet filter).

The flow restrictors are color coded for easier identification. Refer to the table below for detailed specification. Factory-installed flow restrictors and specifications are as follows:

Valve color	Applied Model	Specification*
Orange	NCB-100E, pre-installed	5.6 GPM
Yellow	NCB-100E, pre-installed	5.0 GPM
Blue	NCB-180E, pre-installed	4.0 GPM
Pink	NCB-150E, pre-installed	2.6 GPM

\* Flow rate in GPM, as factory tested with 56 psi water pressure.

The following graph describes the water flow rate (in GPM) and water pressure (in psi) specifications for each flow restrictor.

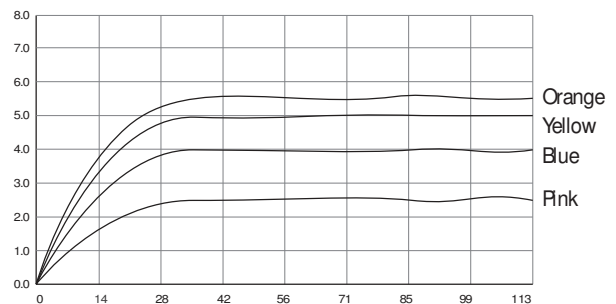

If necessary, replace the factory-installed flow restrictor with one that satisfies your flow requirements. Follow these instructions to replace the flow restrictor.

1. Locate the cold water inlet adapter on the bottom of the unit.

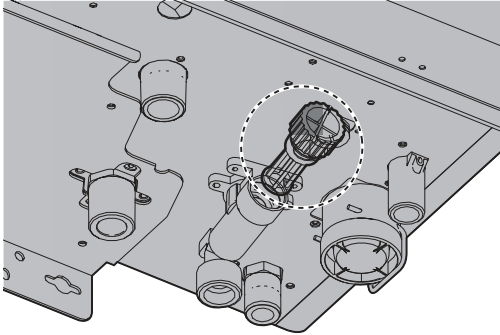

2. Turn the knob counterclockwise to remove the water inlet filter. The flow restrictor is attached at the tip of the filter assembly.

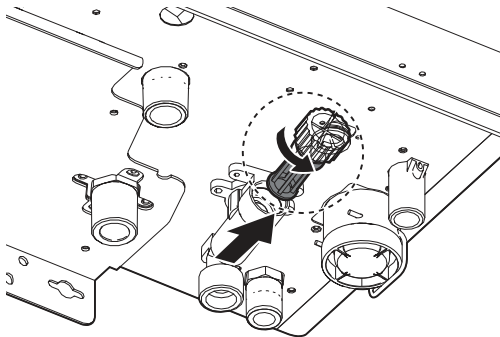

3. Remove the current flow restrictor and replace it with one that provides an appropriate flow rate.



### Pressure Relief Valve for DHW

To complete the installation of the DHW system, you must install an approved  $\frac{3}{4}$  in, maximum 50 psi pressure relief valve on the hot water outlet. The Navien NCB-Eboiler has a built-in high temperature shut off switch, so install a “pressure only” relief valve.

#### WARNING

- Installing the pressure relief valve improperly may result in property damage, personal injury, or death. Follow all instructions and guidelines when installing the pressure relief valve. The valve should be installed only by a licensed professional.
- The pressure relief valve must be installed at the boiler outlet and in the vertical position, as shown in the example below, with the drain pipe outlet exiting the side of the pressure relief valve horizontally and elbowing down.

The DHW pressure relief valve is not supplied, but is required. The following examples are pressure relief valves approved for use with the boiler:

- Wilkins P-1000A (Zurn Industries)
- Conbraco 17-10-00
- Watts Industries 3L (M7)
- Cash Acme FWL-1/2 in

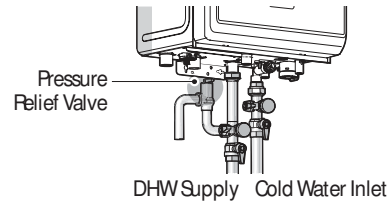

#### CAUTION

Install the pressure relief valve as close to the boiler as possible. No other valve should be installed between the pressure relief valve and boiler.

When installing pressure relief valve, follow these guidelines:

- ❑ Ensure that the valve's discharge capacity is equal to or greater than the maximum pressure rating of the boiler's DHW system.
- ❑ Ensure that the maximum BTU/H rating on the pressure relief valve is equal to or greater than the maximum input BTU/H rating of the boiler.
- ❑ Direct the discharge piping of the pressure relief valve so that hot water does not splash on operator, or any nearby equipment.
- ❑ Attach the discharge line to the pressure relief valve and run the end of the line to within 6-1/8" (150-300 mm) of the floor.
- ❑ Ensure that the discharge line allows for free and complete drainage without restriction. Do not install a reducing coupling or other restrictions on the discharge line.
- ❑ If the relief valve discharges periodically, this may be due to thermal expansion in a closed water supply system. Contact the water supplier or local plumbing inspector on how to correct the situation. Do not plug the relief valve.

### 3.2.3 DHW System Piping

#### ! CAUTION

To comply with ASME or CPN requirements, an additional high temperature limitation device may be needed. Consult your local code requirements to determine if this device is required.

Refer to the following illustration for a typical DHW piping example for the boiler.

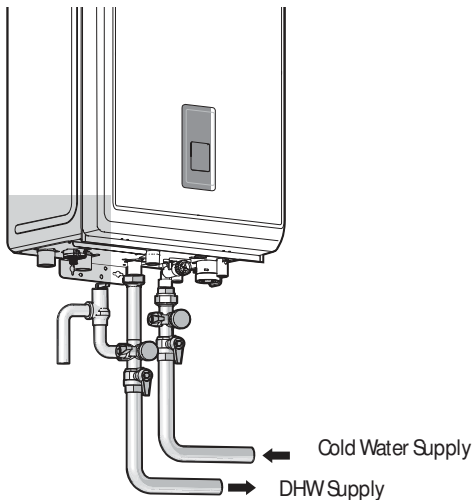

When installing the DHW system, follow these guidelines:

- ❑ Use only pipes, fittings, valves, and other components (such as solder), that are approved for use in potable water systems.
- ❑ Tighten the connection valves with care to avoid damage.
- ❑ Navien recommends using unions and manual shut-off valves on the cold water inlet and DHW outlet.
- ❑ Keep the hot water piping system as short as possible, to deliver hot water to the fixtures more quickly.
- ❑ To conserve water and energy, insulate the DHW supply and DHW recirculation lines (if applicable). Do not cover the drains or pressure relief valves.
- ❑ After installing the boiler, clean the cold water inlet filter. Then, test the boiler for proper DHW supply and inspect for leaks. Instruct the boiler owner that the filter must be cleaned periodically to maintain proper DHW flow.

### 3.3 Connecting the Condensate Drain

The Navien NCB-E boiler creates condensation when it operates. This condensation has an acidic pH of 3-5. Follow all local codes and regulations when disposing of condensate from the boiler. We recommend draining the condensate into a laundry tub, as the alkali in laundry detergent will neutralize the acid in the condensate. However, other suitable waste drain locations may be used according to the local codes.

#### ! CAUTION

- ❑ Do not cap or plug the integrated condensate line. If prevented from draining, condensate can damage the boiler.
- ❑ The condensate line must have a negative slope to drain properly.

Before connecting the condensate drain, choose one of the following disposal options:

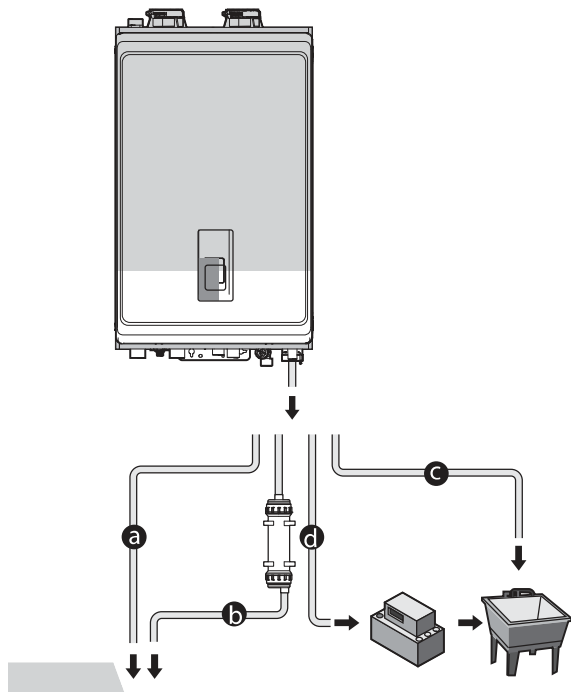

- a. From the boiler directly into an external drain
- b. From the boiler, through a neutralizing agent, and then into an external drain

**Note** If you choose this option, the neutralizing agent must be replaced periodically. Depletion of the neutralizing agent will vary, based on the usage rate of the boiler. During the first year of operation, the neutralizer should be checked every few months for depletion and replaced as needed.

- c. From the boiler into a laundry tub.

**Note** The bottom of the boiler must be higher than the top of the laundry tub to use this option. The condensate line must have a negative slope to drain properly.

- d. From the boiler into a condensate pump, and then into a laundry tub.

**Note** A pump can be used when there is a long distance between the boiler and the laundry tub or when the bottom of the boiler is lower than the top of the laundry tub.

To connect the condensate drain:

- 1. Connect a drain line to the  $\frac{1}{2}$ in fitting at the bottom of the boiler. Use only corrosion-resistant material for the drain line, such as PVC or CPVC. Do not reduce the size of this fitting or the drain line to less than  $\frac{1}{2}$ in.

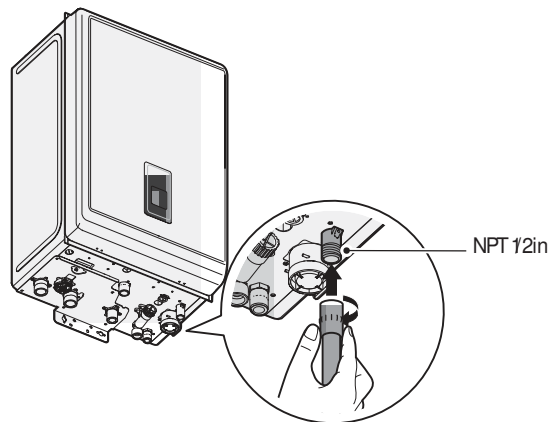

- 2. Place the free end of the drain line into an appropriate drain.
3. If you are using a condensate pump, ensure that the pump allows for up to  $\frac{1}{2}$  GPH of drainage for each boiler in the system.
- 4. If you are not using a condensate pump, ensure that the drain line is pitched downward at a minimum slope of  $\frac{1}{4}$ in per foot.



### 3.3.1 Condensate Neutralizer Kit

#### WARNING

- ❑ To avoid damaging the appliance, the neutralizer inlet and discharge must be lower than the condensate drain.
- ❑ Do NOT allow exhaust flue gases to vent through the neutralizer. Leakage can cause injury or death from carbon monoxide.
- ❑ The connection between the appliance and the neutralizer must be installed to prevent the backflow of condensate into the appliance.
- ❑ Do not connect more than one appliance to the neutralizer.

If option 'b' is selected for condensate disposal, the Navien condensate neutralizer kit is recommended. The condensate from the appliance flows through the neutralizing media and increases the pH of the condensate. An increased pH prevents corrosion of the installation's drainage system and the public sewer system.

#### Installation guidelines

- ❑ The inlet has a center connection port and the outlet has an offset connection.
- ❑ Install the neutralizer on the wall or the floor and secure it using the brackets supplied with the kit.
- ❑ If the neutralizer is installed horizontally, rotate the neutralizer to position the outlet at the highest point (Figure 15).
- ❑ If the neutralizer is mounted vertically, ensure that the outlet is higher than the inlet (Figure 16).
- ❑ Ensure that the condensate runs freely to the drain.
- ❑ Ensure all connections are made to prevent the backflow of condensate. Use corrosion resistant piping and secure all piping to prevent movement.

**Note** Do not install condensate piping in areas where the temperature drops below freezing point. Protect piping in high pedestrian areas from damage and vibration.

- ❑ For increased safety when the condensate drain blocks, install a Y-fitting. Connect the Y-fitting as shown in the installation diagram and ensure that the condensate runs freely to the drain.
- ❑ Ensure that the discharge connection is accessible. Access to the discharge connection is required for maintenance and pH testing.
- ❑ If there is insufficient gradient for drainage, install a drainage pump designed for boiler and water heater condensate removal.

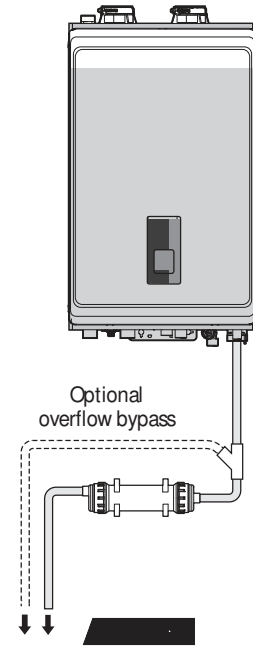

Figure 15 Horizontal installation

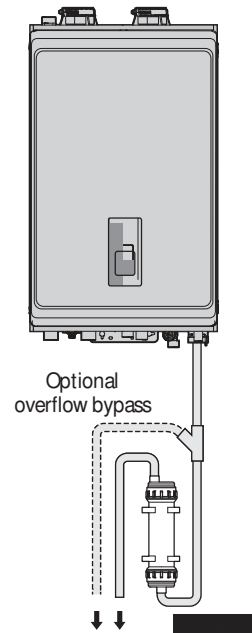

Figure 16 Vertical installation

## Maintenance

Periodically monitor the level of media in the neutralizer and test the pH level at the outlet. We recommend an annual pH test using recognized test strips or an electronic pH meter to obtain precise measurements. Replace the neutralizing media when the pH drops below the minimum level required by the local water authority. If the pH level is not specified, replace the neutralizing media when the pH is below 6.0. For replacement media, contact your local Navien distributor.

## 3.4 System Fill Connection

Before filling the boiler, open the pressure relief valve by lifting the lever on top, and open the air vent cap to allow the system to fill properly. Close the pressure relief valve when the system is full.

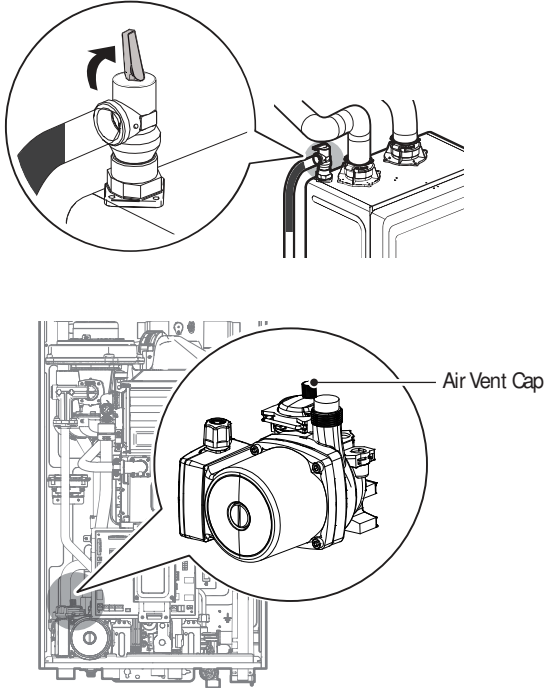

### ⚠ CAUTION

Ensure that the pressure relief valve is closed before testing or operating the system.

### 3.4.1 Built-in Water Fill Connection

Navien NCB-Eboiler is equipped with an auto-feeding water connection and motorized feeding valve. Therefore, installation of additional system water fill connection is not necessary in most cases. See the following figure for an example of a water fill installation using the built-in connection.

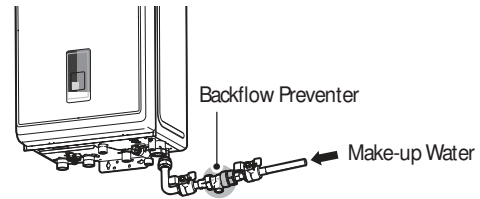

### 3.4.2 External Water Fill Connection

External water fill connection may be installed on the system piping if it is required for specific applications. See the following figure for an example of external water fill installation on the system piping.

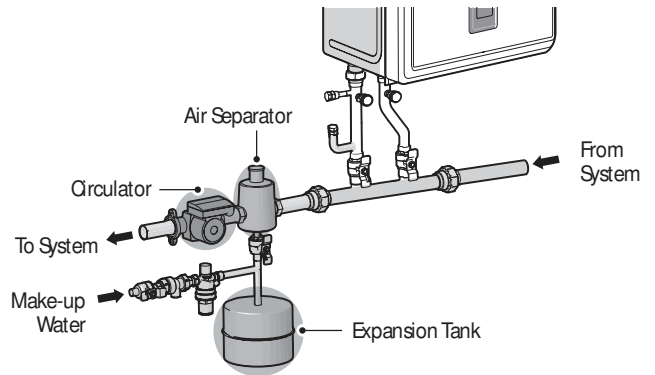





## 3.5 Testing the Water System



### WARNING

Ensure that the boiler is full of water before firing the burner. Operating the unit without filling it will damage the boiler. Such damage is not covered by the warranty, and may result in property damage, severe personal injury, or death.

Perform a fill test after installing the boiler's water system to make sure that the system has been installed properly. Follow the instructions below to perform a fill test on the water system.

-  Fill the system only after ensuring that the water chemistry meets the requirements listed in this manual.
-  Close the manual and automatic air vents and the boiler drain valve.
- 3. Fill the boiler to the correct system pressure. The correct pressure will vary with each application. The typical cold water fill pressure for a residential system is  psi. The pressure will rise when the boiler is turned on and the system water temperature increases. The operating pressure must never exceed the relief valve pressure setting.
-  At initial fill and during boiler start-up and testing, check the system thoroughly for leaks. Repair any leaks before proceeding further.



### WARNING

Eliminate all system leaks. The continual introduction of fresh makeup water will reduce boiler life. Minerals can build up in the heat exchanger, reducing heat transfer, overheating the heat exchanger and causing heat exchanger failure.

The system may have residual substances that could affect water chemistry. After the system has been filled and leak tested, verify that water pH and chlorine concentrations are within the acceptable range by performing sample testing.



### CAUTION









Before operating the boiler for the first time, ensure that the boiler system is filled with water. Purge the air inside the system to avoid damage to the boiler.

## 3.6 Examples of System Applications

Refer to the following examples to properly implement a system for space heating, DHW supply, or both. These examples are provided to suggest basic guidelines when you install the boiler system. However, the actual installation may vary depending on the circumstances, local building codes, or state regulations. Check the local building codes and state regulations thoroughly before installation, and comply with them fully.

### 3.6.1 Considerations for System Applications

Read and follow the guidelines listed below when installing system piping for the Navien NCB-Eboiler:

-  System application drawings are intended to explain the system piping concept only.
-  When installing a mixing valve on the DHW piping, ensure that the cold water pressure does not exceed the hot water pressure.
-  For the upstream side of all circulators, use straight pipes with a minimum diameter of  (12.7 mm).
-  Keep the auto feeder connection cap closed unless the auto feeder is in use and piping has been connected to the auto feeder valve.
-  Provide a system expansion tank following the guidelines on page .
-  Installations must comply with all local codes. In Massachusetts, a vacuum relief valve must be installed in the cold water line per .

#### Air Removal

The boiler and system plumbing layout must be configured to promote the removal of air from the water. Air vents and bleeders must be strategically placed throughout the system to aid in purging the air from the system during commissioning of the boiler. The system must also employ the use of a strategically located air removal device, such as an air scoop or micro-bubbler, designed to remove the air from the water as it flows through the system.

Follow the installation instructions included with the air removal device when placing it in the system; air removal devices generally work better when placed higher in the system. Always locate air removal devices in areas of the system that have a guaranteed positive pressure, e.g., in close proximity to the water fill and expansion tank.

**Note** The Navien NCB-E boilers have a built-in air vent on top of the internal circulator to purge air from the boiler system.

### Expansion Tank

The expansion tank must be sized in accordance with the water volume of the system as well as the firing rate of the appliance. It is important to locate the expansion tank, and make-up water fill, on the inlet side of any circulator in the system, as doing so will guarantee the lowest pressure in the system will be at least equal to the tank and make-up water pressure.

Ensure the expansion tank cannot become isolated from the boiler anytime the system is operating. Failure to follow these instructions may lead to discharge from the pressure relief valve, which may result in property damage or injury.

**Note** The installation of flow checks, motorized valves or other shutoff devices (other than for the purpose of servicing) are not permitted between the location of the "Closely Spaced Tees" and the expansion tank.

### Air Handler Interface

The Navien NCB-E boiler can control the operation of an air handler when a thermostat is used in combination with the air handling unit. The Air Handler Interface is designed to stop air handler operation when the boiler's space heating function is not operating due to DHW supply demands, boiler errors, or low water conditions.

The air handler contacts (A/H) turn off when the following conditions arise:

- ☐ The PCB DIP SW #7 is set to ON.
- ☐ Thermostat is turned off.
- ☐ The boiler is supplying DHW, or it is in stand-by mode for DHW demand.
- ☐ Level Errors, or higher level errors occur.
- ☐ The boiler is turned off.
- ☐ Make-up water auto-feeding is in progress.

### Thermostat Configuration for the Air Handler Interface

Set the PCB DIP SW #7 to down position (OFF) to use a thermostat with the Air Handler.

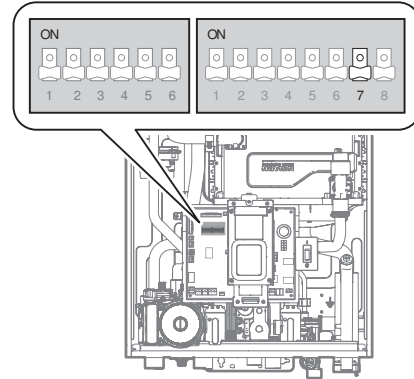

Refer to the following diagram for wiring connections.

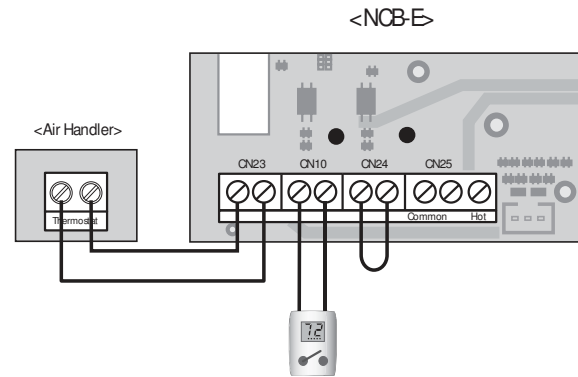

### WARNING

- ☐ The boiler, when used in conjunction with a refrigeration system, must be installed so that the chilled medium is piped in parallel with the heating boiler. Appropriate valves must be used to prevent the chilled medium from entering the boiler.
- ☐ If the boiler is connected to heating coils located in air handling units where they can be exposed to refrigerated air, use flow control valves or other automatic means to prevent gravity circulation of the boiler water during the cooling cycle.

### 3.6.2 System Application - Zone System with Zone Valves

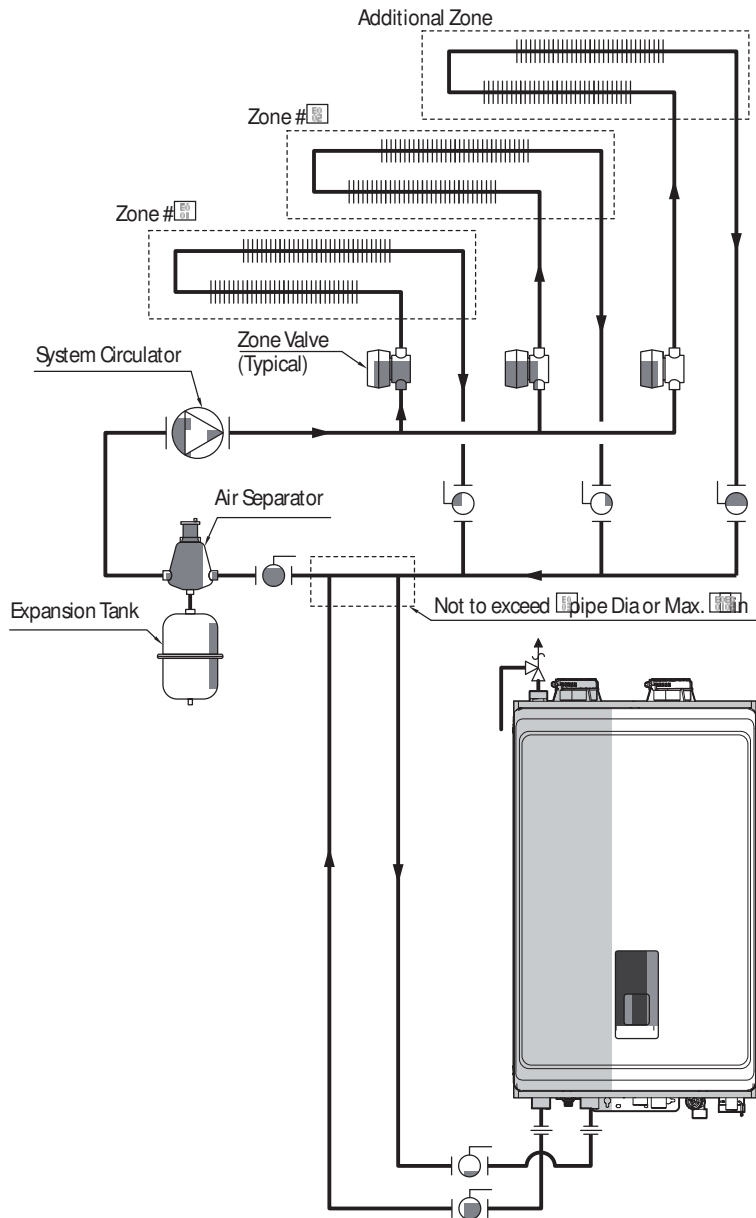

- Note**
- System application drawings are intended to explain the system piping concept only.
  - Refer to 3.1. [ ] System Fill Connection on page [ ] for make-up fill connections and refer to the requirements of your local codes to ensure compliance.

#### Wiring Diagram

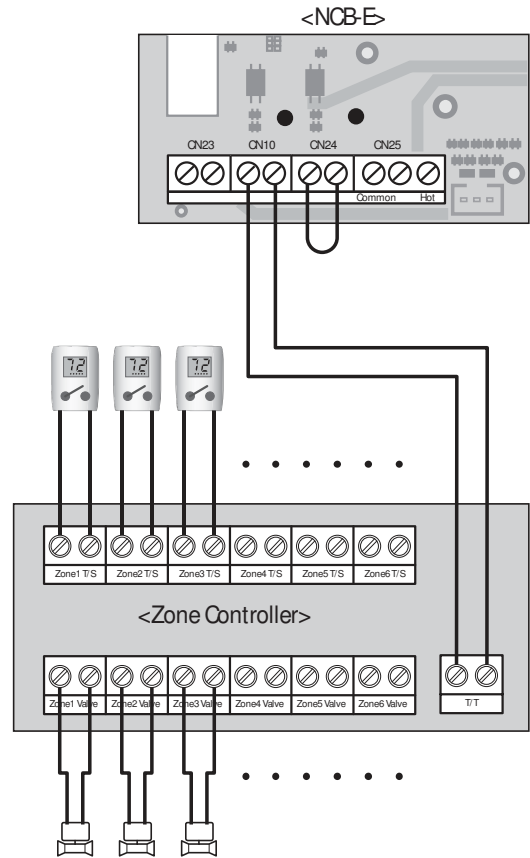

### 3.6.3 System Application - Zone System with Circulators

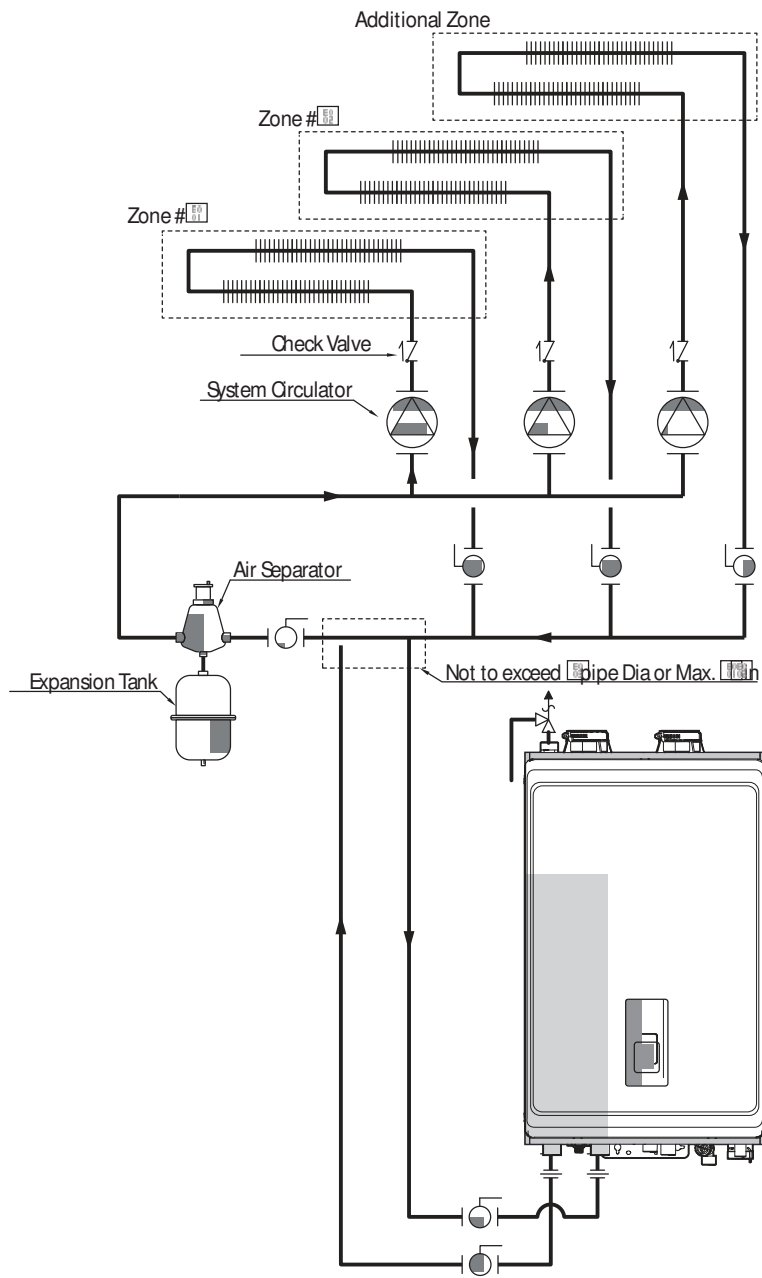

- Note**
- 1. System application drawings are intended to explain the system piping concept only.
  - 2. Refer to 3. [ ] System Fill Connection on page [ ] for make-up fill connections and refer to the requirements of your local codes to ensure compliance.

Wiring Diagram

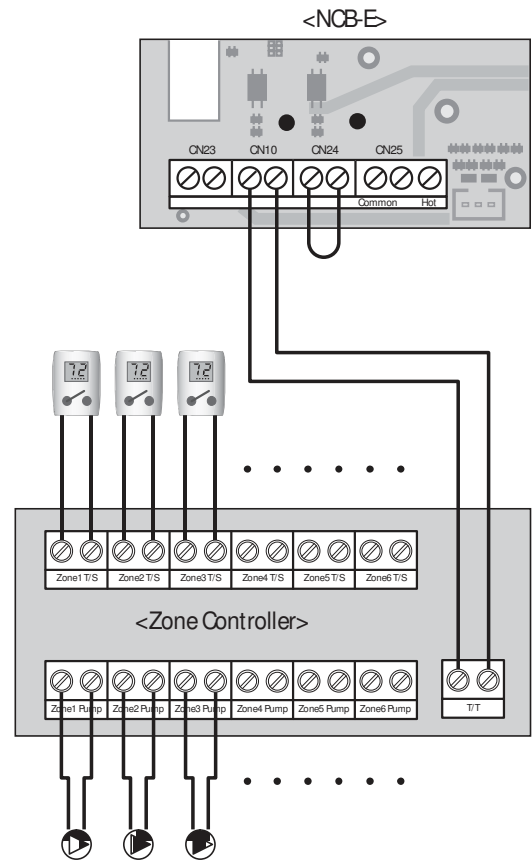

### 3.6.4 System Application - Air Handler System

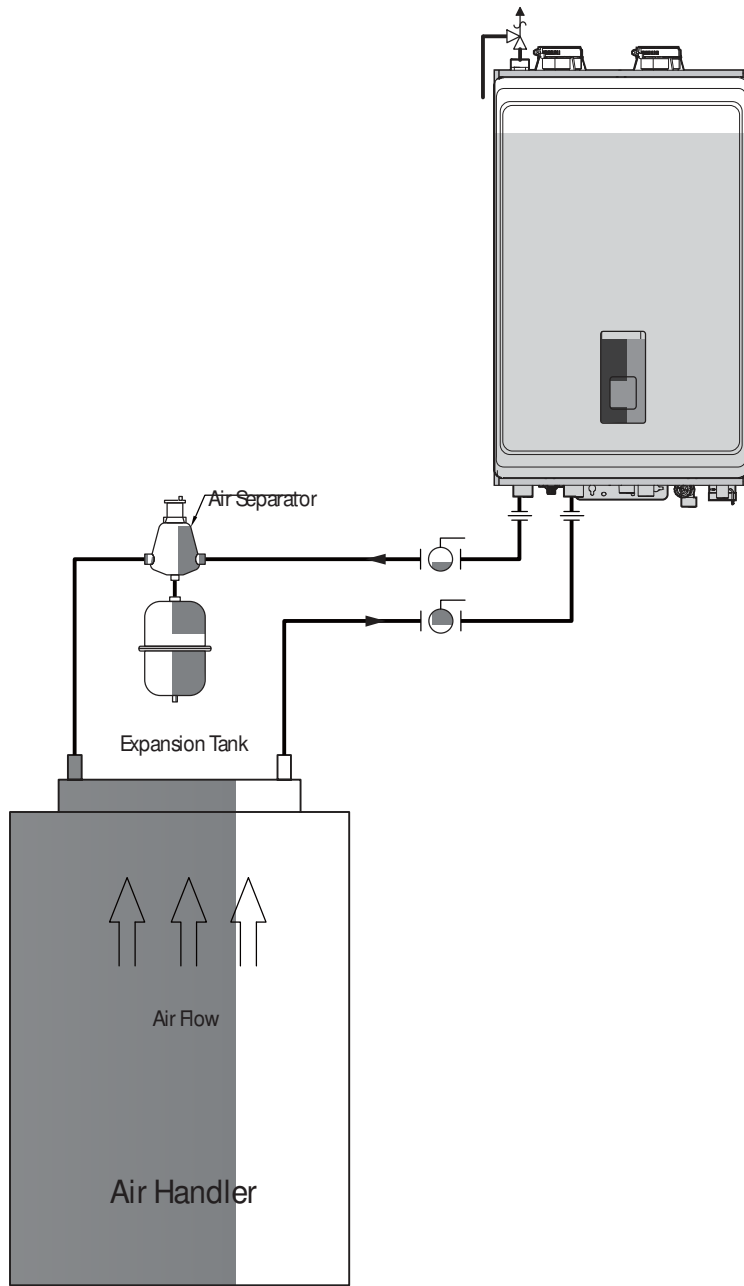

- Note**
- ▣ System application drawings are intended to explain the system piping concept only.
  - ▣ Refer to 3.1.1 System Fill Connection on page 16 for make-up fill connections and refer to the requirements of your local codes to ensure compliance.
  - ▣ Boiler side piping to the air handler which exceeds the capabilities of the internal boiler circulator requires primary/secondary piping configuration with a separate system circulator.
  - ▣ Air handlers with an internal circulator shall be piped either with a crossover pipe at the AHU or in a primary/secondary configuration with the boiler.

Wiring Diagram

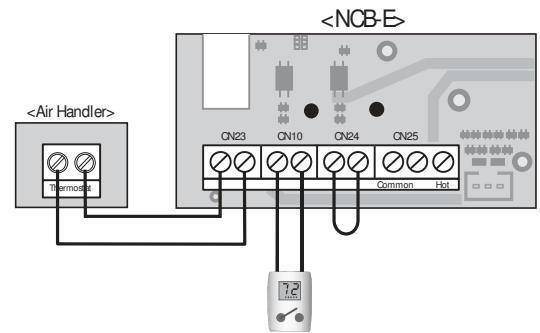

## 4. Installing a Cascading System

When installing a cascading system, carefully consider the design of the system and the features of the installation location. Follow all local codes and regulations, as well as all guidelines for installing the combination boiler and water heaters. The following sections describe additional considerations that are specific to installing cascading systems. Read them carefully before designing or installing the system.

### 4.1 Connecting Water Supplies

Several options are available for plumbing a cascading system. The setup you choose will vary based on the installation location, local building codes, and other factors. Follow all applicable regulations when installing a cascading system.

You can install one NCB-E boiler with multiple NPE/ NR/ NP series water heaters to configure a cascade system. In the system, the boiler must be configured as the master unit. You can connect up to 15 water heaters to one NCB-E boiler to meet high-volume hot water demands by using Navien Ready-Link communication cables and following the set-up procedures in this section; additional controllers are not necessary. The following is one of the possible connection options:

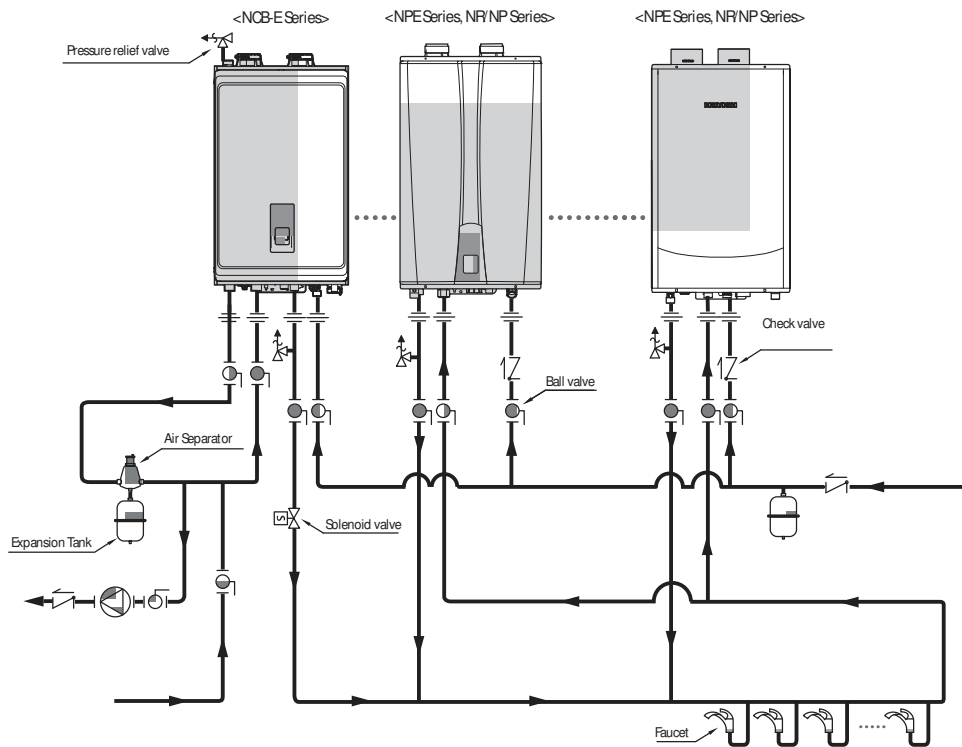

- ❑ Install a 120V AC (max 15A) normally closed solenoid valve on the NCB-E boiler's hot water supply, and then connect the valve wires to the external power port (Extern. Power) on the main PCB (refer to the wiring diagram). A slow-closing solenoid is recommended to prevent water hammer from occurring.
- ❑ When linking multiple water heaters to NCB-E series boiler, only the master unit can provide space heating and slave units must be configured for DHW only (You can set only the NCB-E boiler as the master unit in the cascade system, and the master unit controls the power on/off status of all the slave units in the system).
- ❑ Once turned on by the master unit, the water heaters will operate in stages to satisfy the DHW demands.
- ❑ After completing the cascade settings and saving the changes, the boiler and water heater units must be turned off then turned back on for the changes to take effect.
- ❑ If errors occur while operating a cascade system, the relevant errors are displayed in the display of the failing unit (with the exception of NR/ NP units).
- ❑ Power supply to the units must be OFF during the system piping.

**Note**

The recommended recirculation flow rate for each water heater is 4 GPM. Depending on the number of water heaters and the diameter of the recirculation line, it may not be necessary to connect all the NPE/ NR/ NP "A" series water heaters to the recirculation line. If this is the case, set any unconnected "A" model water heaters to internal recirculation mode.



### 4.1.1 Piping Sizes and Considerations

When plumbing a cascading system, consider the following pipe diameters and flow rates. Note that flow rates above 6.6 ft/s may cause pipe erosion. These specifications may vary depending on installation conditions.

Qty	ΔT=54°F Flow rate (GPM)	Water Velocity (ft/s)	Pipe Diameter (mm/in)	
1	7.19	4.78	10A	3/4 in.
2	14.38	5.60	15A	1 in.
3	21.57	5.50	30A	1 1/4 in.
4	28.77	5.40	40A	1 1/2 in.
5	35.96	6.53	50A	1 3/4 in.
6	43.15	6.19	50A	1 3/4 in.
7	50.34	5.84	50A	1 3/4 in.
8	57.5	6.00	50A	1 3/4 in.
9	64.71	6.39	65A	1 3/4 in.
10	71.91	6.75	65A	1 3/4 in.
11	79.11	5.30	65A	1 3/4 in.
12	86.30	5.80	65A	1 3/4 in.
13	93.49	6.33	65A	1 3/4 in.
14	100.68	6.79	65A	1 3/4 in.
15	107.87	5.40	80A	3 in.
16	115.07	5.40	80A	3 in.
17	122.26	5.80	80A	3 in.
18	129.45	6.40	80A	3 in.
19	136.64	6.15	80A	3 in.
20	143.83	6.83	80A	3 in.
21	151.03	6.06	100A	1 in.
22	158.22	6.15	100A	1 in.
23	165.41	6.15	100A	1 in.
24	172.60	6.65	100A	1 in.
25	179.79	6.85	100A	1 in.
26	186.98	5.05	100A	1 in.
27	194.17	5.40	100A	1 in.
28	201.36	5.40	100A	1 in.
29	208.56	5.60	100A	1 in.
30	215.75	5.80	100A	1 in.

**Note** The table above is based on model NCB-100E.

### 4.2 Connecting the Communication Cables

You can connect one NCB-E boiler with up to 15 Navien water heaters, using the Ready-Link communication cables. Select the NCB-E series combination boiler in the cascading system as the master unit, and then connect the water heaters to it as slaves. Before making any connections, ensure that the power is turned off to all the units.

Connect the Ready-Link cables to the J6 port of the master unit and to the J6 port of the slave water heaters (on the right side of the front panel):

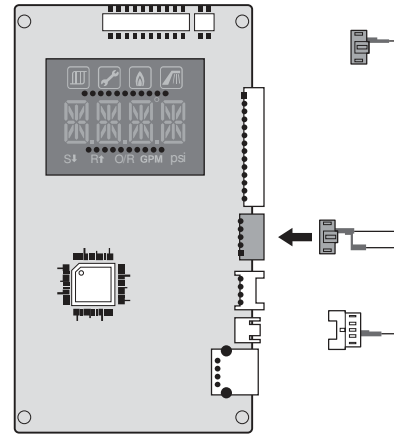

**Note** For NR/NP units, connect the Ready-Link cable to the CN9 port on the main PCB.

### 4.3 Configuring the Communication Settings

After connecting the Ready-Link communication cables, restore power to the combination boiler and turn on all water heaters using the Power button.

#### 4.3.1 Cascade Protocol Settings

Cascade protocol may be set for different communication speeds according to the type of water heater units installed in the system. Refer to "Setting the Cascade Protocol" on page 6 and match the communication settings accordingly.

Item	Description
NPE	Use this setting when all the slave units are NPE water heaters.
NR/NP	Use this setting when the slave units consist of NR/NP water heaters, or a combination of NPE and NR/NP water heaters.

### 4.3.2 Cascade System Settings

To configure the cascade communication settings:

- On the master NCB-Eboiler, press and hold the Diagnostic and Up(+) buttons for more than 5 seconds. "MA.00" will appear on the display to confirm that this combination boiler is set as the master.

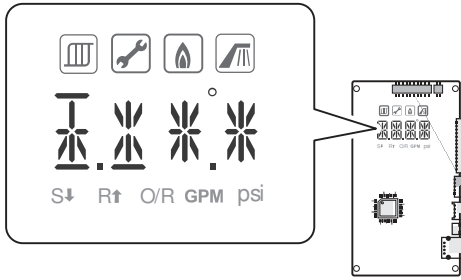

- On the slave water heaters, press and hold the Diagnostic and Down(-) buttons for more than 5 seconds. "SL.00" will appear on the display to confirm that this water heater is set as a slave.

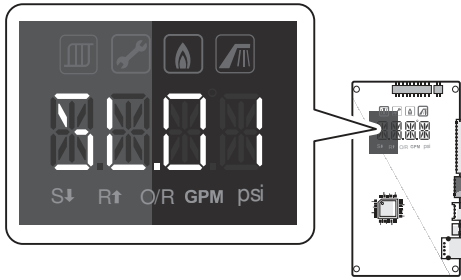

- Repeat step 2 to configure the rest of the slave units in the system.
- On the master NCB-Eboiler, press and hold the Diagnostic and Up(+) buttons for more than 5 seconds. All the display screens on the configured units will return to the temperature display.

### Note

- To add additional slaves at a later time, repeat step 2.
- Cascade communication setup must be completed within 1 hour. Otherwise, all units will return to the normal operation mode and the cascade mode will be turned off.
- To cancel the cascading communication setup, on the master combination boiler, press and hold the Diagnostic and Reset buttons for more than 5 seconds. The water heaters will revert to independent operation. Repeat steps 1 and 2 to reassign the master combination boiler.
- To replace the master unit, cancel the current cascade mode configuration and repeat the steps 1 and 2 on the new master unit.

### 4.3.3 Cascade Set-up Procedure for NP/NR Series Models

To configure the NR/NP series water heaters for a cascade system, follow the instructions below:

- Press the SW3 and SW4 (service switches on the main PCB) simultaneously for more than 3 seconds on the NP/NR series water heater. FND 1 on the main PCB will display "S00.0" to confirm that this water heater is set as the slave unit #1.

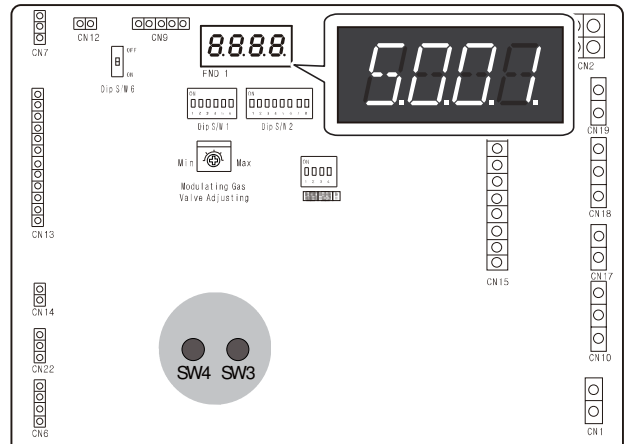

- Repeat step 1 on the other NR/NP series water heaters to add more NR/NP slave units.

## 5. Connecting the Gas Supply

### WARNING

- ❑ Before connecting the gas supply, determine the gas type and pressure for the boiler by referring to the rating plate. Use only the same gas type indicated on the rating plate. Using a different gas type will result in abnormal combustion and malfunction of the boiler. Gas supplies should be connected by a licensed professional only.
- ❑ The appliance and its gas connection must be leak tested before placing the appliance in operation.
- ❑ This boiler cannot be converted from natural gas to propane or vice versa without a Navien gas conversion kit. Do not attempt a field conversion of this boiler without a Navien gas conversion kit. Doing so will result in dangerous operating conditions and will void the warranty.

Navien recommends connecting the boiler as the first device downstream of the gas meter, to ensure a sufficient gas supply.

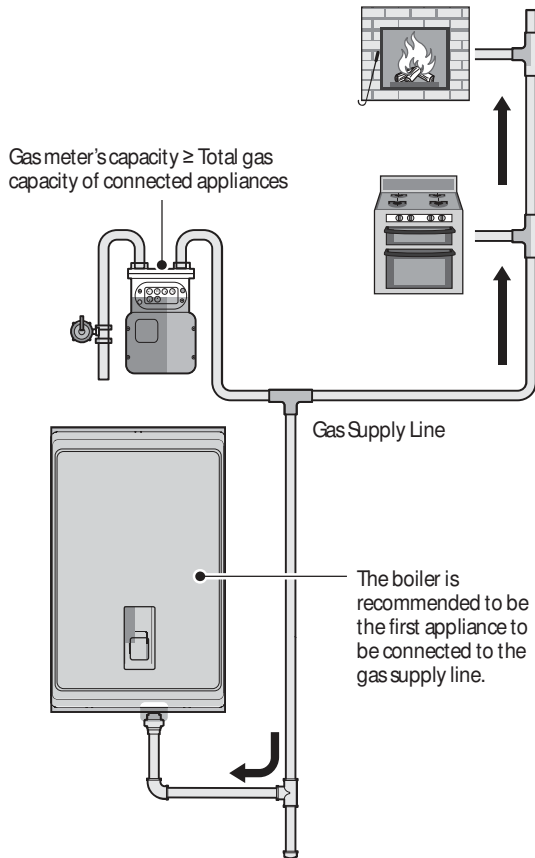

To connect the gas supply:

- ❑ Determine the gas type and pressure for the boiler by referring to the rating plate.
- ❑ Perform a pressure test on the main gas supply line.
3. Purge the gas line of any debris.
- ❑ Determine the proper size and type for the gas line. Refer to the tables that follow.
5. Install full port valves on the gas supply line and boiler.
6. Connect the gas supply line.
7. Test the supply line, all connection points, and the boiler for gas leaks.

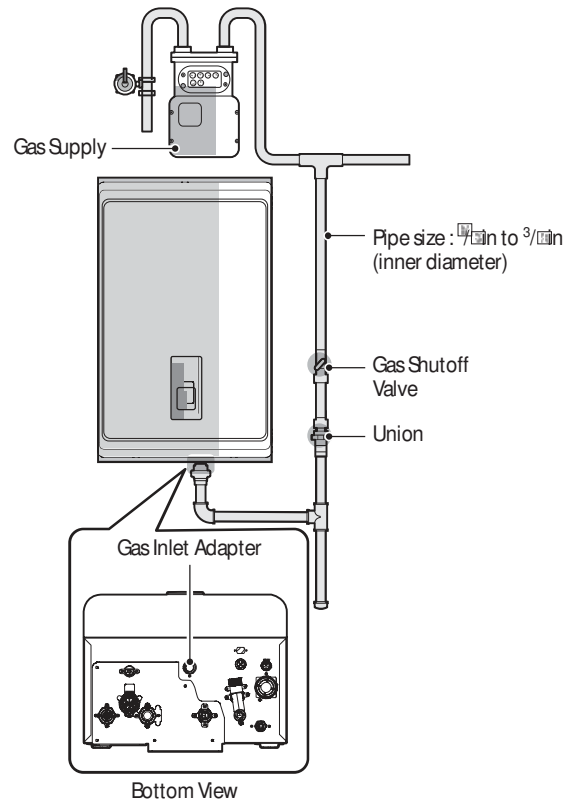

### CAUTION

- ❑ Install a manual gas shut-off valve between the gas supply line and the boiler.
- ❑ A sediment trap must be provided upstream of the gas controls.

**Note**

- ⊠ Tighten the boiler connection valves with care to avoid damage.
- ⊠ The gas connection fitting on all boilers is  $3/8$ " in
- ⊠  $1/2$ " in rigid pipe can be used; refer to the sizing tables on the preceding pages for limitations. Avoid using  $1/2$ " in corrugated connectors or tubing as noise may occur.



Corrugated Connector

- ⊠ When using flexible gas lines, ensure that the pipe's inner diameter and connector is sufficient to supply the required BTUs. Also, ensure that the flexible line has no crimps or tight bends in it, as this will restrict gas flow.
- ⊠ When using rigid pipe, Navien recommends the installation of a union on the gas supply line close to the boiler, to facilitate any future maintenance or service.



**CAUTION**

Prior to using an excess flow valve (EFV) in the gas line, check the manufacturer's minimum and maximum flow capacity rating. An improperly sized EFV will not allow for a full flow of gas to the boiler and may cause improper operation.

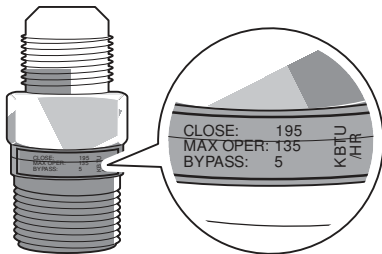

Excess Flow Valve

Typical LP Gas piping examples:

2 Stage System with Multiple Regulators (Recommended)

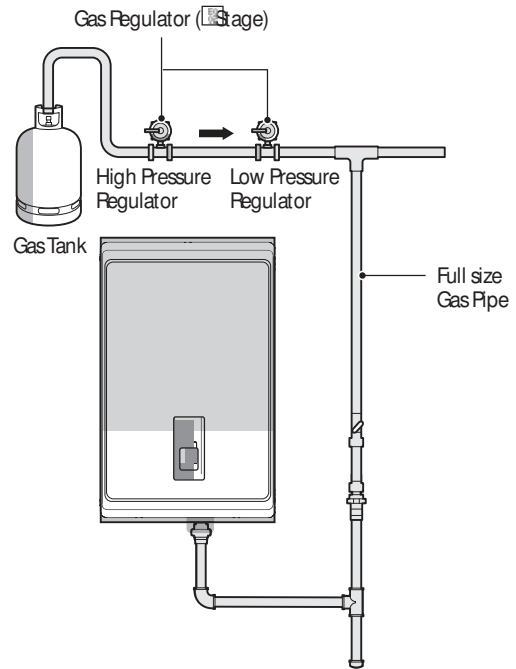

Single Regulator System

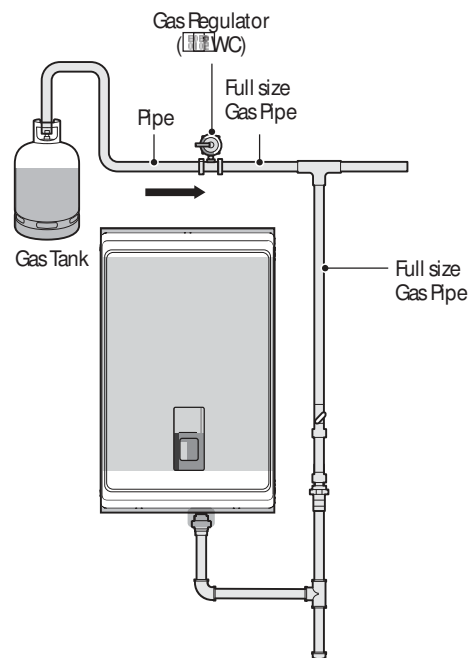

## 5.1 Gas Pipe Sizing Tables

The following tables are referenced from [2018 National Fuel Gas Code](#) for reference only. Please consult the gas pipe manufacturer for actual pipe capacities.

### Maximum Natural Gas Delivery Capacity

in Cubic Feet (ft<sup>3</sup>) per Hour (0.60 Specific Gravity; 0.5 in WC Pressure Drop). Contact your gas supplier for BTU/ft<sup>3</sup> ratings. Use 1,000 BTU/ft<sup>3</sup> for simplified calculations. This table is recommended for supply pressures less than 6 in WC.

Pipe Size	Length (including fittings)										
	10 ft (3 m)	20 ft (6 m)	30 ft (9 m)	40 ft (12 m)	50 ft (15 m)	60 ft (18 m)	70 ft (21 m)	80 ft (24 m)	90 ft (27 m)	100 ft (30 m)	125 ft (38 m)
3/4 in	360	427	499	570	651	737	826	917	1010	1105	910
1 in	678	666	3769	310	382	457	537	620	707	795	873
1 1/4 in	1390	957	768	657	583	518	466	419	379	340	355
1 1/2 in	1090	1130	1150	985	873	791	718	677	635	600	531
2 in	1010	1760	1150	1900	1680	1510	1400	1300	1210	1160	1010
2 1/2 in	6100	4100	3,530	3,010	2,680	2,430	2,230	2,080	1,950	1,810	1,630
3 in	11300	7,780	6,150	5,350	4,710	4,190	3,950	3,670	3,450	3,260	2,890
4 in	13100	5,900	4,700	4,090	3,660	3,260	3,050	2,900	2,730	2,600	2,390

in Cubic Feet (ft<sup>3</sup>) per Hour (0.60 Specific Gravity; 3.0 in WC Pressure Drop). Contact your gas supplier for BTU/ft<sup>3</sup> ratings. Use 1,000 BTU/ft<sup>3</sup> for simplified calculations. This table is recommended for supply pressures of 6 in WC or greater.

Pipe Size	Length (including fittings)										
	10 ft (3 m)	20 ft (6 m)	30 ft (9 m)	40 ft (12 m)	50 ft (15 m)	60 ft (18 m)	70 ft (21 m)	80 ft (24 m)	90 ft (27 m)	100 ft (30 m)	125 ft (38 m)
1/2 in	512	3112	150	2212	90	1712	158	117	138	1312	116
3/4 in	919	6512	5112	113	397	360	3312	308	189	173	1112
1 in	1787	1113	986	8112	713	678	6112	580	5112	5112	156
1 1/4 in	3,669	15112	1015	1733	1536	13912	1180	11012	1113	1056	936
1 1/2 in	5,197	3,778	3,0312	1597	13012	1085	1912	1785	1675	15812	11012
2 in	10,588	7,177	5,8112	5,0012	4,133	3,616	3,695	3,137	3,115	3,015	1700
2 1/2 in	16,875	11,598	9,3112	7,9712	7,065	6,1012	5,889	5,179	5,110	1356	1303
3 in	19,8312	10,503	16,165	11,0912	11,189	11,316	10,112	9,685	9,087	8,5812	7,608
4 in	13,678	30,010	11,107	10,6312	8,136	6,569	5,113	11,118	13,305	11,568	11,139

## Maximum Liquefied Propane Delivery Capacity

in Thousands of BTU/H (0.5 in WC Pressure Drop)

Pipe Size	Length (including fittings)												
	10 ft (3 m)	20 ft (6 m)	30 ft (9 m)	40 ft (12 m)	50 ft (15 m)	60 ft (18 m)	80 ft (24 m)	100 ft (30 m)	125 ft (38 m)	150 ft (45 m)	175 ft (53 m)	200 ft (60 m)	250 ft (76 m)
7/8 in	608	608	608	608	608	608	608	608	608	608	608	608	608
3/4 in	608	608	608	608	608	608	608	608	608	608	608	608	608
3/8 in	608	608	608	608	608	608	608	608	608	608	608	608	608
1/2 in	608	608	608	608	608	608	608	608	608	608	608	608	608
3/8 in	608	608	608	608	608	608	608	608	608	608	608	608	608
1/2 in	608	608	608	608	608	608	608	608	608	608	608	608	608

## 5.2 Measuring the Inlet Gas Pressure



### WARNING

The boiler cannot function properly without sufficient inlet gas pressure. Measuring the inlet gas pressure should be performed by a licensed professional only.

- ❑ The inlet gas pressure must be maintained between 3.5 in and 10.5 in WC for natural gas and between 8.0 in and 13.5 in WC for liquefied propane.
- ❑ The appliance and its individual shutoff valve must be disconnected from the gas supply piping system during any pressure testing of that system at test pressures in excess of 7 psi (3.5 kPa).
- ❑ The appliance must be isolated from the gas supply piping system by closing its individual manual shutoff valve during any pressure testing of the gas supply piping system at test pressures equal to or less than 7 psi (3.5 kPa).

To measure the inlet gas pressure:

- 1. Shut off the manual gas valve on the gas supply line.

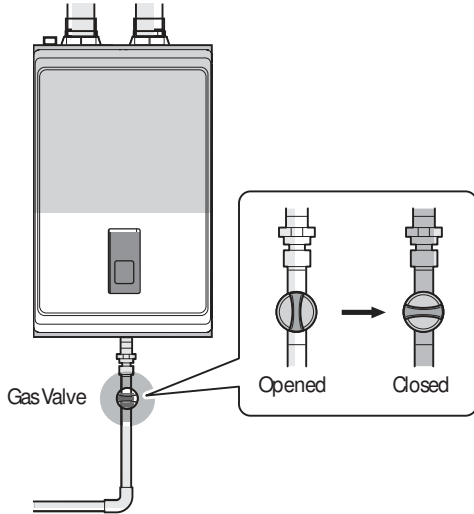

- 2. Open a hot water faucet. The boiler should turn on and the gas in the gas supply line will be purged.
- 3. Leave the faucet on until the boiler shuts down due to a lack of gas supply, and then turn off the hot water faucet.
- 4. Unclasp the 3 buckles that fix the cover to the boiler, and then remove the cover by lifting it and pulling it outward.

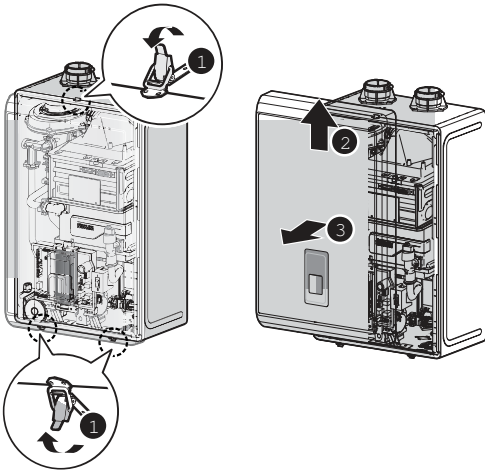

**CAUTION**

Ensure that no cables are in the way before folding down the PCB assembly. If the assembly is stuck, do not force it. Doing so may damage the cables and result in serious malfunctions. Check again to ensure that no cables or any other parts are in the way before you proceed.

- 5. Loosen the screws indicated in the figure below and connect a manometer to the pressure port. Reset the manometer to zero before use.

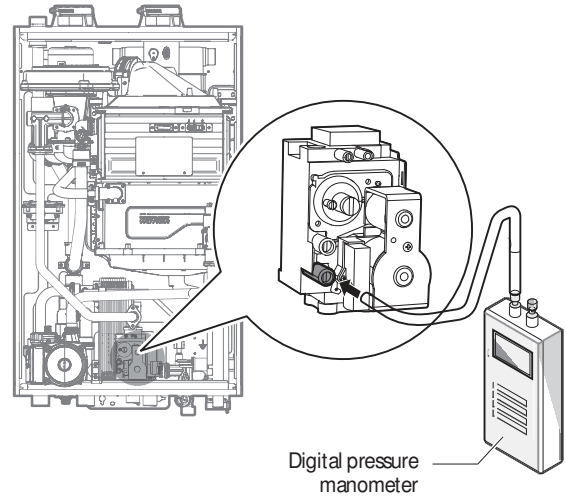

- 6. Re-open the manual gas valve and check for leaks.
- 7. Open multiple fixtures that have high flow rates, such as bathtub and shower faucets, to ramp the boiler up to its maximum firing rate.
- 8. When the boiler reaches its maximum firing rate, check the inlet gas pressure reading on the manometer. The gas pressure must fall within the ranges specified on page 8.

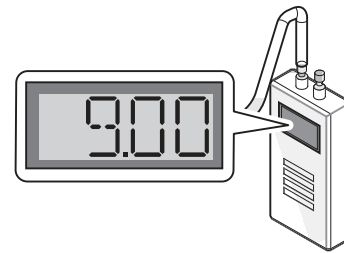

## 6. Venting the Boiler



### WARNING

Improper venting of the boiler can result in excessive levels of carbon monoxide, which can lead to severe personal injury or death. This boiler must be vented in accordance with the “Venting of Equipment” section of the latest edition of the ANSI Z223.1/NFPA 54 Natural Fuel Gas Code in the USA and/or the “Venting systems and air supply for boilers” section of the latest version of the CAN/CGA B149.1 Natural Gas and Propane Installation Code in Canada, as well as all applicable local building codes and regulations. Follow all instructions and guidelines when venting the boiler. Venting should be performed only by a licensed professional.

The boiler must be properly vented to ensure a constant supply of clean intake air and to ensure that exhaust air is properly removed from living areas. When venting the boiler, follow these guidelines:

- ❑ Do not install the boiler in areas with contaminated air (containing a high level of dust, sawdust, sand, flour, aerosols, or any other such airborne contaminants), as contaminants can cause operational problems. The warranty does not cover damage caused by contaminants in the installation area. If you must install the boiler in an area with contaminated air, use direct venting to supply air from outside the building. We recommend regular filter cleaning and maintenance in these areas.
  - ❑ For best results, keep the venting system as short and straight as possible.
  - ❑ Locate the boiler as close as possible to the vent termination.
  - ❑ Do not connect the boiler vent to a vent for any other gas boiler or vent stack.
  - ❑ For horizontal runs, slope the horizontal section upward toward the vent termination at a rate of  $\frac{1}{4}$  in per foot ( $\frac{1}{8}$ % slope).
  - ❑ Create an airtight seal at each joint in the exhaust and intake air pipes from the boiler collar to the vent termination.
  - ❑ To avoid moisture and frost build-up and to maintain clearances to openings on adjacent homes,  $45^\circ$  elbows,  $90^\circ$  elbows, or tees may be attached to the end of the termination vent pipe to direct the exhaust plumes away from buildings, as long as the total allowable vent lengths, maximum number of elbows, and distances to air intake restrictions are observed.
- ❑ Do not store hazardous or flammable substances near the vent termination.
  - ❑ If this boiler will be installed in areas where snow is known to accumulate, protect the vent termination from blockage.
  - ❑ Provide a minimum of  $1\frac{1}{2}$  ft clearance from the bottom of the exhaust above the expected snow accumulation level. Snow removal may be necessary to maintain clearance.
  - ❑ Ensure that the vent termination is at least  $1\frac{1}{4}$  ft (305 mm) above ground,  $1\frac{1}{4}$  ft (300 mm) above the highest anticipated snow level, or as required by local codes, whichever is greater.
  - ❑ Support the vent pipe with hangers at regular intervals or as required by local codes.
  - ❑ Exhaust and intake air pipes must be glued and properly supported at least every  $4\frac{1}{2}$  ft (1.37 m).
  - ❑ The vent for this appliance shall not terminate over public walkways; or near soffit vents or crawl space vents or where condensate or vapor could create a nuisance or hazard or cause property damage; or where condensate or vapor could cause damage or could be detrimental to the operation of regulators, relief valves, or other equipment.

### 6.1 Selecting a Vent Type

All boilers are prepared at the factory to be direct vented (sealed combustion). Navien recommends direct air vent installations whenever possible to avoid back drafting cold air through the boiler unit. If you cannot use a direct vent, ensure that an ample supply of make-up air is available in the installation location.

Navien also recommends installing a new vent system with this appliance. If reusing an existing vent system, thoroughly inspect it for punctures, cracks, or blockages prior to connecting it to the boiler.

#### Direct Venting

The boiler uses  $1\frac{1}{2}$  in or 3 in diameter exhaust and  $1\frac{1}{2}$  in or 3 in diameter intake air ducts. To ensure the draw of air directly from and exhaust of air directly to the outside of the building, create an airtight seal from the boiler collar to the vent termination.

Intake materials can be made of ABS, PVC, CPVC, PP, galvanized steel, corrugated aluminum or any other such materials. If you use a corrugated material, ensure that there is not inadvertent crimping of, or damage to, the intake air pipe.

When using direct venting, maintain the following venting clearances, as required by ANSI Z21.10.3 and the National Fuel Gas Code, ANSI Z223.1/NFPA 54, and CAN/CGA B149.1 Natural Gas and Propane Installation Code:



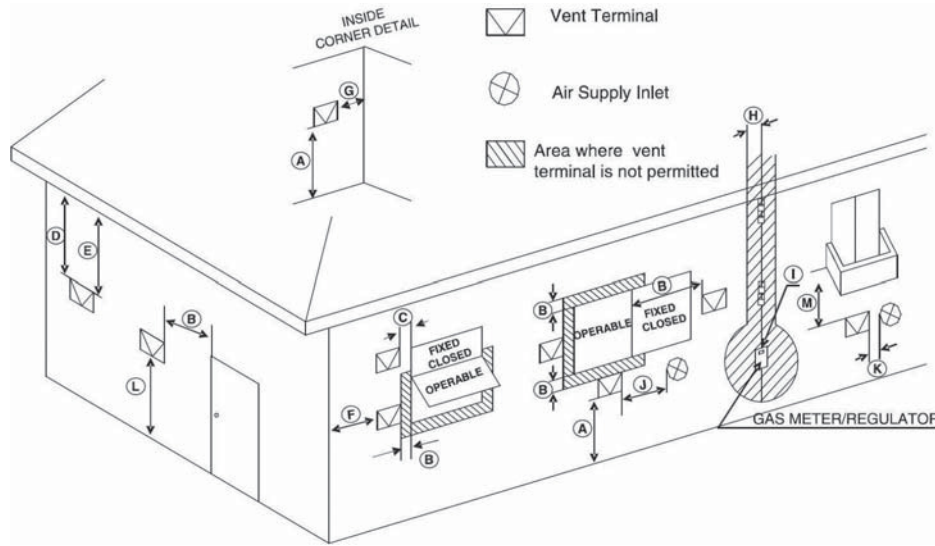

Ref	Description	Canadian Direct Vent Installations <sup>1</sup>	US Direct Vent Installations <sup>2</sup>
A	Clearance above grade, veranda, porch, deck, or balcony	11 in (30 cm)	11 in (30 cm)
B	Clearance to window or door that may be opened	36 in (91 cm)	11 in (30 cm)
C	Clearance to permanently closed window	*	*
D	Vertical clearance to ventilated soffit located above the terminal within a horizontal distance of 6 ft (1.8 m) from the center line of the terminal	*	*
E	Clearance to unventilated soffit	*	*
F	Clearance to outside corner	*	*
G	Clearance to inside corner	*	*
H	Clearance to each side of center line extended above meter/regulator assembly	3 ft (91 cm) within a height 6 ft (1.8 m) above the meter/regulator assembly	*
I	Clearance to service regulator vent outlet	3 ft (91 cm)	*
J	Clearance to nonmechanical air supply inlet to building or the combustion air inlet to any other appliance	36 in (91 cm)	11 in (30 cm)
K	Clearance to a mechanical air supply inlet	6 ft (1.83 m)	3 ft (91 cm) above if within 10 ft (3 m) horizontally
L	Clearance above paved sidewalk or paved driveway located on public property	7 ft (2.13 m) <sup>†</sup>	*
M	Clearance under veranda, porch deck, or balcony	11 in (30 cm) <sup>‡</sup>	*

<sup>1</sup> In accordance with the current CSA B149.1 Natural Gas and Propane Installation Code

<sup>2</sup> In accordance with the current ANSI Z21.51/NFPA 54 National Fuel Gas Code

<sup>†</sup> A vent shall not terminate directly above a sidewalk or paved driveway that is located between two single family dwellings and serves both dwellings.

<sup>‡</sup> Permitted only if veranda, porch, deck, or balcony is fully open on a minimum of two sides beneath the floor.

\* Clearance in accordance with local installation codes and the requirements of the gas supplier.

### Non-Direct Venting (Single Pipe)

If, at any time, the installation location could experience negative pressure, there is a possibility of back drafting cold air through the boiler's heat exchanger. This situation could lead to the freezing of the heat exchanger and malfunction of the boiler.

However, building codes in most jurisdictions disallow negative pressures in residences. In a home with a well-balanced air supply, the heat exchanger should not be in danger of freezing. Because the cause of back drafting is not considered a manufacturing problem, any freezing damage which occurs from back drafting will not be covered by the Navien warranty. If there is any question about the possibility of back drafting in the installation location, use a direct venting system for the boiler.

When using non-direct venting, maintain non-direct vent clearances shown on page 3 as required by ANSI Z21.10.3 and the National Fuel Gas Code, ANSI Z223.1/NFPA 54, and CAN/CSA B149.1 Natural Gas And Propane Installation Code.

To use non-direct venting for the boiler:

- 1. Insert the termination end cap into the intake air duct. Do not glue the end cap, to allow for easy removal and cleaning of the cap.

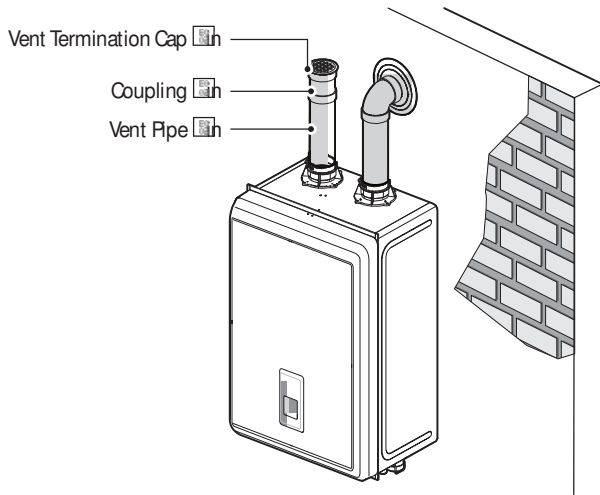

- 2. Provide two openings to allow for circulation of combustion air as specified by ANSI Z21.10.3, NFPA 54 or CAN/CSA B149.1

	Maximum Input (BTU/H)	Outdoor make up air is provided, a minimum free area of 1 in <sup>2</sup> , per 4,000 BTU/H	Indoor make up air is provided, a minimum free area of 1 in <sup>2</sup> , per 1,000 BTU/H
NCB-50E	100,000	30 in <sup>2</sup> 10 in (W) x 3 in (H) or 6 in round	16 in <sup>2</sup> 14 in (W) x 14 in (H)
NCB-80E	50,000	10 in <sup>2</sup> 10 in (W) x 1 in (H) or 7 in round	6 in <sup>2</sup> 14 in (W) x 14 in (H)
NCB-100E	30,000	6 in <sup>2</sup> 10 in (W) x 5 in (H) or 8 in round	7.5 in <sup>2</sup> 14 in (W) x 14 in (H)
NCB-150E	20,000	50 in <sup>2</sup> 10 in (W) x 5 in (H) or 8 in round	9 in <sup>2</sup> 14 in (W) x 14 in (H)

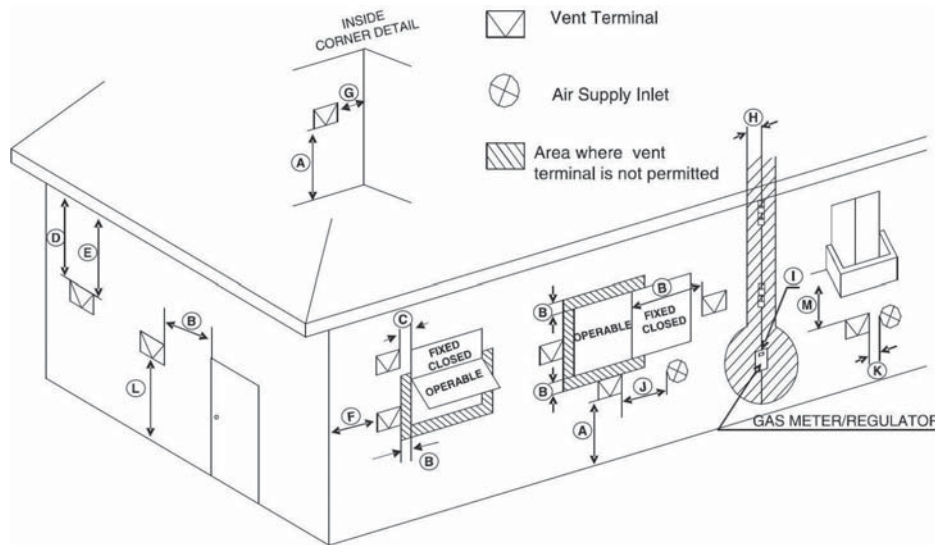

Ref	Description	Canadian Non-Direct Vent Installations <sup>1</sup>	US Non-Direct Vent Installations <sup>2</sup>
A	Clearance above grade, veranda, porch, deck, or balcony	1 ft (30 cm)	1 ft (30 cm)
B	Clearance to window or door that may be opened	36 in (91 cm)	36 in (91 cm) below or to side of opening; 1 ft (30 cm) above opening
C	Clearance to permanently closed window	*	*
D	Vertical clearance to ventilated soffit located above the terminal within a horizontal distance of 6 feet (183 cm) from the center line of the terminal	*	*
E	Clearance to unventilated soffit	*	*
F	Clearance to outside corner	*	*
G	Clearance to inside corner	*	*
H	Clearance to each side of center line extended above meter/regulator assembly	36 in (91 cm) within a height 5 ft (152 cm) above the meter/regulator assembly	*
I	Clearance to service regulator vent outlet	36 in (91 cm)	*
J	Clearance to non-mechanical air supply inlet to building or the combustion air inlet to any other appliance	36 in (91 cm)	36 in (91 cm) below or to side of opening; 1 ft (30 cm) above opening
K	Clearance to a mechanical air supply inlet	6 ft (183 cm)	36 in (91 cm) above if within 30 ft (3 m) horizontally
L	Clearance above paved sidewalk or paved driveway located on public property	7 ft (213 cm)†	*
M	Clearance under veranda, porch deck, or balcony	1 ft (30 cm)‡	*

<sup>1</sup> In accordance with the current CSA B149.1 Natural Gas and Propane Installation Code

<sup>2</sup> In accordance with the current ANSI Z223.1/NFPA 54 National Fuel Gas Code

† A vent shall not terminate directly above a sidewalk or paved driveway that is located between two single family dwellings and serves both dwellings.

‡ Permitted only if veranda, porch, deck, or balcony is fully open on a minimum of two sides beneath the floor.

\* Clearance in accordance with local installation codes and the requirements of the gas supplier.

## 6.2 Selecting Vent Pipe Materials

Venting requirements differ in the US and Canada. Consult the following chart or the most recent edition of ANSI Z111.1 NFPA 51 or CAN/CGA B149.1, as well as all applicable local codes and regulations when selecting vent pipe materials. Do not use cellular core PVC (ASTM F891), cellular core CPVC, Padel® (polyphenolsulfone) for the exhaust vent.

Locale	Recommended Vent Materials
USA	<ul style="list-style-type: none"> <li>☐ PVC Schedule 40 (Solid Core)</li> <li>☐ CPVC Schedule 40 or 80 (Solid Core)</li> <li>☐ Approved Polypropylene*</li> </ul>
Canada**	<ul style="list-style-type: none"> <li>☐ Type BH Special Gas Vent Class IIA (PVC)</li> <li>☐ Type BH Special Gas Vent Class IIB (CPVC)</li> <li>☐ Type BH Special Gas Vent Class IIC (Polypropylene)</li> </ul>

\* Approved polypropylene systems include:  
 Duravent Polypro (Single Wall): 3PPS-xxx (3")  
 Centrotherm InnoFlue SW: ISxx03xx (3")  
 Refer to manufacturer's literature for detailed information.

For 3" venting, use the following polypropylene parts:  
 Duravent  
 3PPS-X3L (3" 3" Increaser)  
 Centrotherm  
 ISE03B or ISIA03B (3" 3" Increaser)

\*\* For installation in Canada, field-supplied plastic vent piping must comply with CAN/CGA B149.1 (latest edition) and be certified to the Standard For Type BH Gas Venting Systems, ULC-S636. Components of this listed system must not be interchanged with other vent systems or unlisted pipes or fittings. All plastic components and specified primers and glues of the certified vent system must be from a single system manufacturer and must not be intermixed with another system manufacturer's parts. The supplied vent connector and vent termination are certified as part of the boiler.

### ⚠ CAUTION

- ☐ This boiler has a built-in control to limit the exhaust temperature to 160°F (65°C). As a result, the boiler can be vented with Schedule 40 PVC.
- ☐ In high temperature applications, the exhaust temperature can exceed 160°F (65°C). In that case, you must use Schedule 40 or 80 CPVC or Approved Polypropylene in the USA or Type BH Special Gas Vent Class IIB (CPVC) or Class IIC (Polypropylene) that conforms to ULC-S636 in Canada.
- ☐ In systems with 3 in. vents, if the exhaust temperature exceeds 160°F (65°C), CPVC pipe (field supplied) must be used for the first 3 feet of equivalent pipe length. For systems with 3 in. vents, if the exhaust temperature exceeds 160°F (65°C), CPVC pipe (field supplied) must be used for the first 5 in. of equivalent pipe length.

If you require that return water hotter than 160°F (60°C) to circulate back to boiler, the DIP switch must be configured (Dip Switch 2, switch #8 to ON position). Otherwise, the boiler will control and maintain the flue and DHW temperature below 150°F (65°C) and 160°F (60°C) respectively.

### Note

- ☐ When PCB DIP switch #8 is set to Off (factory default), the boiler does not operate without an exhaust thermostat installed.
- ☐ When you set PCB DIP switch #8 to On, ensure that CPVC piping is used for exhaust venting.

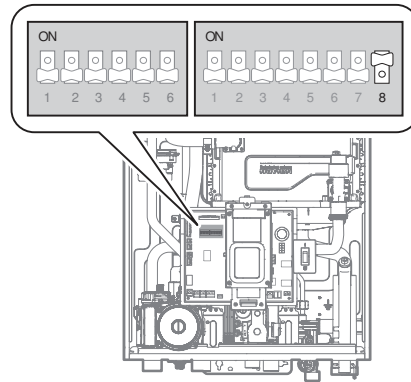

### 6.3 Measuring Vent Length

The maximum vent length when using 4 in exhaust ducts is 60 ft (18 m). The maximum vent length when using 3 in vent ducts is 50 ft (15 m). The intake duct length may be identical to the exhaust duct length. Maximum vent lengths reduces according to the number of elbows used, as shown in the following table:

Vent Size	Maximum Length	Maximum # of Elbows	Equivalent Length
4 in.	60 ft (18 m)	6	Reduce the maximum vent length accordingly for each elbow used: □ Each 90° elbow equates to 8 linear feet of vent □ Each 45° elbow equates to 4 linear feet of vent
3 in.	50 ft (15 m)	8	Reduce the maximum vent length accordingly for each elbow used: □ Each 90° elbow equates to 5 linear feet of vent □ Each 45° elbow equates to 3 linear feet of vent

**Note**

- The Maximum Length does not include any elbows.
- If using a concentric termination as shown on page 16, count this as 5 linear feet (1.5 m) of vent.

### 6.4 Terminating the Vent

Before installing the boiler, determine what type of vent termination is appropriate for the installation location and situation. The subsections that follow describe some typical venting configurations, but do not include all possible options.

The following PP components can be used as terminations:

- Duravent  
 1PPS-E90L (1 90° Elbow)  
 3PPS-E90L (3" 90° Elbow)  
 1PPS-E45L (1 45° Elbow)  
 3PPS-E45L (3" 45° Elbow)  
 1PPS-TL (1 Tee)  
 3PPS-TL (3" Tee)  
 1PPS-BG (1 Birdscreen)  
 3PPS-BG (3" Birdscreen)
- Centrotherm  
 ISELL0387 (1 87° Elbow)  
 ISELL0387 or ISELL0387 (3" 87° Elbow)  
 ISELL0345 (1 45° Elbow)  
 ISELL0345 or ISELL0345 (3" 45° Elbow)  
 IST01 (1 Tee)  
 IST03 (3" Tee)  
 IASPP01 (1 Birdscreen)  
 IASPP03 (3" Birdscreen)

Along with 4 in and 3 in PVC concentric terminations shown on page 16, the following terminations can also be used:

- IPEX Low Profile Termination Kits:  
 4 in Low Profile Vent Kit #16698  
 3 in Low Profile Vent Kit #16695
- Duravent PolyPro Horizontal Concentric Termination Kit  
 4 in x 4 in Concentric Vent Kit #1PPS-HKL  
 3 in x 5 in Concentric Vent Kit #3PPS-HKL

Refer to the vent manufacturer's instructions for detailed installation procedures.

**! CAUTION**

- Minimum Clearance to Metering devices and Relief equipment. Maintain a minimum horizontal clearance of 1 ft (0.3 m) from electric meters, gas meters, regulators, and relief equipment. Do not install the boiler above or below electric meters, gas meters, regulators, or relief equipment unless a 1 ft (0.3 m) horizontal clearance is maintained.
- Refer to the figure below for the orientation of vent termination if the IPEX low profile vent kit is used for termination.

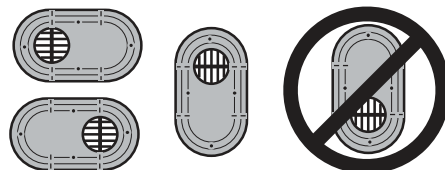

## Indoor Boiler Installation Venting Examples

The following are some possible indoor venting options:

- 1. 12" or 3 in Two-pipe Sdewall Venting

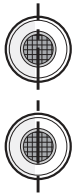
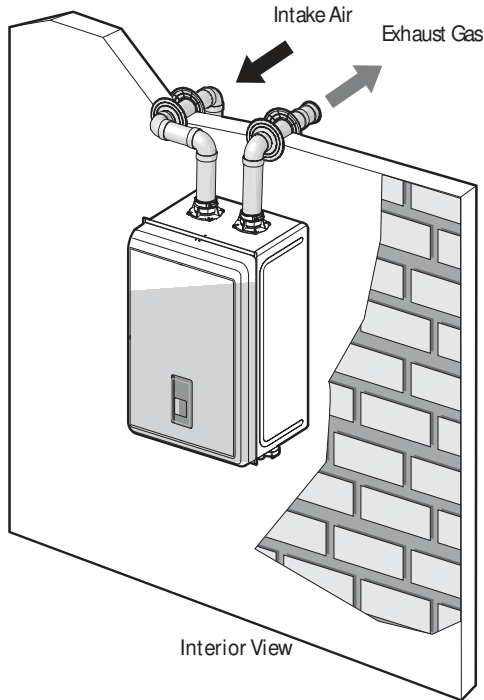

Do not vertically stack terminations on sidewalls.

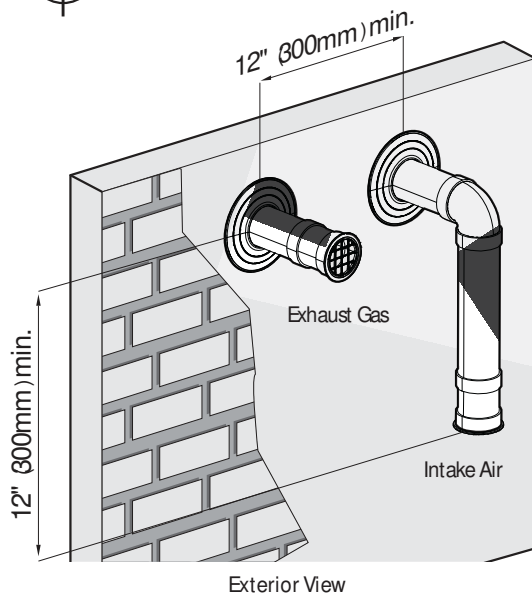

- 2. Non-concentric Sdewall Venting – Air is drawn from a different location that is at least 12" (300 mm) away from the exhaust termination. Try to minimize the length of the intake air pipe with this venting.

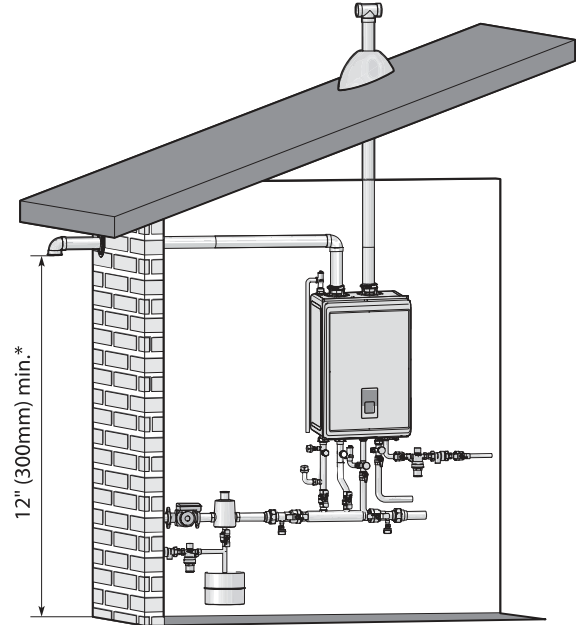

\* 12" (300mm) above the highest anticipated snow level, or as required by local codes, whichever is greater

- 3. Concentric Sdewall Venting

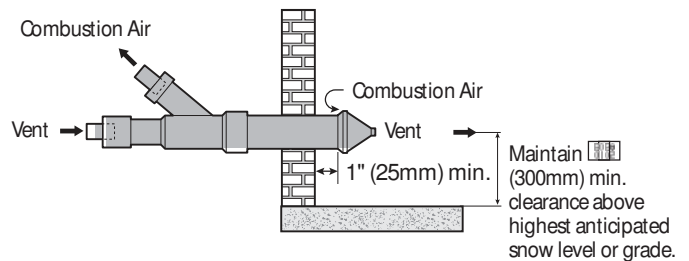

- 1 in or 3 in Two-pipe Vertical Venting – Intake and exhaust pipes do not have to terminate in the same area.

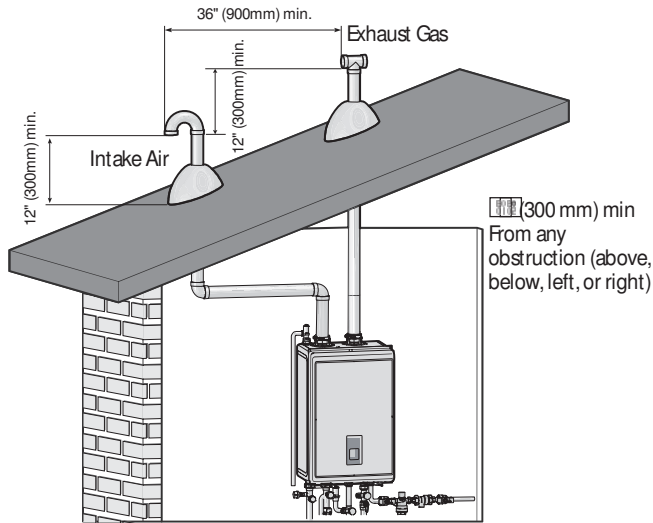

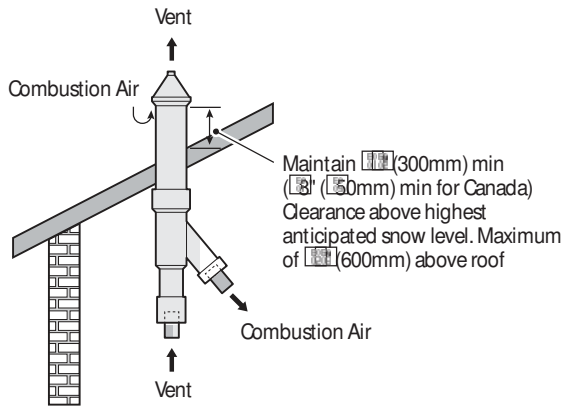

- Concentric Roof Venting



## 7. Setting the DIP Switches

### CAUTION

Do not remove the front cover unless the power to the boiler is turned off or disconnected. Failure to do so may result in electric shock.



The boiler has  sets of DIP switches on the main circuit board (PCB) and  sets of DIP switches on the front panel. DIP switches are used to control the functionality of the boiler. Set the DIP switches appropriately, based on the installation environment.

### 7.1 PCB DIP Switches



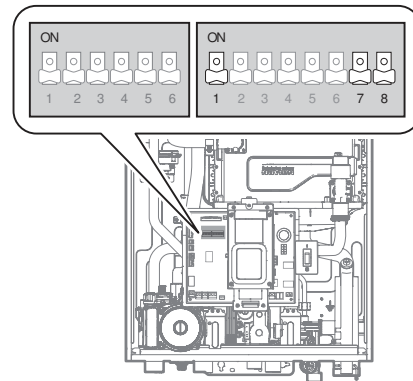

#### Dip Switch 2 (Set of 8)

The DIP SW  on the circuit board configures additional features at the time of installation, such as temperature control modes.



Switch	Function	Setting	
	Temperature Control	Return Water	
		Supply Water	
7	Thermostat or Zone Controller	Unused (Permanent Space Heating Demand)	7-ON
		Used	7-OFF
8	Exhaust Thermostat	Temperature Limit Unused (CPVC)	8-ON
		Setting (PVC)	8-OFF

#### Note

-  When PCB DIP switch  is set to Off (factory default), the boiler does not operate without an exhaust thermostat installed.
-  When you set PCB DIP switch  to On, ensure that CPVC piping is used for exhaust venting.



## 7.2 Front Panel Dip Switches

### Dip Switch 1 (Set of 10)

The DIP SW 1 on the front panel configures the temperature unit, well pump, high altitude settings, and lime alarm cycle (for slave units).

Before changing the settings, lift the rubber cover to access the front panel DIP switches.

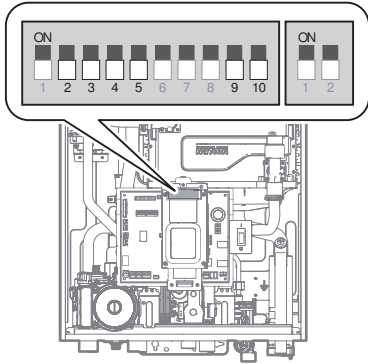

Switch	Function	Setting	
1	Temperature Unit	°C (Celsius)	ON
		°F (Fahrenheit)	OFF
3	Well Pump	On	3-ON
		Off	3-OFF
4 & 5	High Altitude*	0-3,999 ft (0-609 m)	OFF, 5-OFF
		4,000-5,399 ft (609.6-815 m)	ON, 5-OFF
		5,400-7,699 ft (815.3-1158 m)	OFF, 5-ON
		7,700-10,000 ft (1158.7-3,078 m)	ON, 5-ON
9 & 10	Lime Alarm**	Unused	9-OFF, 10-OFF
		6 months	9-ON, 10-OFF
		12 months	9-OFF, 10-ON
		18 months	9-ON, 10-ON

\* Above 4,000 ft (609 m), the boiler will derate by 1% for each 1,000 ft (305 m) of altitude gain.

\*\* Sets the lime alarm cycle of the slave units when a cascade configuration is in use.

#### Note

This boiler may be installed at elevations up to 10,000 ft (3,078 m) for use with Natural Gas and 8,500 ft (2,591 m) for use with Propane. To use the boiler at a specific altitude, the DIP switches should be set as described above.

### Dip Switch 2 (Set of 2)

The DIP SW 2 on the front panel configures the cascade vent and gas type settings.

Before changing the settings, lift the rubber cover to access the front panel DIP switches.

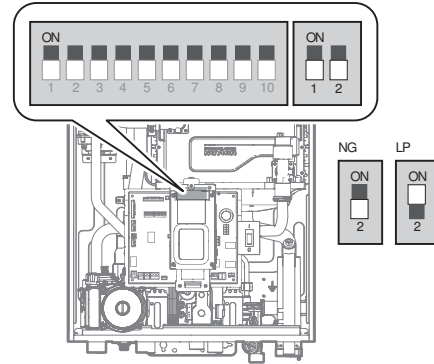

Switch	Function	Setting	
1	Cascade Vent	Common Vent	OFF
		Individual Vent	ON
2	Gas Type	Natural Gas	OFF
		Propane Gas	ON

## 8. Connecting the Power Supply



### WARNING

Improperly connecting the power supply can result in electrical shock and electrocution. Follow all applicable electrical codes of the local authority having jurisdiction. In the absence of such requirements, follow the latest edition of the National Electrical Code (NFPA 70) in the USA or the latest edition of CSA C22.1 Canadian Electrical Code Part 1 in Canada. Connecting the power supply should be performed only by a licensed professional.

When connecting the power supply, follow these guidelines:

- ❑ Do not connect the electric supply until all plumbing and gas piping is complete and the boiler has been filled with water.
- ❑ Do not connect the boiler to a 120-240V AC power supply. Doing so will damage the boiler and void the warranty.
- ❑ All the Navien NCB-E boilers come with a factory-installed, 3-pronged (grounded) plug. The boiler can be plugged into any grounded electrical outlet nearby, as it requires only 15 Amps. It is not necessary to run a dedicated electrical line to the boiler.
- ❑ If local codes require the boiler to be wired directly, remove and discard the factory-installed plug. Install a power switch between the breaker and the boiler to facilitate end-user maintenance and servicing. Connect the boiler to a 120-240V AC at 60 Hz with a maximum of 15A.
- ❑ The boiler must be electrically grounded. If using the power plug, ensure that the electrical outlet you connect the boiler to is properly grounded. If wiring the boiler directly to a power supply, do not attach the ground wire to either the gas or the water piping as plastic pipe or dielectric unions may prevent proper grounding.

- ❑ We recommend using a surge protector to protect the boiler from power surges.
- ❑ If there is a power failure in cold weather areas, the freeze prevention system in the boiler will not operate and may result in freezing of the heat exchanger. In cold weather areas where power failures are common, you must completely drain the boiler to prevent damage if the power will be off for any extended period of time. A battery back-up (available at most computer retailers) may be used to supply hot water during periods of power outages. Damage caused by freezing is not covered under warranty.



### CAUTION

Label all wires before disconnecting them when you work on the controls. Wiring errors can cause improper and dangerous operation. Verify proper operation after servicing.

## 9. Installation Check list

After installing the boiler, review the following checklist. You should be able to answer “Yes” to all of the items in the checklist. If not, review the appropriate sections to complete the installation. To troubleshoot any operational problems refer to “Troubleshooting” in the Owner’s Manual.

If you have additional questions or need assistance with installation, contact Technical Support at 800-591-8791 or 99-00-0110, or refer to the technical support section of Navien’s website (www.navien.com).

Installing the boiler	Yes	No
Have you maintained the required clearances from building openings and intake air vents?		
Have you minimized the distance between the boiler and the vent termination?		
Have you minimized the distance between the boiler and major fixtures?		
Have you maintained the proper service and maintenance clearances?		
Is the make-up air supply sufficient for proper operation?		
Is the make-up air supply free from dust, dirt, corrosive elements, and flammable vapors?		
Is the boiler and vent piping clear of combustibile materials, including clothing, cleaning materials, and rags?		

Connecting the Gas Supply	Yes	No
Does the gas supply match the type specified on the boiler’s rating plate?		
Is the gas line at least $\frac{7}{8}$ or $\frac{3}{4}$ in ID (Inner Diameter)?		
Is the gas supply line sufficient in length and diameter to deliver the required BTUs?		
Have you measured the pressure of the gas supply line?		
Is the gas supply pressure within the recommended ranges specified in this manual?		
Is the gas supply line equipped with a manual shut-off valve?		
Have you tested the gas line pressure and all fittings for leaks?		
Has the gas company inspected the installation, if required?		

Connecting the Domestic Water Supply	Yes	No
Is the water supply pressure sufficient (greater than 10 psi)?		
Have you installed shut off valves on the inlet and outlet to facilitate cleaning of the inlet water filter?		
Have you bled the air out at each fixture?		
Have you checked each fixture to ensure hot water is being supplied?		
Have you cleaned the inlet water filter?		
If you installed a recirculation line, have you insulated the hot water pipes and the return line?		

Connecting the Space Heating Piping	Yes	No
Has the system been filled (less than 30 psi) and purged of air?		
Does the piping incorporate means for air removal (scoop, separator, etc.)?		
Is there an expansion tank installed and set to the proper system pressure?		
If antifreeze has been used, is it the proper type and is the concentration appropriate?		
If an external low water cut off (LWCO) is installed, is it wired to the boiler?		

Connecting a Pressure Relief Valve	Yes	No
Have you installed an approved pressure relief valve on the boiler?		
Does the rating of the pressure relief valve match or exceed the maximum BTU rating of the boiler?		
Is the pressure relief valve $\frac{3}{4}$ " on the hot water outlet and $\frac{3}{4}$ " on the space heating outlet?		
Have you installed the pressure relief valves to the pressure relief valve adapter, and on the space heating pipe near the boiler?		
Have you installed a discharge drain tube from the pressure relief valve to within 6" (150-300 mm) of the floor?		

Connecting the Condensate Drain	Yes	No
Have you installed a condensate drain line from the boiler to a drain or laundry tub?		

Venting the boiler	Yes	No
Have you vented the boiler with $\frac{1}{2}$ " or 3" in PVC, CPVC, Polypropylene, Type BH Special Gas Vent (ULC-S636) for Category IV boilers (Canada), or in accordance with all local codes and the guidelines in this manual?		
Have you ensured that ABS or PVC cellular core pipe has not been used as venting for the boiler?		
Is the vent sloped upward toward the vent termination at a rate of $\frac{1}{4}$ " per foot ( $\frac{1}{4}$ % grade)?		
Are all vent runs properly supported?		
Have you properly supported the vent termination?		
Have you properly sealed all air intake and exhaust joints, from the flue collar to the vent termination?		
Have you installed end caps on the exhaust and intake pipes?		
Have you checked the venting for leaks?		
Is the vent termination at least 3" (300mm) above the exterior grade?		
Have you ensured that sufficient make-up air is available?		
Is the total vent length within the maximum vent length restriction?		

Connecting the Power Supply	Yes	No
Is the supplied voltage 120-240V AC?		
Is the boiler plugged into a properly grounded outlet?		
If you have made a direct power supply connection, have you installed a power switch to facilitate end-user maintenance?		
Have you checked the polarity of the electrical connection?		
Is the system properly set up for cascading operation (master and slave boilers), if applicable?		

PCB DIP switch setting (DIP SW 2, set of 8)	Yes	No
Is switch #1 set correctly for Return Water Control (ON) or Supply Water Control (OFF)?		
If continuous boiler operation is required, is switch #7 in the up (ON) position?		
If high temperature venting has been installed (CPVC or polypropylene), is switch #8 in the up (ON) position?		

Front Panel DIP switch setting (DIP SW 1, set of 10)	Yes	No
Is switch #1 set correctly for Celsius (ON) or Fahrenheit (OFF)?		
Unless using the well pump, is switch #3 set in the down (OFF) position?		
Is switch #8 set correctly for the installation altitude?		

Front Panel DIP switch setting (DIP SW 2, set of 2)	Yes	No
Is switch #1 set correctly for natural gas (OFF) or propane gas (ON)?		

Operating the boiler	Yes	No
Have you shown the owner how to clean the inlet water filter?		
Have you given the Installation & Operation Manual and User's Information Manual to the owner for future reference?		
Have you shown the owner how to shut off the gas in case of an emergency?		

## 10. Operating the Boiler

### 10.1 Turning the Boiler On or Off

To turn the boiler on or off, press the Power button for 0.3 seconds.

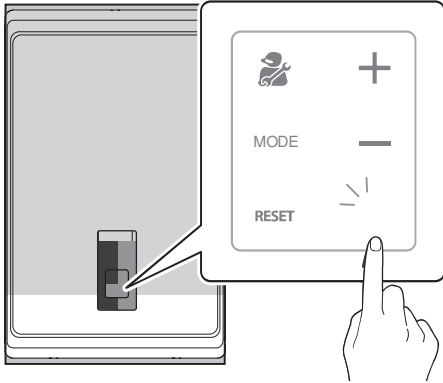

When the power is on, the water temperature of the space heating supply will appear with the water pressure on the front panel display in 5 second intervals.

#### Note

- ▣ If the Air purge is operating, "Air" will appear with the water pressure on the front panel display in 5 second intervals.
- ▣ When displaying the water temperature of the space heating supply, the supply or return water icon flashes, depending on the space heating control mode.

### 10.2 Adjusting the Temperature

#### 10.2.1 Adjusting the Space Heating Temperature

To adjust the heating temperature:

- ▣ Press the Mode button once. The space heating icon turns on.

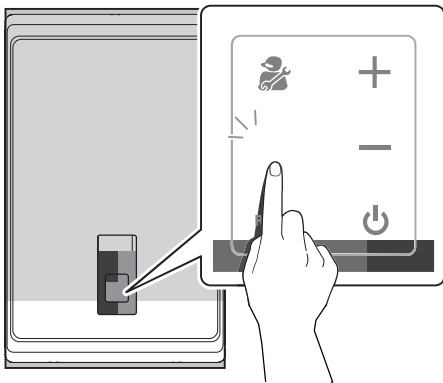

- ▣ Press the + (Up) or - (Down) buttons until the desired temperature appears on the display.

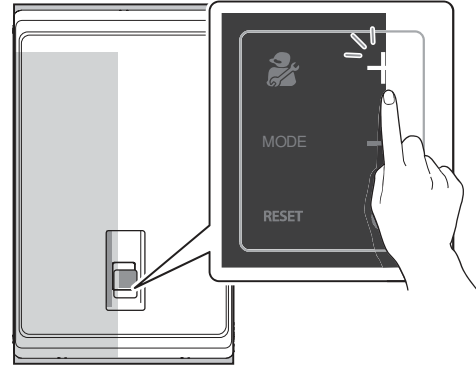

You can adjust the temperature while the display is flashing. Once the display stops flashing, the temperature setting is stored.

#### Note



- ▣ Take note of the original heating temperature in case you want to restore it to the default.
- ▣ The default space heating supply water temperature range is 60.3°F (16°C, Absolute MIN) to 80°F (26.7°C, Absolute MAX).
- ▣ The default space heating return water temperature range is 86°F (30°C, Absolute MIN) to 109°F (42.8°C, Absolute MAX).
- ▣ You can adjust the temperature range in the parameter settings menu.
- ▣ The boiler will retain your settings during a power outage.

## 10.2.2 Adjusting the DHW Temperature

### WARNING





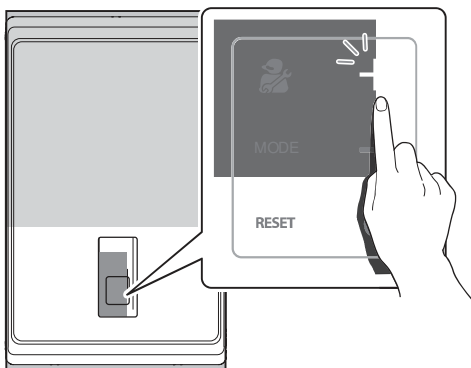

Before adjusting the water temperature, read “To prevent burns.” on page 6 carefully. Water above 110°F (50°C) can cause instant scalding, severe burns, or death.

To adjust the water temperature:

1.  Make sure that all hot water faucets are closed, and ensure that the internal circulator and any external circulating pumps are off.
2.  Press the Mode button twice. The DHW mode icon turns on.
3. Press + (Up) or – (Down) buttons until the desired temperature appears on the display.



You can adjust the temperature while the display is flashing. Once the display stops flashing, the temperature setting is stored.

Temperature range	Adjusting the water temperature
86-110°F (Fahrenheit mode) 30-50 °C (Celsius mode)	 For  increments
 -  F (Fahrenheit mode) 50-60 °C (Celsius mode)	Press for  seconds to adjust in 5°F or  increments

#### Note





The boiler will retain your settings during a power outage.

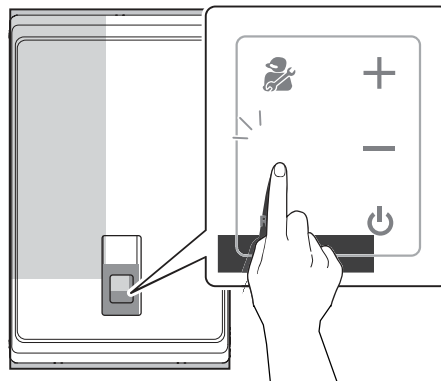

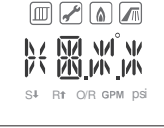

## 10.3 Viewing Basic Information

To view information about the boiler, press the Mode button three times. “INFO” will appear on the display.



Press the + (Up) or – (Down) buttons to switch between the information types.

Display	Description
	Space heating supply water temperature (°F)
	Space heating return water temperature (°F)
	Domestic hot water outlet temperature (°F)
	Cold water inlet temperature (°F)
	Domestic hot water (DHW) flow rate in GPM

Display	Description
	Outdoor air temperature (°F) (with optional Outdoor Temperature Sensor only)
	Outdoor reset curve -: Not in use. <input type="checkbox"/> Finned tube baseboard <input type="checkbox"/> FAN coil <input type="checkbox"/> 3: Cast iron baseboard <input type="checkbox"/> Low mass radiant <input type="checkbox"/> 5: High mass radiant <input type="checkbox"/> 6: Radiator <input type="checkbox"/> 7: Custom (set by installer)
	Boost interval time (set by installer)
	Space heating water pressure in PSI

To exit information mode, press the **Reset** button.

## 10.4 Setting the Operation Mode

- Using the Front Panel, press and hold the **Diagnostics Button** for over 5 seconds until “**PAR**” is displayed.

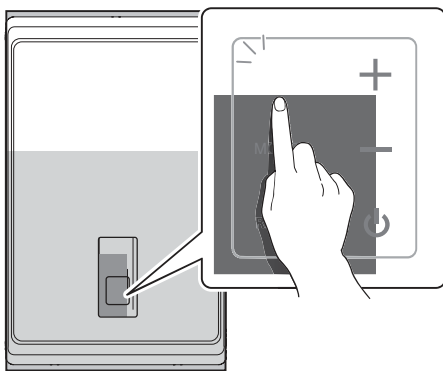

- Press the **+** (Up) button two times to change the display to “3.OPP”.
- Press the **Mode Button** once to access the Operation Mode menu.
- Press the **+** (Up) button once to set the boiler to operate at **Stage MIN** (“MIN.”).
- To set the boiler to operate at **DHW Stage MAX**, press the **+** (Up) button until “D.MX.” is displayed.
  - To exit the Operation Mode setting and return the boiler to normal operation, press the **Reset** button twice.

## 10.5 Setting the Parameters

You can modify parameter settings for boiler operations, such as the space heating and DHW temperature ranges, in different operating conditions. Follow the instructions below to enter the **Special Parameter mode** and change parameter settings.

### ! CAUTION

Parameters must be set by a qualified professional with an extensive understanding of the boiler system. Setting parameters improperly may lead to property damage or injury.

- Press and hold the **Diagnostic button** for 5 seconds to enter the **Special Parameter mode**.

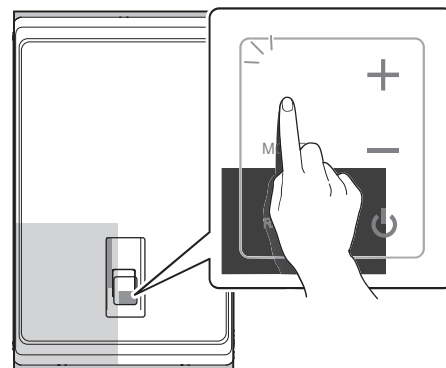

- Press the **+** or **-** buttons to move to “**PAR**” (Parameter Setting mode), and then press the **Mode button**. You will be asked to enter a password (“**PASS**” is displayed). The factory default password is “1111”.



3. Press the Mode button and enter your 4-digit password. Use the + or – buttons to increase or decrease numbers and the Diagnostic button to move between digits.

When you are done, press the Mode button.

5. Press the + or – buttons to move to a parameter setting, and then press the Mode button to enter the Parameter Edit mode.

6. Press the + or – buttons to change the parameter value.



7. When you are done, press the Mode button to save the settings.

8. To exit the Special Parameter mode, press the Reset button twice.

**Note**

- ❑ If you enter an incorrect password 10 times or make no inputs within 5 minutes, the boiler will return to the Normal mode.
- ❑ To return to the previous mode, press the Reset button.
- ❑ The Factory default password is “1234”.
- ❑ If you make no inputs for 10 seconds in the Parameter Edit mode, the current parameter value will be saved automatically.
- ❑ Press and hold the Reset button in Parameter Edit mode for 5 seconds to reset individual parameters to their default values.
- ❑ When you reset one of the following parameters, the corresponding parameter will be reset automatically:
  - Supply absolute MIN or MAX
  - Return absolute MIN or MAX
  - Lowest Outdoor Temperature or Highest Outdoor Temperature

Configuring the Outdoor Reset Control Mode

Display	Description
	Outdoor Reset enabled
	Outdoor Reset disabled

This mode is used to configure the Outdoor Reset Control mode. This mode is disabled by default from the factory.



**CAUTION**

An outdoor sensor error may occur if the Outdoor Reset Control mode is enabled without the outdoor sensor installed

**Note**

In the Outdoor Reset Control mode, the boiler’s water temperature is regulated according to the outdoor temperature. The Outdoor Reset Control operation ensures that the system provides optimal space heating. It helps limit the cost for space heating by preventing unnecessary fuel consumption and minimizes air pollution.

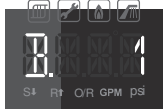
Setting the Heat Load for the Outdoor Reset Control Mode

Display	Description
	Outdoor Reset heat load types 1: Finned tube baseboard 2: FAN coil 3: Cast iron baseboard 4: Low mass radiant 5: High mass radiant 6: Radiator 7: Custom
	Outdoor Reset heat load not selected

This mode is used to configure the heat load type to be used with the Outdoor Reset Control mode.

A preset or user-defined temperature range is selected automatically based on the heat load type selected.

### Types of Heat Load

Heat Load	Supply Set-point Range	Return Set-point Range	Remarks
Finned Tube Baseboard	60-80°F (15.5-26.5°C)	60-67°F (15.5-19.5°C)	Default
Fan Coil	60-80°F (15.5-26.5°C)	65-67°F (18.5-19.5°C)	
3. Cast Iron Baseboard	60-70°F (15.5-20.5°C)	86-69°F (30-19.5°C)	
Low Mass Radiant	80-110°F (26.5-43°C)	70-115°F (21-46.5°C)	
5. High Mass Radiant	80-110°F (26.5-43°C)	70-101°F (21-38°C)	
6. Radiators	60-70°F (15.5-20.5°C)	60-69°F (15.5-19.5°C)	
7. Custom	Supply Control: Absolute MIN/ MAX Set-point	Return Control: Absolute MIN/ MAX Set-point	User-defined

Heat loads show the preset temperature ranges based on the load type selected, while heat load 7 provides a custom temperature range. When the custom temperature range is in use, the boiler operates based on the user-defined “Absolute Min” and “Absolute Max” temperature settings.

### Setting the Lowest Outdoor Temperature

Display	Description
	Lowest outdoor temperature (°F)
	Lowest outdoor temperature not in use

This mode is used to configure the lowest outdoor temperature. The boiler will operate at the high end of the supply or return set-point range at this outdoor temperature.

### Outdoor Low Temperature Setting Range

Range	Remarks
-9°F (-10°C) ~ [Outdoor High Temperature Set-point - 9°F (5°C)]	Default: 65°F (-10°C)

### Setting the Highest Outdoor Temperature

Display	Description
	Highest outdoor temperature (°F)
	Highest outdoor temperature not in use

This mode is used to configure the highest outdoor temperature. The boiler will operate at the low end of the supply or return set-point range at this outdoor temperature.

### Outdoor High Temperature Setting Range

Range	Remarks
[Outdoor Low Temperature Set-point + 9°F (5°C)] ~ 101°F (38°C)	Default: 70°F (21°C)

### Setting the Boost Interval Time

Display	Description
	Boost interval time (min)

The boost interval time may be set to prevent interruption in space heating while using the Outdoor Reset Control mode, due to changes in heat load conditions. With the boost interval time enabled, the boiler increases the space heating supply temperature by 9°F (5°C) and the return temperature by 5°F (3°C) after a set time elapses.

#### Boost Interval Time and Temperature Setting

Setting	Range	Remarks
Boost Interval Time	OFF (0), 1-10 min	Default: OFF (0)
Boost Temperature	Space Heating Supply (Fixed Value): 9°F (5°C)	
	Space Heating Return (Fixed Value): 5°F (3°C)	

### Setting the Max Heat Capacity for Space Heating

Display	Description
	Space heating max heat capacity (%)

This menu is used to configure the desired space heating capacity. When the boiler operates in the Normal mode, the space heating capacity is limited to the set value (%).

- ☐ Default: 100%
- ☐ Setting Range: 50-100%

### Setting the Pump Freeze Protection Temperature

Display	Description
	Pump freeze protection temperature (°F)

This menu is used to configure the circulation pump freeze protection temperature.

When the space heating supply temperature stays below the set value for longer than 10 seconds, the boiler runs the circulation pump to prevent freeze damage (the pump runs for 10 minutes, then stops for 1 minute).

- ☐ Default: 50°F (10°C)
- ☐ Setting Range: 3-50°F (6-10°C)

### Setting the Anti-fast Cycling Time

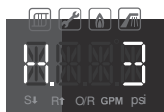
Display	Description
	Anti-fast cycling time (min)

The anti-fast cycling time is the duration that the boiler stops its space heating operation when the space heating supply or return temperatures reach the set values for boiler operation stop temperatures. The boiler will not resume space heating until the duration elapses, even when the space heating supply or return temperatures return to within the set ranges.

- ☐ Default: 3 minutes
- ☐ Setting Range: 0-10 minutes

### Setting the Pump Overrun Time

Display	Description
	Pump overrun time (min)

The pump overrun time is the duration that the circulation pump will continue to run when the space heating supply or return temperatures reach the set values for boiler operation stop temperatures and the burner turns off. If the space heating supply or return temperature remains out of the boiler operation temperature range after the set time, the boiler stops the pump for 10 minutes, runs it again for 5 minutes, and then repeats the cycle.

- ☐ Default: 10 minutes
- ☐ Setting Range: 3-10 minutes

### Setting the DHW Max Heat Capacity

Display	Description
	DHW max heat capacity (%)

This menu is used to configure the desired DHW capacity. When the boiler operates in the Normal mode, the DHW capacity is limited to the set value (%).

- ☐ Default: 100%
- ☐ Setting Range: 50-100%

### Setting the DHW Wait Time

Display	Description
	DHW wait time (min)

The DHW wait time is the duration that the boiler maintains the DHW supply mode after a DHW demand. With the DHW wait time enabled, a faster DHW supply may be available when there is a subsequent DHW demand. The boiler switches the 3-way valve to space heating mode when the set time elapses.

- ☐ Default: 5 minutes
- ☐ Setting Range: 0-10 minutes

### Note

When a call for space heating occurs simultaneously with a DHW demand, the 3-way valve will immediately switch to space heating mode at the end of the DHW demand.

### Setting the Burner-Off Temperature

Display	Description
	Burner-off temperature (°F)

During space heating, the boiler turns off the burner when the space heating supply temperature meets or exceeds the burner-off temperature.

### Burner-Off Temperature Range

Range	Remarks
0-5°F (0-30°C)	Default: 4°F (10°C)

### Setting the Burner-On Temperature

Display	Description
	Burner-on temperature (°F)

During space heating, the boiler turns on the burner when the space heating supply temperature is below the burner-on temperature.

### Burner-On Temperature Range

Range	Remarks
5-5°F (3-30°C)	Default: 5°F (3°C)

Setting the Supply Absolute MAX Temperature

Display	Description
	Supply absolute MAX set point (°F)

This menu may be used to make changes to the maximum supply temperature range when the Supply Control mode is in use. When configuring the Custom mode in the Outdoor Reset Control mode, the supply temperature changes based on the supply absolute MAX temperature range.

Supply Absolute MAX Temperature Range

Range	Remarks
[MIN Set-point + 36°F (10°C)] ~ 191°F (90°C)	Default: 180°F (82°C)

Setting the Supply Absolute MIN Temperature

Display	Description
	Supply absolute Min set point (°F)

This menu may be used to make changes to the minimum supply temperature range when the Supply Control mode is in use. When configuring the Custom mode in the Outdoor Reset Control mode, the supply temperature changes based on the supply absolute MIN temperature range.

Supply Absolute MIN Temperature Range

Range	Remarks
77°F (25°C) ~ [MAX Set-point - 36°F (10°C)]	Default: 104°F (40°C)

Setting the Return Absolute MAX Temperature

Display	Description
	Return absolute MAX set point (°F)

This menu may be used to make changes to the maximum return temperature range when the Return Control mode is in use. When configuring the Custom mode in the Outdoor Reset Control mode, the return temperature changes based on the return absolute MAX temperature range.

Return Absolute MAX Temperature Range

Range	Remarks
[MIN Set-point + 8°F (10°C)] ~ 158°F (70°C)	Default: 149°F (65°C)

Setting the Return Absolute MIN Temperature

Display	Description
	Return absolute MIN set point (°F)

This menu may be used to make changes to the minimum return temperature range when the Return Control mode is in use. When configuring the Custom mode in the Outdoor Reset Control mode, the return temperature changes based on the return absolute MIN temperature range.

Return Absolute MIN Temperature Range

Range	Remarks
68°F (20°C) ~ [MAX Set-point - 8°F (10°C)]	Default: 86°F (30°C)

### Setting the Automatic Make-up Water Feeder Pressure

Display	Description
	AWS pressure operation

This menu may be used to allow the boiler to maintain the space heating system water pressure to ensure that a sufficient amount of water is in the system. When the system pressure falls  $\square$ PS below the set value, the boiler opens the makeup water feeding valve for a maximum of  $\square$ minutes until the system is filled and water pressure exceeds the set value. After filling the system, the boiler runs the circulation pump for  $\square$ seconds in the space heating mode before completing the process. The makeup water feeding valve operates only when there is no space heating or DHW demand.

- ☐ Default:  $\square$ PS
- ☐ Setting Range:  $\square$ 30 PS

### Setting the Initial Start-up Number



Display	Description
	Initial start-up number

This menu may be used to set the number of water heaters initially activated during DHW stand-by periods.

- ☐ Default: 0 (Auto setting : Total Installation Number /  $\square$ Max value 3)
- ☐ Setting Range: 0- $\square$ 6

### Setting the Cascade Protocol

- ☐ Default: NPE

Display	Description
	All the slave units are NPE water heaters.
	Slave units consist of NR/NP water heaters, or a combination of NPE and NR/NP water heaters.

This menu may be used to set the communication protocol for the cascade system. Set the parameter values according to the type of slave units installed in the cascade system.

### Setting the Zone Controller Communication

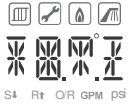
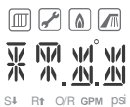
Display	Description
	SmartZone/Ready-link connection is enabled (On)
	T/T zone controller connection is disabled (Off)

This menu may be used to allow the boiler to work with a Navien SmartZone+ controller connected via a Ready-Link cable.

- ☐ Default: Off

### Setting the Minimum Heat Capacity for Space Heating

Display	Description
	Space heating minimum heat capacity (%)

This menu is used to configure the desired space heating capacity. When the boiler operates in Normal mode, the space heating capacity is limited to the set value (%).

- ☐ Default: Minimum space heating capacity of the unit (%)
- ☐ Setting range: Minimum space heating capacity- $\square$ 0%

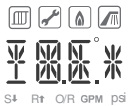

### Setting the Minimum Heat Capacity for DHW

Display	Description
	DHW minimum heat capacity (%)

This menu is used to configure the desired DHW capacity. When the boiler operates in Normal mode, the DHW capacity is limited to the set value (%).

- ☐ Default: Minimum DHW heat capacity of the unit (%)
- ☐ Setting range: Minimum DHW heat capacity- $\square$ 0%



### Setting the Navi-Link Connection

Display	Description
	Navi-Link connection is enabled( On)
	Navi-Link connection is disabled (Off)

This menu may be used to control and monitor the boiler using a Wi-Fi network via Navi-Link connection.

☑ Default: Off

### Resetting All Parameters

Display	Description
	Do not reset parameters (No)
	Reset all parameters (Yes)

This menu may be used to reset all the parameters to their factory default settings.

To reset all parameters:

1. Press the [+] or [-] buttons to change the display to [Yes].

2. Press the [Mode] button.

3. When [No] appears on the display again, all parameters have been reset.

### Setting a New Password

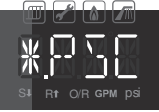
Display	Description
	Change password

This menu may be used to set a new password to access the parameter setting menu.

To set a new password:

1. Move to [\*PSC] and press the [Mode] button. The current password is displayed, with the first digit flashing.

2. Press the [+] or [-] buttons to change numbers.

3. Press the [Diagnostic] button to change places.

4. When you are done setting the password, press the [Mode] button to save it. The new password is displayed on the front panel for 3 seconds, before the boiler returns to the parameter setting mode.

#### Note

If you do not press the [Mode] button in 10 seconds after setting a new password, the new password is automatically saved and [\*PSC] is displayed on the front panel.

## 10.6 Resetting the Boiler

If an error message appears, you can try resetting the boiler to resolve the problem. To reset the boiler, press the Reset button.

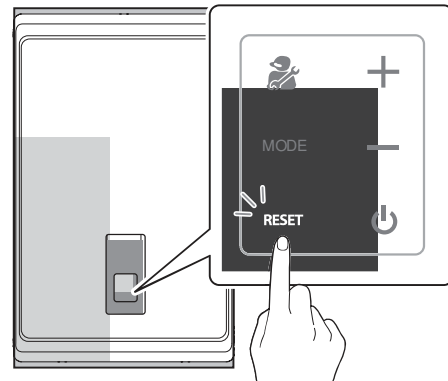

If resetting the boiler does not solve the problem, refer to the Troubleshooting section of this manual or contact Technical Support at 800-541-8791.

# 11. Appendixes

## 11.1 Gas Conversion

This boiler is configured for Natural Gas from the factory. If conversion to Propane Gas is required, the conversion kit supplied with the boiler must be used.





### WARNING

This conversion kit shall be installed by a qualified service agency\* in accordance with Navien's instructions and all applicable codes and requirements of the authority having jurisdiction. The information in these instructions must be followed to minimize the risk of fire or explosion or to prevent property damage, personal injury or death. The qualified service agency is responsible for the proper installation of this kit. The installation is not proper and complete until the operation of the converted appliance is checked as specified in the manufacturer's instructions supplied with the kit.

\* A qualified service agency is any individual, firm, corporation or company which either in person or through a representative is engaged in and is responsible for the connection, utilization, repair or servicing of gas utilization equipment or accessories; who is experienced in such work, familiar with all precautions required, and has complied with all of the requirements of the authority having jurisdiction.

In Canada: The conversion shall be carried out in accordance with the requirements of the provincial authorities having jurisdiction and in accordance with the requirements of the CAN-B-110 and CAN-B-116 Installation Code.

### Tools Required:

-  Phillips Screwdriver
-  Flathead Screwdriver
-  5/32 in or 16mm Allen Wrench
-  Combustion Analyzer or Dual Port Manometer
-  Gas Leak Detector

### Included Items:



-  Gas Orifice (refer to below table)

Model	NG		LP	
	1 STAGE	2 STAGE	1 STAGE	2 STAGE
NCB-150E	Ø5.10	Ø5.80	Ø3.10	Ø3.50
NCB-180E	Ø5.80	Ø5.95	Ø3.80	Ø3.70
NCB-240E	Ø6.10	Ø6.30	Ø3.50	Ø3.80
NCB-300E	Ø6.10	Ø6.30	Ø3.50	Ø3.80

Table 11-1 Orifice Size

-  Gas Pressure and Conversion Kit Number Labels

### Procedure:

-  Turn off both gas and water supply to the boiler.
-  Undeasp the 3 buckles that fix the cover to the boiler, and then remove the cover by lifting it and pulling it outward. See Figure 11-1 for illustration of the front cover on the unit.

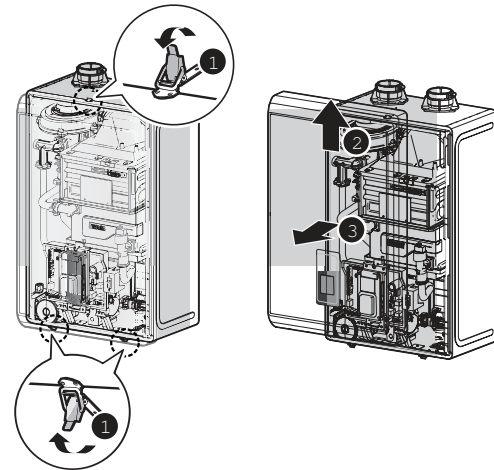



Figure 11-1 NCB-E Series Front cover

3. Once the front cover is removed, place it in a safe location to prevent accidental damage.

-  Label all the wires on the PCB.

5. Disconnect all the wires.



6. Loosen the three screws indicated in the figure.

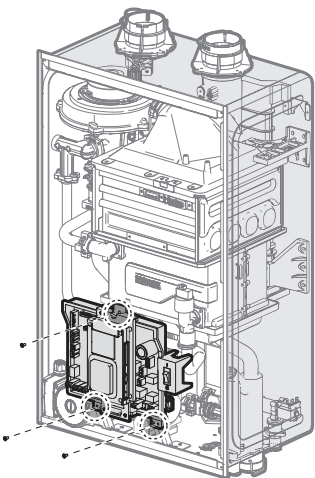

7. Remove the PCB assembly.

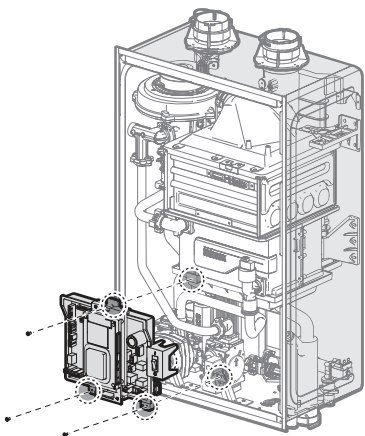

8. With the internal components exposed, locate the gas inlet pipe and the gas valve in the middle of the unit, as shown in Figure 3.

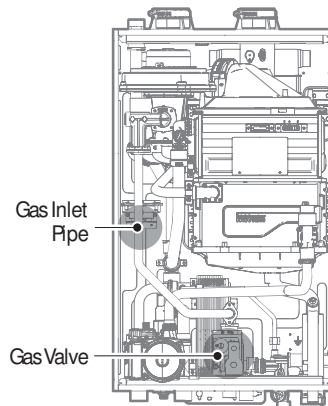

Figure 3. NCB-E Series Internal Components

9. Use a Phillips screwdriver to remove the two screws at location A - the connection below the gas valve where it connects to the pipe. See Figure 3 for reference. Once the screws are removed, carefully separate the pipe from the gas valve.

10. Once the gas inlet pipe is detached from the gas valve, find location B - the connection above the gas valve where it is attached to the fan motor assembly. Carefully remove the four screws by hand using a Phillips screwdriver and pull the gas valve away from the fan assembly to access the gas orifice.

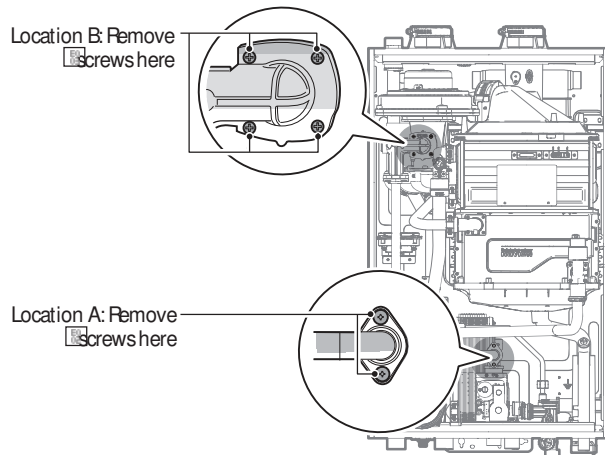

Figure 3. Detaching Gas Valve from Gas Inlet Pipe and Fan Motor Assembly

Once the Gas Orifice is exposed, remove the two screws that hold the part in place. Remove the Gas Orifice from its housing and prepare the new Gas Orifice for the LP conversion for installation.

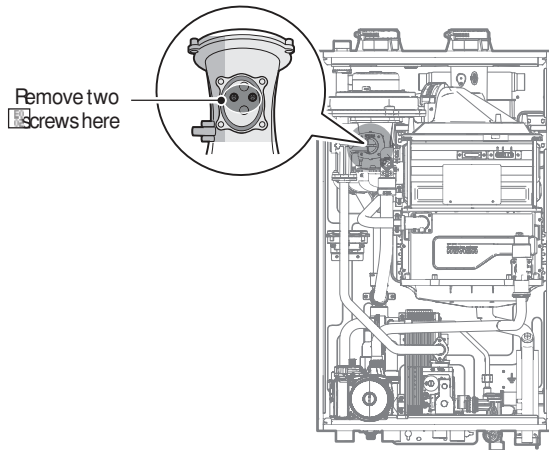

Figure 4. Access to Gas Orifice in Fan Assembly

**WARNING**

- DO NOT adjust or attempt to measure gas valve outlet pressure. The gas valve is factory-set for the correct outlet pressure. This setting is suitable for natural gas and propane, requiring no field adjustment.
- Attempting to alter or measure the gas valve outlet pressure could result in damage to the valve, causing potential severe personal injury, death or substantial property damage. Navien NCB-E boilers are shipped ready to fire natural gas ONLY.

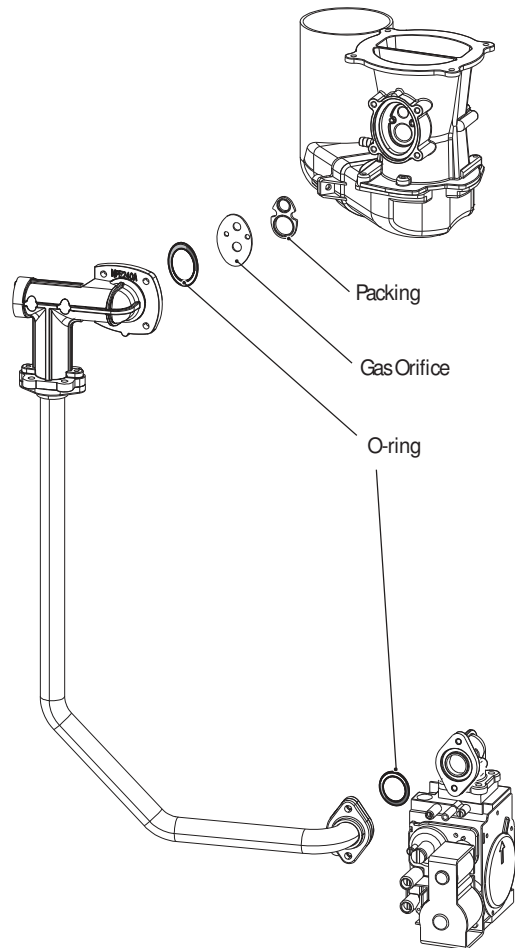

Figure 5. Exploded View of Gas Pipe Assembly

**DANGER**

See Figure 5. Inspect the O-ring between the gas valve and gas valve inlet adapter whenever they are disassembled. The O-ring must be in good condition and must be installed. Failure to comply will cause a gas leak, resulting in severe personal injury or death.

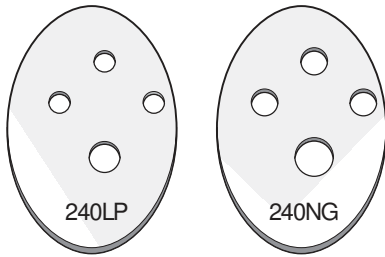
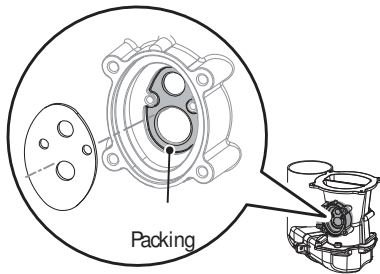

Figure 6. Orifice Identification

14. Remove the Gas Orifice, ensure that the packing is properly seated inside the port, and then install the new Gas Orifice for use with LP gas. Ensure that the Orifice is properly seated on the packing inside the port before proceeding to the next step.



15. Replace the gas inlet pipe to its original position and use all screws to secure all connections.

**Note** Do not overtighten as this may damage or crack the components.

**! DANGER**

Inspect the O-ring between the gas valve and gas valve inlet adapter whenever they are disassembled. The O-ring must be in good condition and must be installed. Failure to comply will cause a gas leak, resulting in severe personal injury or death.

16. Place the PCB assembly back on to the boiler and tighten the three screws.

17. Check the labels carefully and then connect all the wires.

18. Set the front panel Dip Switch to change the gas type. For LP, set Dip Switch 1 to On. For NG, set DIP SW 1 to Off.

**! WARNING**

Ensure that you have turned off the power to the boiler before accessing the DIP switches.

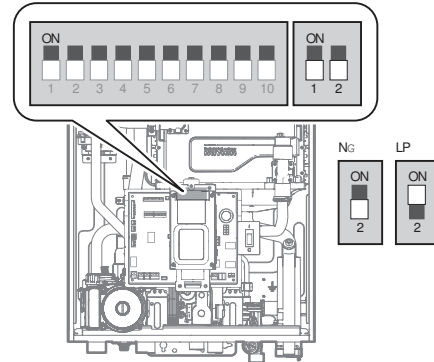

**! DANGER**

19. When conversion is required, be sure to set the front panel DIP switches according to the supply gas type.
20. Failure to properly set the DIP switches could cause carbon monoxide poisoning, resulting in severe personal injury or death.

21. Turn on the gas and water supply to the boiler.

8. Measure and adjust the gas/air ratio.
- Option 1 Using Combustion Analyzer (recommended)
- Loosen the screw, rotate the plate and remove the gasket to access the emissions monitoring port as shown in Figure 7.
  - Insert the analyzer into the port (Figure 7).

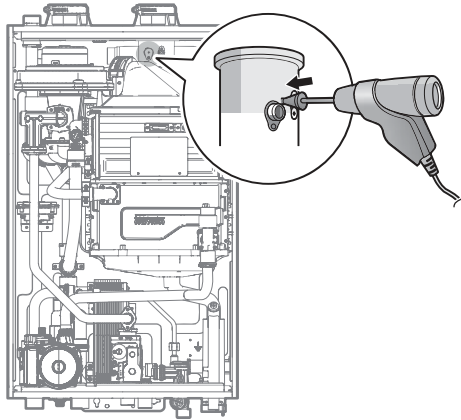

Figure 7. Insert the Analyzer

Model	Fuel	High fire	Low fire
		%CO <sub>2</sub>	%CO <sub>2</sub>
NCB-50E	NG	8.9	9.5
	LP	9.0	9.8
NCB-80E	NG	8.9	9.5
	LP	9.0	9.8
NCB-100E	NG	8.9	9.5
	LP	9.0	9.8
NCB-140E	NG	8.9	9.5
	LP	9.0	9.8

Table 1 CO<sub>2</sub> value  
(CO<sub>2</sub> values must be within 0.5% of the values listed.)

- Fully open several hot water fixtures and set the boiler to operate at Stage MIN mode.

**Note** For operation mode selection, refer to “Setting the Operation Mode” on page 56.

Measure the CO<sub>2</sub> value at low fire.

If the CO<sub>2</sub> value is not within 0.5% of the value listed in Table 1 the gas valve set screw will need to be adjusted. If adjustment is necessary, locate the set screw as shown in Figure 8. Using a 5/32 in or 4 mm Allen wrench, turn the set screw no more than 7 turns clockwise to raise or counterclockwise to lower the CO<sub>2</sub> value.

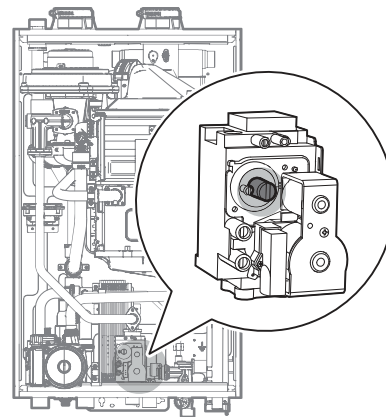

Figure 8. Set Screw Location

**Note** The set screw is located behind the screw-on cover. This must be removed first.

- Fully open several hot water fixtures and set the boiler to operate at Stage D. MAX mode (refer to “Setting the Operation Mode” on page 56). Measure the CO<sub>2</sub> value at high fire. If the CO<sub>2</sub> values do not match Table 1 at high fire, do not adjust the gas valve. Check for the proper Gas Orifice.

**! DANGER**

Improper gas valve settings can cause severe personal injury, death or substantial property damage.

Option **1** Using Digital Manometer

- a. Open the offset pressure port by loosening the screw two turns as shown in Figure 9.

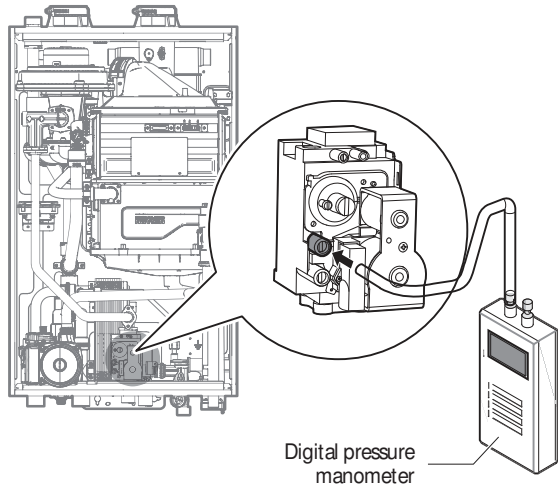

Figure 9. Connect Digital Pressure Monometer

- b. Connect a manometer to the offset pressure port. For dual port manometers, use the positive pressure side.

Model	Kit Part No.	Gas Type	Offset
NCB-50E	NAC-N5	NG	-0.0 in ±0.0 in
	NAC-L5	LP	-0.03 in ±0.0 in
NCB-80E	NAC-00	NG	-0.0 in ±0.0 in
	NAC-01	LP	-0.03 in ±0.0 in
NCB-100E	NAC-500	NG	-0.0 in ±0.0 in
	NAC-05	LP	-0.0 in ±0.0 in
NCB-100E	NAC-600	NG	-0.0 in ±0.0 in
	NAC-06	LP	-0.0 in ±0.0 in

Table 3. Offset value for low fire

- c. Fully open a hot water fixture and set the boiler to operate at **1** stage MIN mode (refer to table **1**). Measure the offset value at low fire and compare it to the values in Table 3. If the offset value is out of range, the gas valve set screw will need to be adjusted.

If adjustment is necessary, locate the set screw as shown in Figure **10**. Using a  $\frac{5}{32}$  in or 4 mm Allen wrench, turn the set screw no more than  $\frac{1}{4}$  turn clockwise to raise or counterclockwise to lower the offset value.

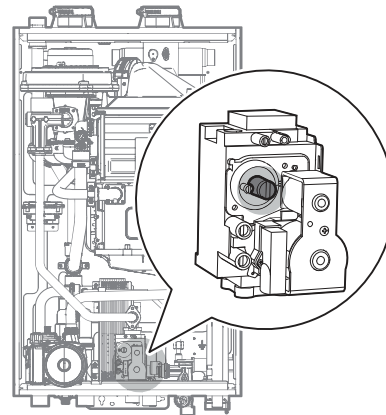

Figure 10. Set Screw Location

**Note**

The set screw is located behind the screw-on cover. This must be removed first.

- d. At high fire, do not check the offset value and never adjust the gas valve.

**! DANGER**

Improper gas valve settings can cause severe personal injury, death or substantial property damage.

- 10** Once the CO<sub>2</sub> or offset values have been confirmed, apply the included conversion stickers to show that the appliance has been converted to propane gas. Place these labels adjacent to the rating plate as shown in Figure **11**.

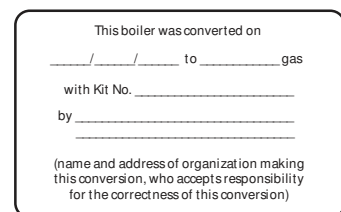
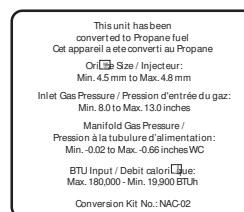
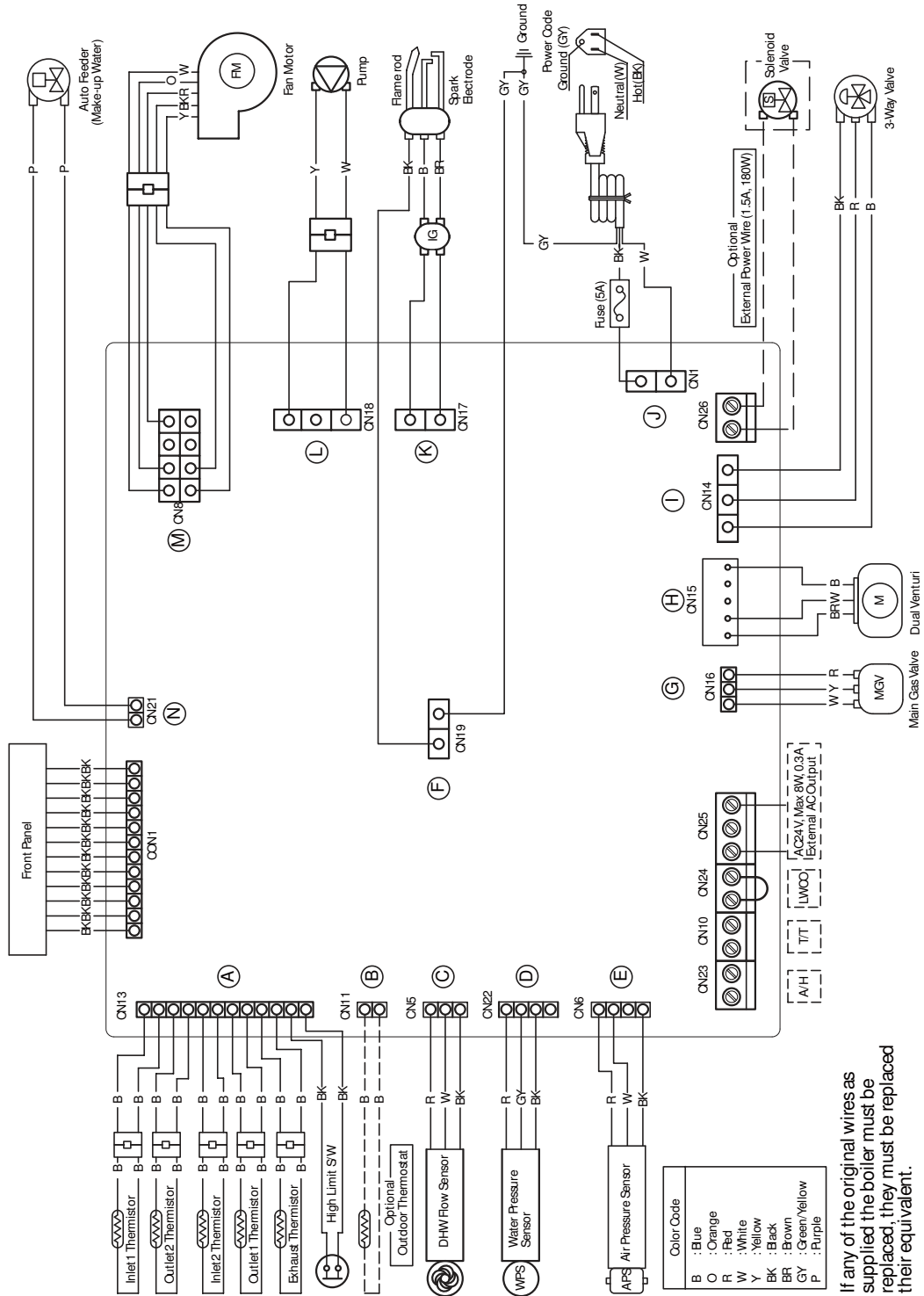
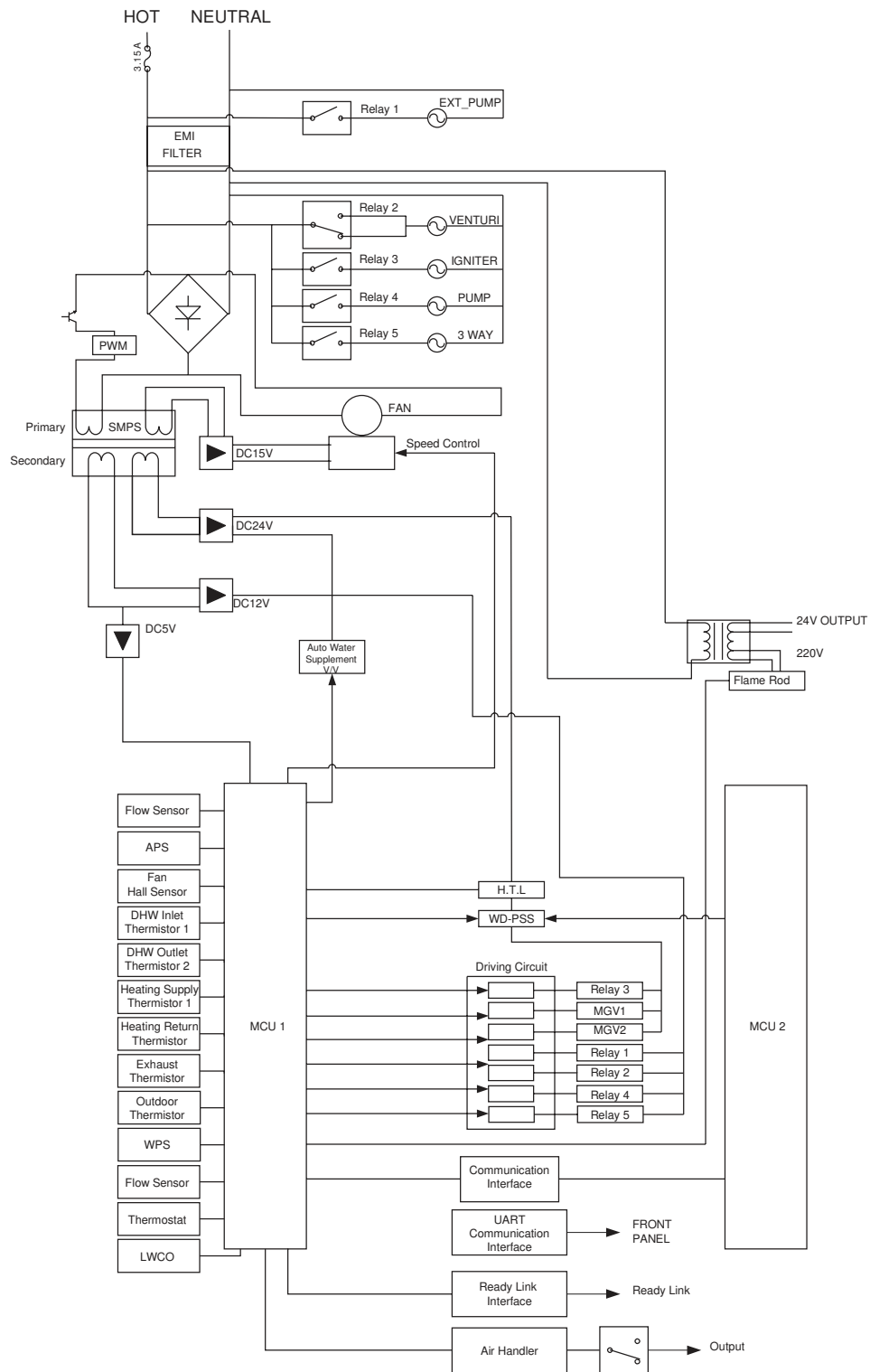

Figure 11. Proper Placement of Gas Conversion Labels

## 11.2 Wiring Diagram



### 11.3 Ladder Diagram



# 11.4 Component Assembly Diagrams and Parts Lists

## 11.4.1 Case Assembly

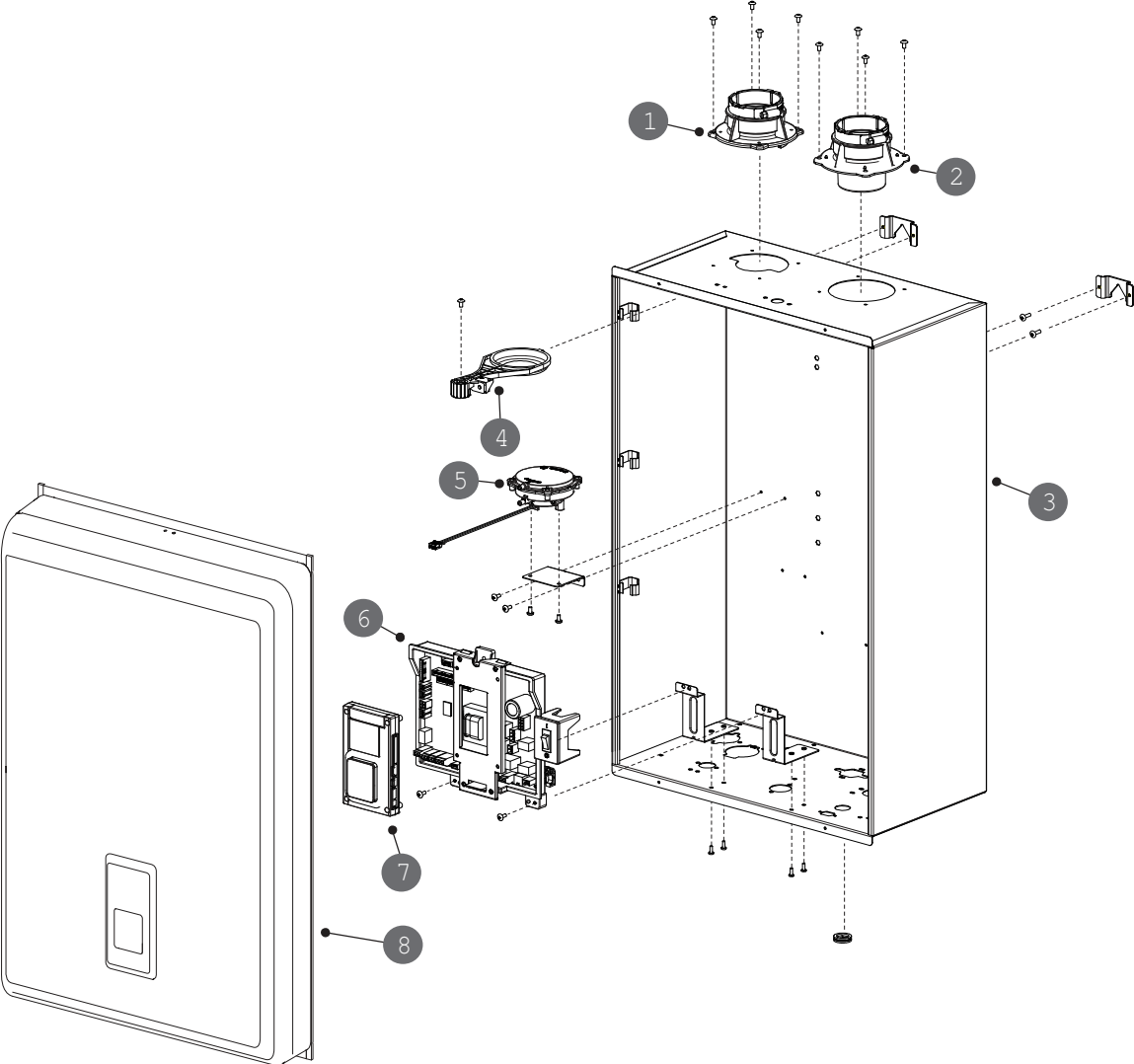



#	Description	Part #	Remark
1	Intake Air Duct Assembly	30008661B	
2	Exhaust Pipe Assembly	30008673A	
3	Case	10033178A	
4	Intake Air Filter	10007668A	
5	Air Pressure Sensor	30010316A	
6	PCB	30011161A	
7	Front Panel	30011169A	
8	Cover	30011176B	



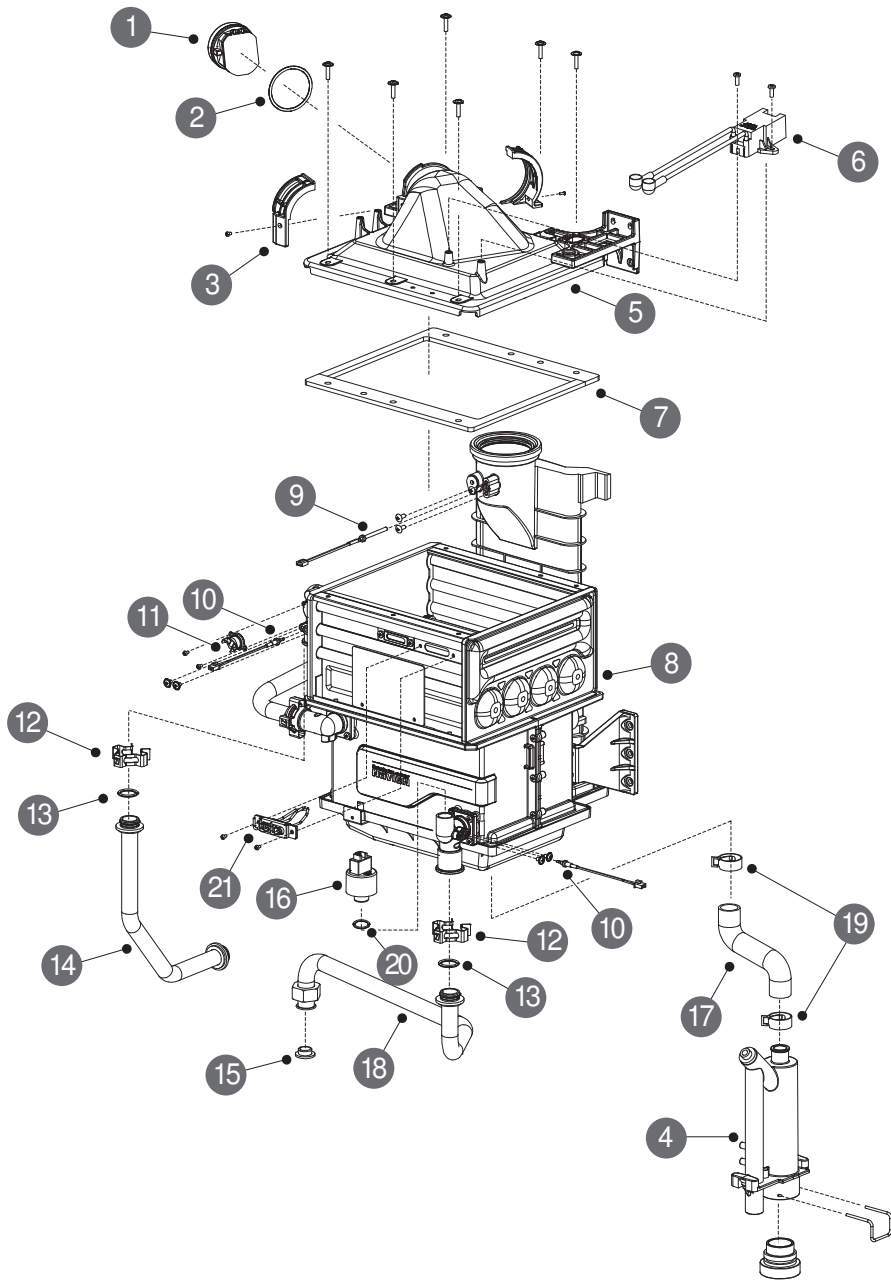



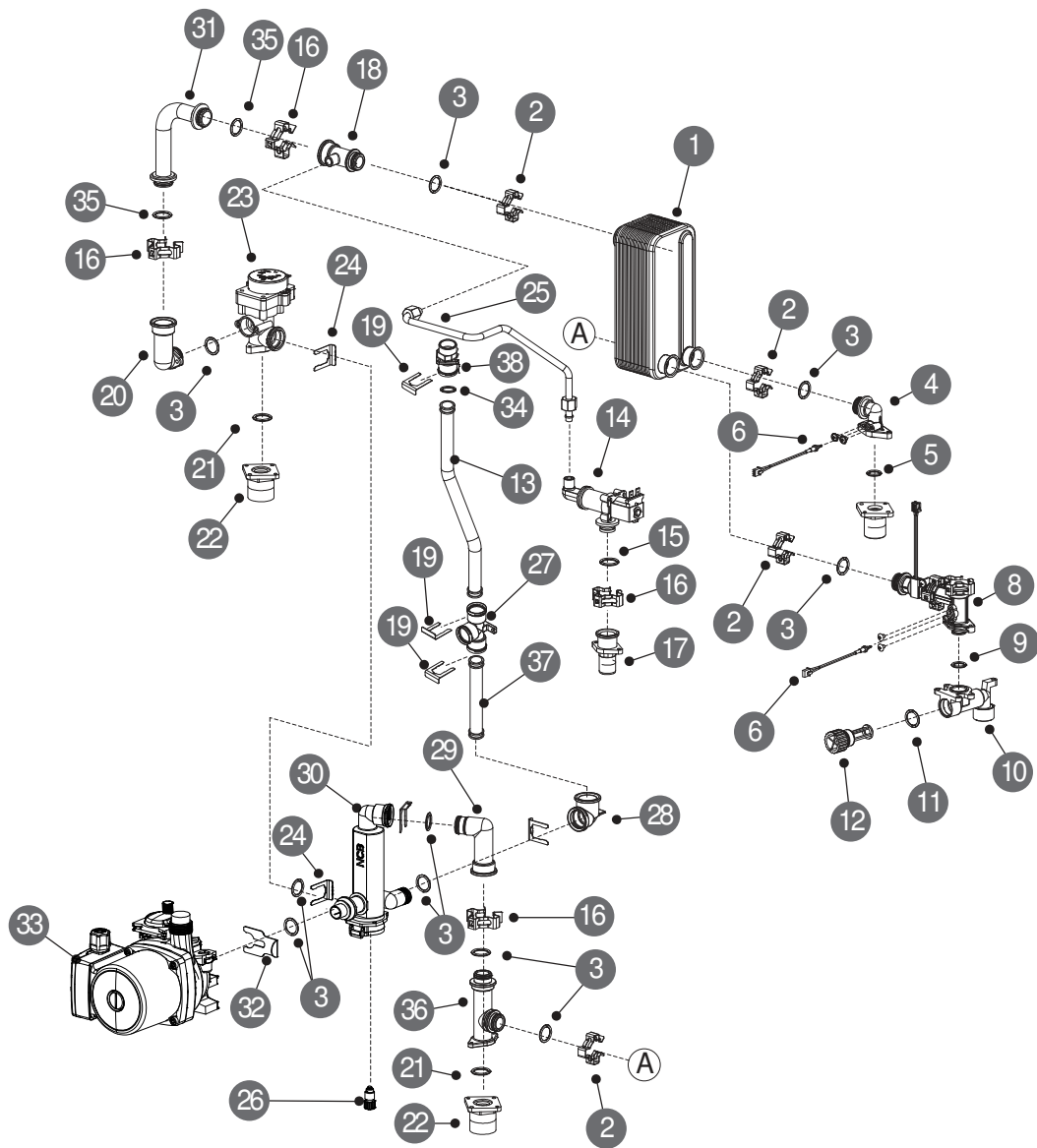

## 11.4.2 Burner Assembly



#	Description	Part #	Remark
1	Damper	30008815A	
2	O-Ring (G50)	30003019A	
3	Fan Bracket	30001095A	
4	Sphon	30001180A	
5	Burner Chamber Ass'y	30030183A	NCB-150E
		30000353A	NCB-180E
		30008110A	NCB-110E/150E
6	Ignition Transformer	30001055A	
7	Burner Packing	30007105A	NCB-150E
		30001677A	NCB-180E
		30001671A	NCB-110E/150E
8	Heat Exchanger Ass'y	30001697A	NCB-150E
		30001811A	NCB-180E
		30001811A	NCB-110E
		30001817A	NCB-110E
9	Thermistor (Exhaust)	30009178A	
10	Thermistor (Water)	30008366A	
11	High Limit Switch	30001558A	
12	Fastener	30007859A	
13	O-Ring (P19)	30001711A	
14	Heat Exchanger Outlet Pipe	30001733A	NCB-150E
		30001913A	NCB-180E
		30001911A	NCB-110E/150E
15	Packing (Circulation Pump)	300017617A	
16	LWCO (Pressure Sensor)	30007911A	
17	Sphon Hose	300017671A	
18	Return Pipe	30001819A	NCB-150E
		30001903B	NCB-180E
		30001917B	NCB-110E/150E
19	Sphon Fastener	30007833A	
20	LWCO Packing	30006873A	
21	Ignitor	30001816A	NCB-180E/110E/150E
		30001833A	NCB-150E

### 11.4.3 Waterway Assembly



#	Description	Part #	Remark
 DHW Heat Exchanger	300558 	NCB-150E	
	300081 	NCB-180E	
	300050 	NCB-100E / 130E	
 Fastener	10007858A		
3	O-Ring (PUB)	1000695 	
 DHW Outlet Elbow	3001131 		
5	Packing	1000685 	

#	Description	Part #	Remark
6	Thermistor	30008366A	
7	DHW Outlet Adaptor	30003717A	
8	DHW Flow Sensor	3001033A	
9	O-Ring (P11)	10006951A	
10	DHW Cold Water Adaptor	30015581A	NCB-150E
		30010315A	NCB-160E
		30010316A	NCB-170E
		30010317A	NCB-180E
11	O-Ring (P10)	10017111A	
12	DHW Cold Water Filter	30007878A	
13	Vent Pipe	30011737A	
14	Auto Fill Valve	30011111A	
15	O-Ring (P16)	10017110A	
16	Fastener	10007859A	
17	Auto Fill Valve Adaptor	-	
18	3-Way Outlet Adaptor B	30011331A	
19	Fastener	10017716A	
20	3-Way Outlet Adaptor A	30011331A	
21	Packing	10011380A	
22	Connection Adaptor	10011308A	
23	3-Way Valve	30001331B	
24	Fastener	10007733A	
25	Water Fill Pipe	30011327A	
26	Drain Cock	30008630B	
27	Space Heating Supply Pipe	30011905A	
28	Space Heating Supply Adaptor B	100116930A	
29	Space Heating Return Adapter A	30011319A	
30	Space Heating Strainer	30011516A	
31	3-Way Outlet Pipe	30011006A	
32	Circulation Pump Fastener	10031531A	
33	Circulation Pump	300116307A	
34	O-Ring (Φ117x3.5t)	10033699A	
35	O-Ring (Φ118x1.8t)	10003011A	
36	Space Heating Return Adapter B	30011330A	
37	SH Supply Pipe	30011736A	
38	Vent Adaptor	10033691A	

### 11.4.4 Fan (Gas) Assembly

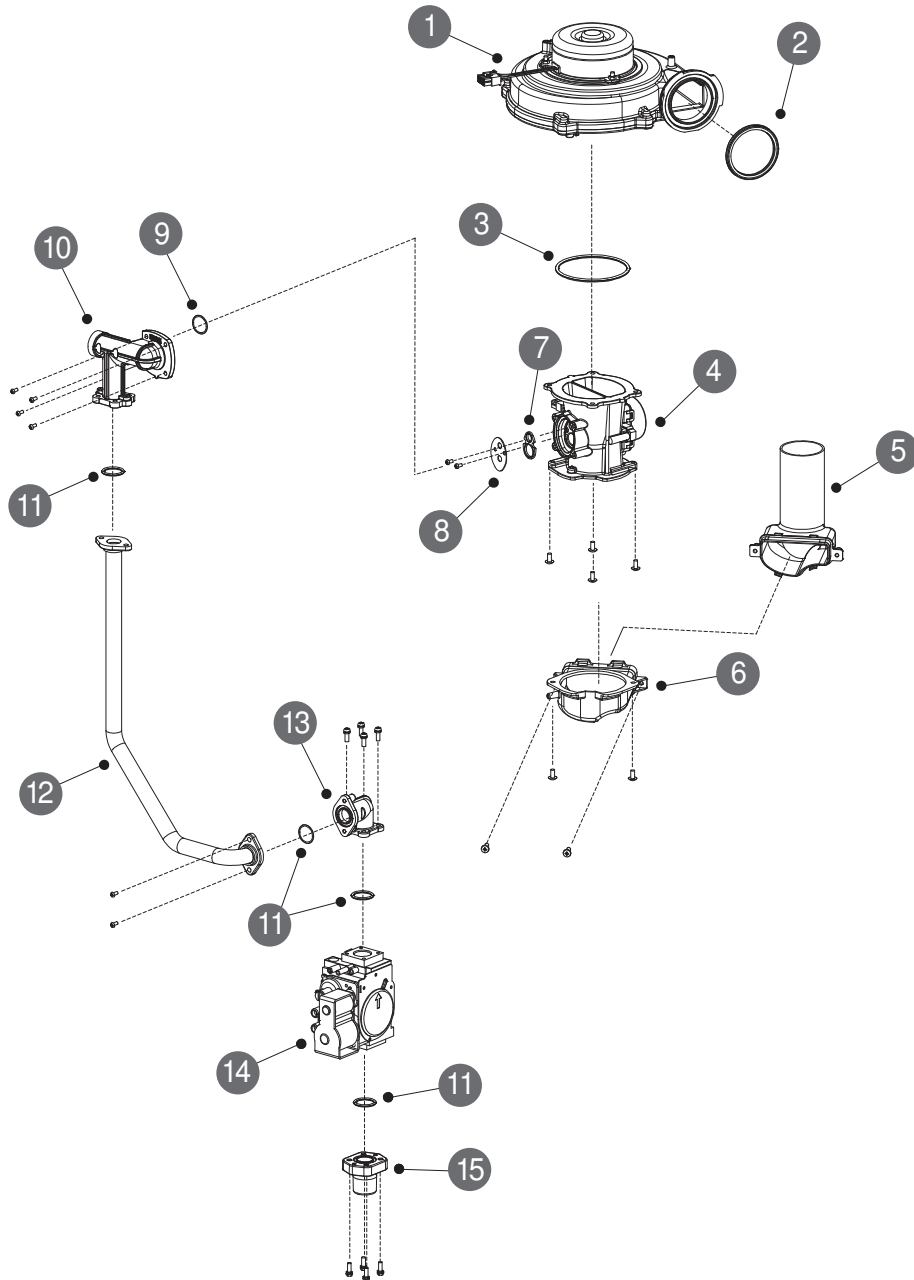

#	Description	Part #	Remark
1	Fan Assembly	3005586A	NCB-180E/190E/110E
2	Fan Packing	10011711A	
3	O-Ring (G75)	10018079A	
4	Dual Venturi	3005587A	NCB-150E
		30010671A	NCB-180E
		30008909A	NCB-110E/115E
5	Slence	10030061A	NCB-150E
		10019111A	NCB-180E
		10013819A	NCB-110E/115E
6	Slence Adaptor	10033736A	NCB-150E
		10013861A	NCB-180E
		10019111A	NCB-110E/115E
7	Venturi Packing	10011660A	NCB-180E
8	Gas Orifice	10033737A	NCB-150E
		10011159A	NCB-180E (NG)
		10019111B	NCB-110E/115E (NG)
		10031176A	NCB-150E (LP)
		10011110A	NCB-180E (LP)
		100111189A	NCB-110E/115E (LP)
9	O-Ring (P31)	10019090A	
10	Gas Adapter	30008131A	
11	O-Ring (P10)	10006931A	
12	Gas Pipe	30011311A	NCB-150E
		30011388A	NCB-180E
		30011058A	NCB-110E/115E
13	Gas Connector	10017119A	
14	Gas Valve	30011586A	NCB-180E
		30008119A	NCB-150E/110E/115E
15	Gas Inlet Adaptor	10017118A	

## 11.5 Outdoor Temperature Sensor (Optional)

### Outdoor Temperature Sensor Installation

1. Pull out the sensor body from the cap.
2. Attach the body to the wall using the screws/anchors provided with the device.
3. Run the wires into the device body through the grommet opening.
4. Connect the wires to the terminal block.
5. Attach the cap to the body.

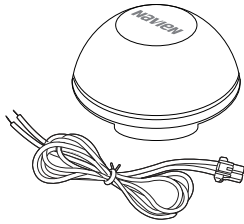

Navien Outdoor Temperature Sensor Kit

### Outdoor Temperature Sensor Installation Guidelines

- ❑ Avoid areas with temperature fluctuations by direct sunlight, and where the temperature may not be representative of true outdoor temperature.
- ❑ Best location to install the temperature sensor is on a North or Northeast side of a structure under eaves where the sensor is shielded from direct sunlight.
- ❑ Avoid placing sensor in close proximity of heat sources that may affect correct temperature sensing. (fans, exhausts, vents, lights)
- ❑ Avoid installing the sensor in areas where the sensor is subjected to excessive moisture.
- ❑ Use 18-gauge wiring (thermostat wiring) with no splices. (except at the unit harness connection with yellow leader wire.)
- ❑ Caution should be taken to avoid potential electromagnetic interference (EMI) by routing separately from potential sources such as line voltage wiring. When necessary, shielded cable may be used.
- ❑ Make sure wiring connections are secure before closing the cap.
- ❑ The sensor is a water resistant device.
- ❑ Any damage to the device may require the replacement of the entire component.

## 11.6 Outdoor Reset Control (Available with Optional Outdoor Temperature Sensor)

The Outdoor Reset Control feature may be used to enhance energy efficiency while maintaining optimal heating performance. With the Outdoor Reset Control, the space heating temperature setting automatically changes according to the outdoor temperature and the current space heating system application (system load).

You can configure the Outdoor Reset Control settings on the front panel by entering the Special Parameter Setting mode. Refer to “10.5 Setting the Parameters” on page 56.

### Note

The Outdoor Reset Control feature requires installation of an outdoor temperature sensor, and it only works when the boiler is running in the normal operation mode. It does not work when the boiler is running in either the Minimum (MIN) or Maximum (MAX) mode, or when the boiler's front panel displays a fault.

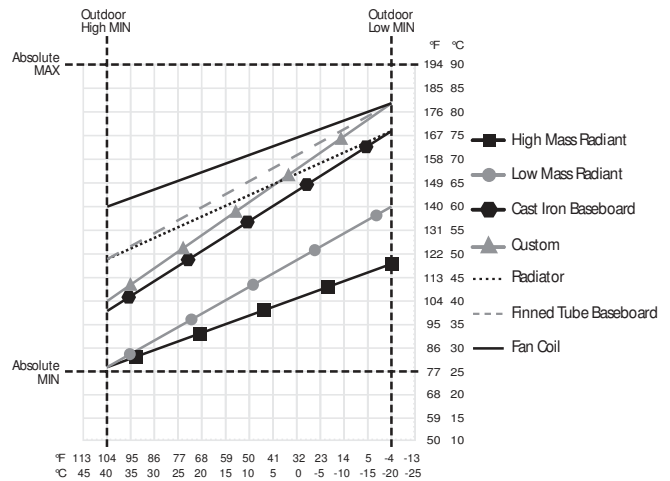

Space Heating Temperature Setting for the Outdoor Reset Control Feature

The following tables list the default space heating temperature range by system heat load and the applicable outdoor temperature ranges.



Outdoor Temperature Sensor Installation Guidelines

Heat Load	Supply Set-point Range	Return Set-point Range
Finned Tube Baseboard (default)	80-80°F (6.5-8.5°C)	60-63.5°F (38-63.5°C)
Fan Coil	80-80°F (60-8.5°C)	66-67°F (6.5-63.5°C)
Cast Iron Baseboard	60-70°F (37.5-76.5°C)	86-89°F (30-59°C)
Low Mass Radiant	80-80°F (6.5-60°C)	70-66°F (16.5-6.5°C)
High Mass Radiant	80-80°F (6.5-6.5°C)	70-60°F (16.5-38°C)
Radiators	80-70°F (6.5-76.5°C)	60-59°F (38-59°C)
Custom	Supply Control (Absolute MIN/ MAX set point)	Return Control (Absolute MIN/ MAX set point)

Outdoor Temperature Range and Default Temperature Settings

Set Point	Range	Remarks
Outdoor Low Temperature	-4 to 59°F (-10 to 5°C)	Default: 4°F (-10°C)
Outdoor High Temperature	Outdoor Low Temperature Set Point + 4°F (5°C) to 6°F (10°C)	Default: 70°F (16°C)

# Memo

---

# Installation & Operation Manual

## NCB-E Condensing Combi-Boilers

### Getting Service

If your boiler requires service, you have several options for getting service:

- ☐ Contact Technical Support at 800-591-8791 or on the website: [www.navien.com](http://www.navien.com).
- ☐ For warranty service, always contact Technical Support first.
- ☐ Contact the technician or professional who installed your boiler.
- ☐ Contact a licensed professional for the affected system (for example, a plumber or electrician).

When you contact Technical Support, please have the following information at hand:

- ☐ Model number
- ☐ Serial number
- ☐ Date purchased
- ☐ Installation location and type
- ☐ Error code, if any appears on the front panel display

Version : 5.17 (Feb. 16, 2016)



Navien, Inc.  
800.591.8791 [www.Navien.com](http://www.Navien.com)  
Goodyear Irvine, CA 92618